

THE CITY OF SIOUX FALLS
AMERICAN WITH DISABILITIES ACT (ADA) TRANSITION PLAN

BLANCK GROUP LLC

AUTHORS

Peter Blanck, Ph.D., J.D.

&

James G. Felakos, J.D.

Syracuse, New York, USA

© THE BLANCK GROUP, LLC, 2021

See Appendix 19 for Author Short Bios

Contents

Contents.....	ii
Table of Authorities (Primary Sources).....	viii
Acknowledgments.....	1
Executive Summary.....	3
Chapter 1 Overview	1-1
I. Introduction	1-1
II. Federal Disability Law	1-3
A. Federal Requirements.....	1-3
B. Federal Enforcement	1-12
III. Guiding Principles	1-15
A. Universal Design.....	1-16
IV. Review Approach	1-17
A. Method	1-17
V. Sioux Falls Area	1-20
A. Population, Geography, Economy & Climate.....	1-20
B. Climate Considerations	1-20
C. Governance	1-21
D. Prior Transition Plans and Self-Evaluations	1-22
Chapter 2 - Transportation	2-1
I. Introduction	2-1
A. Universal Design.....	2-3
II. Federal Disability Law Regarding Transportation	2-3
A. Federal Requirements.....	2-3
B. Federal Enforcement	2-8

III.	Review Approach	2-10
A.	Method	2-10
B.	Informational Sources and Meetings.....	2-10
IV.	Sioux Falls Area Transportation Overview	2-11
A.	Transportation Governance.....	2-12
B.	Fixed Route Buses	2-14
C.	Paratransit.....	2-17
V.	Potential Challenges to the Current System and Recommendations.....	2-18
A.	Financial issues.....	2-19
B.	Snow.....	2-25
C.	Inaccessible bus stops and sidewalks	2-27
D.	Maintenance issues.....	2-30
E.	Signage	2-32
F.	Training and Procedure.....	2-32
G.	Governance	2-34
H.	Technology.....	2-34
Chapter 3 – Sidewalks & Public Rights of Way		3-1
I.	Federal Requirements.....	3-1
II.	Sioux Falls Sidewalks	3-9
A.	Sidewalks and Curb Ramps	3-10
B.	Sidewalk Maintenance & Snow Removal.....	3-17
C.	On-Street Parking.....	3-21
Chapter 4 – Parks and Recreation.....		4-1
I.	Federal Requirements.....	4-1
II.	Sioux Falls Compliance	4-4

A.	Neighborhood Parks	4-4
B.	Pools.....	4-6
C.	Golf.....	4-6
D.	Great Plains Zoo	4-6
E.	Great Bear Recreation Park	4-7
F.	Family Park.....	4-7
G.	Great Bear Archery Range.....	4-7
H.	Bike Trail System	4-8
I.	Parks and Recreation Policies	4-8
J.	<i>Recommendations</i>	4-9
Chapter 5 –	Administrative Requirements and ADA Coordinator	5-1
I.	Federal Requirements.....	5-1
II.	Sioux Falls Compliance.....	5-3
Chapter 6 –	Effective Communications & Technology	6-1
I.	Federal Requirements.....	6-1
II.	Sioux Falls Compliance.....	6-6
III.	<i>Recommendations</i>	6-9
Chapter 7 –	Employment and Human Relations Department	7-1
I.	Federal Requirements.....	7-1
II.	Sioux Falls Compliance.....	7-4
III.	<i>Recommendations</i>	7-7
Chapter 8 –	Emergency Management	8-1
I.	Federal Requirements.....	8-1
II.	Sioux Falls Compliance.....	8-7
A.	Planning.....	8-7

B.	Testing of Preparedness.....	8-10
C.	Notification	8-11
D.	Community Evacuation and Transportation	8-12
E.	Emergency Shelter Programs.....	8-12
F.	Emergency Medical Care and Services	8-13
G.	Access to Other Issues	8-13
H.	Sioux Falls COVID-19 Response.....	8-14
Chapter 9 –	Police Procedures.....	9-1
I.	Federal Requirements.....	9-1
II.	Sioux Falls Compliance.....	9-8
A.	Mental Health	9-8
B.	Modifications to Policies.....	9-12
C.	Communications	9-12
III.	<i>Recommendations</i>	9-13
Chapter 10 –	Other City Buildings and Programs	10-1
I.	Sioux Falls Arena (old arena).....	10-1
II.	Denny Sanford Premier Center and Convention Center.....	10-1
III.	Washington Pavilion	10-3
IV.	Sioux Falls Stadium.....	10-4
Chapter 11 –	Libraries.....	11-1
I.	Federal Requirements.....	11-1
II.	Sioux Falls Compliance.....	11-5
III.	<i>Recommendations</i>	11-7
Chapter 12 –	Health Care.....	12-1
I.	Federal Requirements.....	12-1

A.	Physical Accessibility	12-3
B.	Communications/Changes to Practices/Policies for Patients with Auditory Disabilities	12-6
C.	HIV.....	12-9
D.	Other Programmatic Issues.....	12-10
E.	Accessibility of Electronic Health Records	12-14
II.	Sioux Falls Compliance	12-15
III.	<i>Recommendations</i>	12-17
Chapter 13 –	Voting	13-1
I.	Federal Requirements.....	13-1
II.	Federal Enforcement	13-3
III.	Sioux Falls Compliance	13-5
IV.	<i>Recommendations</i>	13-6

Appendices

- Appendix 1: Statutory and Regulatory Excerpts.
- Appendix 2: Documents Reviewed (Illustrative).
- Appendix 3: On Time Performance Data.
- Appendix 4: Monthly bus driver training minutes.
- Appendix 5: Ramps Installed – Overlays and Reconstructions.
- Appendix 6: Sioux Falls 2017 Updated Parks Department Transition Plan and Selected Documents.
- Appendix 6 (A): 2017 ADA Parks Department Transition Plan- updated 2017.pdf.
- Appendix 6 (B): ADA- 2019 project scope.pdf.
- Appendix 6 (C): ADA Accessibility Review Board Minutes- July 25- 2017.
- Appendix 6 (D): Capital Program 2019 – 2023- p. 114- ADA Transition Plan Improvements.
- Appendix 7: City of Sioux Falls Parks Department ADA Related Policies.
- Appendix 8: Sioux Falls Executive Orders and Policies Regarding Disability.
- Appendix 9: InterpreCorps, LLC, and Communication Service for the Deaf Contracts
- Appendix 10: 211 Help Line Contract.
- Appendix 11: Sample Web Accessibility Report.
- Appendix 12: Emergency Preparedness Efforts for those with Disabilities.
- Appendix 13: Emergency Planning Maps Regarding Disability.
- Appendix 14: Emergency Planning: Region 3 At Risk Populations: Community-Based Organizations.
- Appendix 15: Sioux Falls Animal Emergency Response Plan.
- Appendix 16: Sioux Falls Police Department Policies Regarding Disability.
- Appendix 17: Documents related to Crisis Intervention Teams
- Appendix 18: Sioux Falls Health Department—Falls Community Health Standard Operating Policy/Procedure for ADA: Providing Care to Individuals with Disabilities.
- Appendix 19: Author Bios, About the Blanck Group, LLC.

Table of Authorities (Primary Sources)

Cases

American Ass'n of People with Disabilities v. Holland (AAPD. v. Holland), 647 F.3d 1093 (11th Cir. 2011).
 13-4

Barden v. City of Sacramento, 292 F.3d 1073 (9th Cir. 2002), *cert. denied*, 539 U.S. 958 (2003)3-1, 3-5

Barrier-Free Health Care Initiative, U.S. Dept. of Justice, Civil Rights Division 12-2

Board of Trustees of the University of Alabama v. Garrett, 531 U.S. 356 (2001) 7-1

Bragdon v. Abbott, et al., 524 U.S. 624 (1998) 12-9

Brief for the United States of America as Amicus Curiae in Support of Affirmance, *Disabled in Action and United Spinal Assn. v. Board of Elect. in the City of New York and Frederic M. Umame*, 2nd Cir., Civ. 12-4412 at p. 14-15. Filed Aug. 14, 2013. (“DOJ DIA v. New York City Brief.”)13-1, 13-2

Brooklyn Center for Independence of the Disabled (BCID), et al. v. Mayor Bloomberg, et al., No. 1:11-cv-06690-JMF, E.D. N.Y. (Nov. 7, 2013) 8-5

California Council of the Blind, et al., v. County of Alameda, p. 10-11, Civ. No. 13-cv-03443-JCS., N.D. Cal. (Oct. 24, 2013) 13-4

California Foundation for Independent Living Centers (CFILC), et al., v. City of Oakland (2010)..... 8-5

Californians for Disability Rights, Inc. (“CDR”), California Council of the Blind (“CCB”), Ben Rockwell and Dmitri Belser v. California Department of Transportation (“Caltrans”) and Will Kempton, No. C-06-5125 SBA (N.D. CA., dated Dec. 21, 2009). 1-14

Communities Actively Living Independently and Free (CALIF), et al. v. City of Los Angeles, No. 2:09-cv-00287-CBM –RZ, C.D. Ca. (Feb. 10, 2011) 8-4

Crawford, et al., & the United States v. City of Jackson, Mississippi, and the City of Jackson Public Transportation System (JATTRAN), No. 3:08-cv-586-TSL-FKB, March 30, 2010 2-9

Cullen v. Netflix, Inc., No. 5:11-Civ-01199 (N.D. Cal. filed Mar. 11, 2011) 6-5

DOJ Project Civil Access settlement agreement with Kansas City, Missouri, dated July 25, 2012 6-3

Feldman v. Pro Football, Inc., 419 Fed. Appx. 381, 2011 U.S. App. LEXIS 6188 (4th Cir. Mar. 25, 2011) 10-3

Fortyone v. City of Lomita, Civ. No. 12-56280 (9th Cir. 9/5/2014)..... 3-9

Frame v. City of Arlington, 657 F.3d 215 (5th Cir., *en banc*, Sept. 15, 2011) 2-7

Frame v. City of Arlington, Civ. 4:05-CV-470 (N.D. Tex. Oct. 2012) 3-2

<i>Gorman v. Barch</i> , 152 F.3d 907, 912 13 (8 th Cir. 1998).....	9-6, 9-13
<i>Hamer v. City of Trinidad</i> , 924 F.3d 1093 (9th Cir. 2019), <i>cert. denied</i> , 140 S.Ct. 644 (2019)	3-1
<i>Lewis v. Truitt</i> , 960 F.Supp 175 (D. Ind. 1997)	9-1, 9-7
<i>Myrtis Hill v. Fairfield Nursing and Rehabilitation Center LLC, et al.</i> , No. CV-06-1266, 2012 WL 5077166 (Ala. Oct. 19, 2012).....	12-6
<i>National Association of the Deaf v Netflix, Inc.</i> ,C.A. No. 11-CV-30168-MAP, 2012 U.S. Dist. LEXIS 84518 (June 19, 2012).....	6-5
<i>Reynolds v. Sims</i> , 377 U.S. 533, 562 (1964)	13-1
<i>Richard Bell, et al. v. Catfish Parlour, Inc., et al.</i> , Civ. No. A-01-CA-583-JN (U.S. Dist. Ct., W.D. Tex., Austin Div. 2002)	9-1, 9-7
<i>Saenz v. Roe</i> , 526 U.S. 489 (1999).....	2-1
Settlement Agreement between the United States and the City of Independence, Kansas, Apr. 29, 2011	13-3
Settlement Agreement between the United States and the Van Buren County, Arkansas, June 28, 2011.	13-3
Settlement Agreement between the United States of America and Barix Clinics, July 26, 2013.....	12-10
Settlement Agreement between the United States of America and Fayetteville Pain Center, January 30, 2013.	12-10
Settlement Agreement between the United States of America and Woodlawn Family Dentistry, January 30, 2013	12-10
Settlement Agreement, <i>United States v. City of Des Moines, IA, and City of City of Des Moines, IA, Public Library</i> . No. DJ 204-28-72 (Signed March 2, 2011)	1-14
Settlement Agreement, <i>United States v. City of Trinidad, CO</i> . No. DJ # 204-13-317 (signed Feb. 7, 2018) 1-14	
<i>Shapiro v. Thompson</i> , 394 U.S. 618 (1969)	2-1
<i>Sutton v. United Air Lines, Inc.</i> , 527 U.S. 471 (1999).....	1-8
<i>Toyota Motor Manufacturing, Kentucky, Inc. v. Williams</i> , 534 U.S. 184 (2002).....	1-8
U.S. DOJ settlement with Kansas City, MO (Dated July 25, 2012)	3-7
United States Department of Justice, Project Civic Access web page	1-13

<i>United States v. Guest</i> , 383 U.S. 745 (1966)	2-1
<i>United States v. Maine</i> , Civ. No. 06-86-B-W (D. Me. 2006)	13-4
<i>United States v. The City of Hudson</i> , New York, Oct. 23, 2019	3-7

Statutes

29 U.S.C. § 794	3, 1-1, 1-4, 2-6
42 U.S.C. § 12101	2-1
42 U.S.C. § 12131	1-4
42 U.S.C. § 12132	3, 1-1, 1-4, 2-4, 8-1
42 U.S.C. § 12143	2-5
42 U.S.C. § 12182	12-9
ADA Amendments Act of 2008, Pub. L. No. 110-325, 122 Stat. 3553	1-7, 7-2
Amendment of Twenty-First Century Communications and Video Accessibility Act of 2010, Pub. L. No. 111-265, 124 Stat. 2795 (2010)	6-8, 6-10
Americans with Disabilities Act of 1990 ("ADA"), 42 U.S.C. §§ 12131-12149	1-15
Apprehension by peace officer of person believed to require emergency intervention--Transportation to appropriate regional facility, S.D.C.L. § 27A-10-3	9-9
Health Insurance Portability and Accountability Act of 1996, Pub.L. 104–191, 110 Stat. 1936, 29 U.S.C. § 1181. (HIPPA).....	12-2
Help America Vote Act of 2002 (HAVA), Pub. L. No. 107-252, 116 Stat. 1666-1730 (2002), I at 42 U.S.C. §§ 15301-15545, 15481 ("HAVA Section 301").	13-2
Patient Protection and Affordable Care Act, Pub.L. 111-148 , 124 Stat. 119 (2010) (codified as amended at 42 U.S.C. § 18001 (Supp. 2010)).	12-1
Revised Ordinances of Sioux Falls, SD, §§ 96.100 – 96.105 (concerning snow removal)	2-12
Section 504 of the Rehabilitation Act of 1973, 29 U.S.C. § 794.....	1-15

Other Authorities

2010 Census	1-20
<i>Access To Medical Care For Individuals With Mobility Disabilities</i> , U.S. Department of Justice, Civil Rights Division, U.S. Department of Health and Human Services Office for Civil Rights....	12-1, 12-4, 12-5, 12-6
<i>Accessibility of State and Local Government Websites to People with Disabilities</i> . Available at www.usdoj.gov/crt/ada/websites2.htm	6-7
<i>ADA Business BRIEF: Communicating with People Who Are Deaf or Hard of Hearing in Hospital Settings</i> , U.S. Department of Justice, Civil Rights Division, Disability Rights Section (DOJ Hospital Hearing Brief)	12-7, 12-8
ADA Checklist for Emergency Shelters, July 26, 2007. Available at http://www.ada.gov/pcatoolkit/chap7shelterchk.htm	8-3, 8-4
ADA Checklist for Polling Places.....	13-2, 13-4
<i>An Alternative to the Police: New Funding is Available for Mental Health Mobile Crisis Teams</i> , Bazelon Center for Mental Health Law	9-6, 9-11
<i>Average Weather for Sioux Falls, SD – Temperature and Precipitation</i> , The Weather Channel.	1-20
<i>Center for Independence of the Disabled New York (CIDNY), et al. v. City of New York, et al.</i> , Civ. 14 CV 5884 (S.D.N.Y. Mar. 13, 2019).....	1-14
Commonly Asked Questions about the Americans with Disabilities Act and Law Enforcement, U.S. Dept. of Justice (“DOJ Law Enforcement FAQ”). Available at http://www.ada.gov/q&a_law.htm	9-1, 9-3, 9-6, 9-7
Council of State Governments Justice Center, <i>Criminal Justice/Mental Health Consensus Project</i> (Consensus Project Report)	9-4
Dennis Debbaudt, <i>Autism & Law Enforcement: 25 Field Response Tips</i>	9-4
<i>Department of Justice/Department of Transportation Joint Technical Assistance on the Title II of the Americans with Disabilities Act Requirements to Provide Curb Ramps when Streets, Roads, or Highways are Altered through Resurfacing</i>	3-2
<i>DOJ ADA Best Practices Tool Kit for State and Local Government</i> (DOJ ADA Emergency Tool Kit). Available at http://www.ada.gov/pcatoolkit/chap7emergencymgmt.htm	8-1
EEOC ADA Fact Sheet	7-3
Frederick D. Isler, Associate Administrator for Civil Rights, <i>Memorandum, Public Rights-of-Way Access Advisory</i> , U.S. Department of Transportation, Federal Highway Administration, January 23, 2006 ...	3-3, 3-8, 3-9

Guidance on Planning for Integration of Functional Needs Support Services in General Population Shelters, FEMA. Nov. 2010 (FEMA FNSS Guidance).....	8-5, 8-6
H.R. Rep. No. 101-485.....	9-3
<i>Healthy People 2010</i> , U.S. Department of Health and Human Services (Nov. 2000).....	4-1
HHS <i>Civil Rights Clearance for Medicare Provider Applicants</i>	12-2
Irene Rico, U.S. DOT, FHWA. ADA transition plan process [memorandum]. Nov. 12, 2015	3-6
Kailes, <i>Emergency Preparedness: Taking Responsibility for Your Safety, Tips for People with Access and Functional Needs Limitations</i>	8-10
Mike Marshall, <i>Playground Surfacing Materials, ADA-Approved and Non-Approved</i>	4-3
Model Policy for Law Enforcement on Communicating with People who are Deaf or Hard of Hearing...	9-8
Questions and Answers: The Americans with Disabilities Act and Persons with HIV/AIDS, U.S. Dept. of Justice.....	12-9
U.S. Department of Health & Human Services, Centers for Disease Control, <i>Disability Impacts Us All</i>	1-2
U.S. Department of Justice, Civil Rights Division, Disability Rights Section, Americans With Disabilities Act, ADA Update: A Primer for State and Local Governments	1-1
United Nations Convention on the Rights of Persons with Disabilities.....	1-16
Web Content Accessibility Guidelines (WCAG) 2.1, June 5, 2018	1-12
Written testimony of Jill Houghton, US Business Leadership Network, to U.S. Senate, Health, Education, Labor and Pensions Committee	2-2
U.S. Department of Health & Human Services, Centers for Disease Control, Disability Impacts Us All, 61 million adults in the U.S. with a disability, 26% of adults in the United States have some type of disability; A Snapshot of Disability in South Dakota, https://www.cdc.gov/ncbddd/disabilityandhealth/impacts/pdfs/SouthDakota_Disability.pdf	1.1
U.S. Department of Justice, Civil Rights Division, Disability Rights Section, Americans with Disabilities Act ADA Guide for Small Towns, (last updated: August 20, 2007), https://www.ada.gov/smtown.htm#anchor23988	1.1

Regulations

28 C.F.R. § 35.130.....	1-5
-------------------------	-----

28 C.F.R. § 35.104	1-4
28 C.F.R. § 35.130	1-4, 1-5, 2-4
28 C.F.R. § 35.149	1-6
28 C.F.R. § 35.150	1-6, 1-7, 3-4, 3-5
28 C.F.R. § Part 35	1-4
28 C.F.R. §§ 35 & 36; 82 FR 60932 (Dec. 26, 2017), Nondiscrimination on the Basis of Disability; Notice of Withdrawal of Four Previously Announced Rulemaking Actions.	1-11
28 C.F.R. §§ 35.150(d)(2).....	3-2
28 C.F.R. §35.160	6-1, 6-2
28 C.F.R. §35.161	6-1
28 C.F.R. §35.162	6-2
49 C.F.R. § Part 37	1-4
49 C.F.R. § 37.121	2-5
49 C.F.R. § 37.3	1-4, 2-5
49 C.F.R. §37.137	2-3
60 Fed. Reg. 58462.....	3-5
<i>Access Board Public Rights-of-Way Guidelines</i>	3-8, 3-21
ADA Accessibility Guidelines for Buildings and Facilities	11-2
<i>Americans with Disabilities Act (ADA) Accessibility Guidelines for Buildings and Facilities: Public Rights-of- Way</i> , 76 Fed. Reg. 44664, 44688 (Published July 26, 2011)	3-1
<i>Americans With Disabilities Act (ADA) Accessibility Guidelines for Buildings and Facilities: Public Rights- of-Way</i> , 76 Fed. Reg. 44664, 44688 (Published July 26, 2011)	2-6
<i>Coronavirus and COVID-19</i>	7-4
<i>Medicare and Medicaid Programs; Emergency Preparedness Requirements for Medicare and Medicaid Participating Providers and Suppliers</i> , Department of Health and Human Services , Centers for Medicare & Medicaid Services, 78 F.R. 79082 (Dec. 27, 2013).	12-3

Nondiscrimination on the Basis of Disability by Public Accommodations and in Commercial Facilities; Swimming Pools, U. S. Department of Justice, RIN 1190-AA46, 77 Fed. Reg. 16163 (Mar. 20, 2012) (“March 2012 DOJ ADA Swimming Pool Rule”). 4-3

Nondiscrimination on the Basis of Disability in State and Local Government Services, U. S. Department of Justice, RIN 1190-AA46, 75 Fed. Reg. 56164 (Sept. 15, 2010) (“2010 DOJ ADA Regulations”). passim

Nondiscrimination on the Basis of Disability in State and Local Government Services; Nondiscrimination on the Basis of Disability by Public Accommodations and in Commercial Facilities, U.S. Department of Justice, 69 F.R. 58768, 58777 (Sept. 30. 2004) (“2004 DOJ ADA ANPRM”)..... 3-5

Nondiscrimination on the Basis of Disability; Accessibility of Web Information and Services of State and Local Government Entities and Public Accommodations, U.S. Department of Justice, RIN 1190-AA61; 75 Fed. Reg. 43460, 43464 (July 26, 2010)). 1-10, 6-3, 11-3

Regulations to Implement the Equal Employment Provisions of the Americans With Disabilities Act, as Amended. 76 F.R. 16977 7-3

Transportation for Individuals with Disabilities at Intercity, Commuter, and High Speed Passenger Railroad Station Platforms; Miscellaneous Amendments, U.S. Department of Transportation, RIN 2105–AD54. 76 Fed. Reg. 57924, 57931-57932 (amending 49 CFR Parts 37 and 38) (Sept. 19, 2011). 2-6

What You Should Know About COVID-19 and the ADA, the Rehabilitation Act, and Other EEO Laws, Technical Assistance Questions and Answers 7-4

Treatises

Andrew C. Porter, *Toward a Constitutional Analysis of the Right to Intrastate Travel*, 86 Nw. U. L. Rev. 820, 829 (1991-1992)..... 2-1

Chilton EE. *Ensuring effective communication: the duty of health care providers to supply sign language interpreters for deaf patients*. Hastings L.J., 1996;47:871-910..... 12-7

Dennis Debbaudt and Darla Rothman, Ph. D., *Contact with Individuals with Autism, Effective Resolutions*. FBI Law Enforcement Bulletin, Vol 70, No. 4 (April 2001)..... 9-4

Dilip Jeste, Graham Eglit, Barton Palmer, Jonathan Martinis, Peter Blanck, & Elyn Saks, *An Overview of Supported Decision in Serious Mental Illnesses*, 81 *Psychiatry* 28 (2018) 9-5

Elizabeth Hervey Osborn, *What Happened to ‘Paul’s Law’?: Insights on Advocating for Better Training and Better Outcomes in Encounters Between Law Enforcement and Persons with Autism Spectrum Disorders*, 79 Univ. of Col. L. Rev., Issue 1, 333, 341(Winter 2008)..... 9-4

Helping Americans Vote: Poll Workers, The Pew Center on the States, Sept. 2007. 13-3

Hoffman, J. M., Shumway-Cook, A., Yorkston, K. M., Ciol, M. A., Dudgeon, B.J., & Chan, L. *Association of mobility limitations with health care satisfaction and use of preventive care: A survey of Medicare beneficiaries*. Archives of Physical Medicine and Rehabilitation, Vol. 88, Issue 5, 583-588 (May, 2007).
..... 12-4

Jennifer Fischer, Student Article, *The Americans with Disabilities Act: Correcting Discrimination of Persons with Mental Disabilities in the Arrest, Post-Arrest, and Pretrial Processes*, 23 LAW & INEQ. 157, 195 (2005) 9-2

Nancy R. Mudrick & Sylvia Yee, *Defining Programmatic Access to Healthcare for People with Disabilities* (“Defining Programmatic Access”) DREDF, Spring, 2007..... 12-10, 12-13, 12-15

Peter Blanck & Jonathan Martinis, *“The right to make choices”*: National Resource Center for Supported Decision-Making, 3 *Inclusion* 24 (2015) 9-5

Peter Blanck, *eQuality: The Struggle for Web Accessibility by Persons with Cognitive Disabilities* (Cambridge University Press 2014)..... 6-3

Peter Blanck, Eve Hill, Charles Siegal, & Michael Waterstone, *DISABILITY CIVIL RIGHTS LAW AND POLICY*, Second Edition, Thomson/West Publishers (2009) 1-15

Universal design for local transport – some European experiences, International Centre for Accessible Transportation 1-17, 2-3

Acknowledgments

This updated 2021 ADA Transition report would not have been possible without the generous assistance from many diverse stakeholders, beginning with Mayor Paul TenHaken, and staff throughout the Sioux Falls City government and Sioux Area Metro, particularly Daniel Haggar (prior ADA Coordinator), Sharla Svennes (ADA Coordinator), Wes Philips (Principal Engineer), Eric Bogue (Assistant City Attorney, Public Works Department), Heath Hoftiezer (Principal Engineer), Tory Miedema (Park Development Specialist), Jane Hannestad (Human Resources Manager), Sam Trebilcock (Senior Planner, Shawna Goldammer (Planning Projects Coordinator, Jeff Eckhoff (Director of Planning & Development Services), Sandy Frentz (Public Health Manager), Jeff Helm (Fire Division Chief), Regan Smith (Emergency Manager), Jason Leach (Police Lieutenant), Sarah Van Voorst – (Police Community Resource Officer - Mental Health Officer), Mike Grigsby (Director of Innovation & Technology), Elizabeth Ahlers (Digital Services Coordinator), Alicia Collura (Assistant Director of Public Health), Monique Christensen (Assistant Library Director), Steve Watkins (LifeScape), Nathan Stallinga (DakotAbilities), Vicki Stewart, Carla Miller (CEO, SD Parent Connection), Nancy Wehrkamp (Active Generations), and Kristi Allen (PVA).

Our analysis is also informed by our experience producing our 2015 draft ADA Transition report and the generous assistance from diverse stakeholders, beginning with Mayor Mike Huether and his call to look at all issues thoroughly, staff throughout Sioux Falls City government and Sioux Area Metro, particularly Dave Pfeifle (City Attorney), Colleen Moran (Assistant City Attorney and ADA Coordinator), Dennis Erckfritz (SAM Operations Manager), Randy Hartman (SAM Assistant General Manager), Jeff DesLauriers (Assistant City Engineer),

Jan Clary (Engineering Technician), Dave Fisher (Assistant Director of Parks), Lorie Hogstad (City Clerk) and Bob Litz (Minnehaha County Auditor), the City Council, and input from individuals, and public and non-governmental organizations, including members of the ADA Accessibility Review Board, board members of the Disability Awareness Commission, Sioux Falls Independent Living Choices, DakotAbilities, South Dakota Achieve, and the Rehab Center for the Blind and Visually Impaired.

The views herein reflect only ours as consulting researchers, which may be subject to updating and change as this area and information evolves, and not necessarily that of the City of Sioux Falls or any other public or private entity, nor do the views herein reflect legal opinions.

Executive Summary

The Americans with Disabilities Act (ADA), passed in 1990, prohibits public entities, such as the City of Sioux Falls (City) and Sioux Area Metro (SAM), from discriminating against people with disabilities. Public entities must ensure that no qualified individual with a disability, on the basis of disability, be excluded from participation in or denied the equal benefits of the services, programs, and activities of a public entity, or face discrimination by any such entity.¹ This requirement applies to all aspects of the City and SAM services, programs, and activities. Because the City and SAM receive federal funding through different programs, discrimination is also prohibited by Section 504 of the Rehabilitation Act of 1973 (Section 504).²

One of the ADA's provisions is a requirement that public entities produce updated "transition reports" and/or "self-evaluation" reports. In 2015, the City and the Mayor commissioned the authors to begin the review of facts and law related to the City's and SAM's policies and practices, and to help develop a comprehensive ADA transition report, which was submitted to the City as a prior draft 2015 ADA Transition Report. Subsequently, the City and the Mayor commissioned the authors to review the facts and law related to the City's and SAM's policies and practices and to develop this updated 2021 ADA Transition Report.

Activities informing the initial 2015 draft report and this subsequent 2021 updated report include analysis of: (1) standards; (2) reports from government and nongovernmental organizations; (3) studies of disability factors; (4) court documents such as complaints, consent decrees and settlements, and case decisions; (5) scholarly and practice articles; (6) information

¹ 42 U.S.C. § 12132.

² 29 U.S.C. § 794.

from discussions and interviews (in-person and electronically) with citizens and leaders from the disability community in Sioux Falls, as well as with City and SAM staff; (7) review of relevant City and SAM documents; and (8) tours of relevant City and SAM facilities.

Observations and Recommendations, which are described in this report, are summarized as follows:

Transportation

1. Continue to Investigate options to decrease reliance on the Paratransit system, primarily by improving other aspects of City and SAM transportation.
2. Improve snow removal enforcement and implementation of City snow removal efforts to conform to the standard.
3. Improve systems to monitor sidewalk maintenance issues, particularly near bus stops.
4. Investigate and publicize systems to improve communication between Paratransit riders and drivers.
5. Improve integration between SAM and other City departments to streamline maintenance and capital improvement efforts.
6. Investigate the feasibility of adding electronic signage on its current fixed-route buses to assist riders with auditory and cognitive disabilities.
7. Ensure City and SAM follow-through on planned efforts to minimize negative effects of changes and reductions in Paratransit.

Sidewalks and Public Rights of Way

1. Implement effective plan to install curb ramps, improve sidewalks, and other aspects of public rights of way where necessary.
 - i. In part in response to a citizen complaint, in 2018 the City adopted an expanded transition plan addressing public rights of way. Available at: <https://www.siouxfalls.org/public-works/engineering/sidewalks/transition-plan>.
2. Improve review systems for sidewalk maintenance.
3. Increase Public Works staff review of sidewalk conditions to maintain compliance with Sidewalk Plan agreement and speed notice to landowners

for sidewalk repair. If necessary to accomplish this, add staff to this role in Engineering.

4. Continue to monitor systems so that when developers build new projects, they build as agreed upon and promised.
5. Consider accessible on-street parking requirements.

Parks and Recreation

1. Many parks are renovated per the capital improvement plan and built in compliance with ADA guidelines at the time. SFPR has followed prior recommendations in transition plans for existing playing fields to make 50% of each type of field at parks accessible, served by an accessible route and with accessible viewing area. At parks where greater than 50% of the fields may easily be made accessible, the greater percentage was recommended.
2. The City is working to increase connectivity between accessible components in parks.
3. Four of the City's pools have sloped entry "zero depth" pools, designed to permit persons in wheelchairs to roll into the water and swim without special assistance. This appears to comply with the latest DOJ requirements.
4. Three of the City's golf courses are largely accessible. SFPR is working with the course management to acquire accessible golf carts.
5. SFPR has worked with others to modify policies. For example, it worked with South Dakota Fish & Game to allow a resident to use an electric trolling motor at Family Park.
6. SFPR has worked to develop its bike trail system in an accessible manner.
7. SFPR is proactive in developing park system and increased accessibility as a result). SFPR works with third parties seeking to host events in the parks to ensure that access issues are addressed in the event planning stage.
8. SFPR has instituted policy guidance to clarify that power wheelchairs and Other Power Driven Mobility Devices (e.g., Segways) are permitted on most bike paths and hiking trails.

Administrative Requirements and ADA Coordinator

1. The City has enacted a series of Executive Orders to ensure compliance with the ADA.

2. The City ADA Coordinator has responsibility to address issues related to disability, including coordinating compliance efforts, overseeing grievance procedures, and development of the City's ADA Transition Plan.
3. All employees are informed of the City's non-discrimination and reasonable accommodation policies, and ADA Coordinator conducts training on this subject as part of all new employee training.
4. The City has a procedure for complaints of disability discrimination.
5. People with disabilities and groups representing people with disabilities are regularly engaged with evaluating new construction, retrofits, and other issues and policies through the Disability Awareness and Accessibility Review Board (prior to April 2019, through the ADA Accessibility Review Board).
6. The City requires all entities using any City facilities for activities open to the public to follow published procedures to ensure accessibility.

Effective Communications & Technology

1. The City has identified sources of qualified sign language and oral interpreters, and services are available 24 hours per day, 365 days per year. The City has a standing contract to provide sign language translators.
 - a) The City should consider clarifying its contracts to ensure that interpreters are available within a given period of time to ensure services are available in a reasonable time.
2. The City can produce braille documents upon request.
3. City / County 911 service, City Hall, and the Sioux Falls Police Departments have working TTY equipment and accept relay calls.
4. The City provides captioning for its cable programming.
5. The City's website is largely accessible, although an initial review has shown several issues that the City is working to address.
 - a) The City needs to ensure that content added from all departments is hosted in an accessible manner.
 - b) The City should provide captioning for video content hosted on its website, or at a minimum ensure communications provided by video are transmitted in an equally effective manner regardless of the mechanism.
 - c) Personnel should continue to review and scrub the website. It may help to enlist the public, particularly those with disabilities, in this effort.

Employment and Human Relations Department

1. Sioux Falls instituted policies to ensure compliance with the ADA's employment non-discrimination requirements. All employees are informed of the City's non-discrimination policies and new employees receive training conducted by the City ADA Coordinator, amongst others. The City has adopted an affirmative action plan that includes disability as a category for which it seeks to increase the employment of people with disabilities by the City.
2. The City has an affirmative action mandate in its policies. Broadly speaking, the City may wish to consider strategies to direct employment notices to groups and organizations consisting of, or representing, people with disabilities to increase awareness of job openings.

Emergency Management

1. The Office of Emergency Management, working in conjunction with all City departments and other regional government and non-governmental organizations, has produced substantial emergency management plans. The planning addresses people with disabilities at various levels.
2. The City has worked with regional partners, hospitals, the Red Cross, community-based organizations, and other agencies that support people with disabilities and other at-risk populations.
3. The City has run exercises to test preparedness, and people with disabilities have been part of these.
4. The City has systems that include accessible features for notification, including Closed Captioning, a 211 helpline system, text messaging systems, and specialized NOAA weather radios.
5. All of the City's 19 shelters, in conjunction with the Red Cross, are accessible. All will accept service animals with residents with disabilities.
6. The City has plans with partners to store and acquire durable medical equipment and to provide assistance after an emergency.
7. The City has developed a "Sioux Falls COVID-19 Response" website and information center.

Police Procedures

1. SFPD adopted written policies that address areas related to disability, and all 264 police officers receive training on disability issues as part of standard training and additional departmental training addressing these policies.
2. SFPD sought to improve responses to mental health crises by creating Crisis Intervention Teams (CIT), working with health care providers and others to create Mobile Crisis Teams (MCT).
 - a) We recommend that appropriate personnel develop a system to analyze and learn more from such responses.
 - b) The City should consider whether there are opportunities available under the 2021 COVID-19 relief bill, the American Rescue Plan, which contains new federal funding to support an expansion of mental mobile crisis teams.
3. In 2020, SFPD added a Mental Health Community Resource Officer position, intended to be department subject matter expert on mental health and addiction/substance abuse with law enforcement role, and to work with individuals, families, community groups, and providers. She works with the Sioux Falls Mental Health Court, a specialized court established by the state.
4. Officers are instructed to use discretion when transporting prisoners with disabilities and have accessible vans.
5. SFPD policies and guidance require officers to provide interpreters for victims, witnesses, & suspects who may be deaf or hard of hearing.

Other City Buildings and Programs

1. Programs of the Sioux Falls Arena and Convention Center are evaluated for program accessibility to persons with disabilities of all types. In response to complaints in the mid to late 1990s, modifications to facilities and policies were made in a cooperative fashion and in settlement of a formal complaint.
2. The Denny Sanford Premier Center is ADA compliant. The ADA Accessibility Review Board and others representing people with disabilities were involved in the design process and have had a meaningful opportunity to inform the plans. Initial seating designs were lacking some in vertical and horizontal seating integration / dispersion. This observation by the board and others resulted in changes and improvements.
 - a) The City should consider captioning on the scoreboards or at the least, provide information via other avenues (e.g., using video monitors or other technologies);
3. Washington Pavilion was renovated in 1999 and was designed and constructed to be fully compliant with ADA Accessibility Guidelines.

4. The City should ensure that ticketing policies at all ticketed events comply with new DOJ requirements.

Libraries

1. Each of the five City branches is physically accessible and newly constructed or renovated to comply with the ADA, including the ADAAG requirements specific to libraries.
2. Staff should evaluate whether additional accessible terminals are needed at each branch.
3. Staff should investigate more accessible options for the online systems.

Health Care

1. The main Falls Community Health (“FCH”) clinic downtown was renovated in 2007 and is ADA compliant in construction.
2. In response to the authors’ observations, FCH purchased an accessible dental lift chair, accessible medical exam table and wheelchair accessible scale. FCH personnel report staff are trained in how to use the tables.
3. Staff developed documented policies and training on disability issues to better ensure equitable treatment. We recommend staff consider expanding these policies and training to ensure equitable treatment.

Voting

1. Sioux Falls conducts elections on the second Tuesday of April in even-numbered years using 67 voting precincts located at approximately 55 locations throughout the City.
2. A comprehensive review of accessibility at all polling locations has not been done recently, but a review of exterior accessibility was conducted in July 2020 by the PAVA lead for Disability Rights South Dakota. Care is taken to ensure selected polling locations are ADA accessible. Locations are typically public buildings or churches.
3. The City deploys ExpressVote ballot marking devices to all polling places.
4. Polling place workers (Superintendents and Deputies) receive training on ExpressVote set-up and use prior to the election. Additionally, polling place workers receive instructions on providing assistance to voters who are

unable to read or mark a ballot because of disability, physical limitation, or limited English proficiency (SDCL 12-18-25).

This summary, and its recommendations, support full compliance with, and attempt to suggest transcendence of, the City's and SAM's obligations under federal law. By endeavoring to improve accessibility and universal design for all of its citizens, Sioux Falls will maintain its stance as a model, livable city in terms of approaches to accessibility, programs, services, and design.³ These efforts will improve the usability and livability of the City for all its citizens of all ages, visitors of all ages, businesses, and public institutions.

³ See generally Global Universal Design Commission, at <http://www.globaluniversaldesign.org/> (Blanck GUDC Chair).

I. Introduction

The Americans with Disabilities Act (ADA) of 1990 (title II) prohibits public entities, such as the City of Sioux Falls (City) and Sioux Area Metro (SAM), from discriminating against people with disabilities. Public entities must ensure that no qualified individual with a disability, on the basis of disability, is excluded from participation in or denied the equal benefits of the services, programs, and activities of a public entity, or face discrimination by any such an entity.⁴

These ADA title II requirements apply to all aspects of the City and SAM services, programs, and activities. Because the City and SAM receive federal funding through different programs, discrimination is also prohibited by Section 504 of the Rehabilitation Act of 1973 (Section 504).⁵

One of the ADA's provisions is a requirement that public entities produce updated "transition" and "self-evaluation" plans or reports.⁶ The U.S. Department of Justice, Civil Rights Division, Disability Rights Section, notes:

If a town with 50 or more employees decides to make physical changes to achieve program access it must develop a written plan that identifies the modifications that will be made. The plan should include timelines for completing these modifications. Interested parties, including people with disabilities and organizations representing people with disabilities, must at a minimum have an opportunity to participate in the development of the plan by

⁴ 42 U.S.C. § 12132.

⁵ 29 U.S.C. § 794.

⁶ For example, see U.S. Department of Justice, Civil Rights Division, Disability Rights Section, Americans With Disabilities Act, ADA Update: A Primer for State and Local Governments (last updated: June 8, 2015), at: https://www.ada.gov/regs2010/titleII_2010/title_ii_primer.html#coordinator.

Chapter 1 - Overview

submitting comments. A copy of the plan and a copy of the self-evaluation must be available for public inspection for three years after completion.⁷

The ADA recognizes that disability is a common and natural part of the human experience.⁸ Recent estimates indicate twenty-five point six percent (25.6%) of the U.S. population have a disability.⁹ According to the Centers for Disease Control (CDC) 25.6% of adults in the U.S. have some type of disability compared to 23.4 % of adults in South Dakota.¹⁰

Comparing the CDC estimates nationally (percentage of adults with functional disability) to South Dakota, the CDC finds: Mobility 12.9% v. 10.8%, Cognition 11.4% v. 9.6%, Independent Living 7.0% v. 5.9%, Hearing 5.6% v. 7.0%, Vision 4.7% v. 3.5%, Self-Care 3.8% v. 2.9%. Note that South Dakota has a higher proportion of individuals with hearing disabilities than the national average.¹¹

⁷ U.S. Department of Justice, Civil Rights Division, Disability Rights Section, Americans with Disabilities Act, ADA Guide for Small Towns, (last updated: August 20, 2007), <https://www.ada.gov/smtown.htm#anchor23988>.

⁸ For an overview, see Peter Blanck, *Disability Law and Policy: 2020* (Foundation Press); see also Peter Blanck, Why America is Better Off Because of the Americans with Disabilities Act and the Individuals with Disabilities Education Act, 35 *Touro L. Rev.* 605 (2019).

⁹ See U.S. Department of Health & Human Services, Centers for Disease Control, *Disability Impacts Us All*, 61 million adults in the U.S. with a disability, 26% of adults in the United States have some type of disability, at <https://www.cdc.gov/ncbddd/disabilityandhealth/infographic-disability-impacts-all.html>. For earlier estimates, see for example Matthew W. Brault, *Americans with Disabilities: 2010*. Available at: <http://www.census.gov/prod/2012pubs/p70-131.pdf>. Prevalence and Most Common Causes of Disability Among Adults -- United States, 2005, Morbidity and Mortality Weekly Report (MMWR), 58(16);421-426 (May 1, 2009) (MMR Report). Available at: <http://www.cdc.gov/mmwr/preview/mmwrhtml/mm5816a2.htm>.

¹⁰ U.S. Department of Health & Human Services, Centers for Disease Control, *Disability & Health U.S. State Profile Data for South Dakota (Adults 18+ years of age)*. Available at <https://www.cdc.gov/ncbddd/disabilityandhealth/impacts/south-dakota.html>.

¹¹ *Id.*

Chapter 1 - Overview

Comparing the CDC estimates nationally (percentage of adults with functional disability) to South Dakota, the CDC also finds that adults with disabilities are more likely to: be inactive (U.S. 42.2%, South Dakota 36.9%), have high blood pressure (U.S. 41.9%, South Dakota 36.7%), smoke (U.S. 27.8%, South Dakota 33.3%), and have obesity (U.S. 39.5%, South Dakota 41.1%).¹² This suggests that, as compared to national percentages, South Dakotans tend to be somewhat more active and have lower blood pressure, but are more likely to smoke and have obesity.¹³ The CDC concludes that: “Despite progress, adults with disabilities in South Dakota and across the country continue to experience significant differences in health characteristics and behaviors compared to adults without disabilities.”¹⁴

The City and the Mayor have commissioned the authors to review and analyze facts, relevant materials, and law related to the City’s and SAM’s policies and practices, and to develop this review and updated 2021 ADA Transition Report. In this chapter, we discuss general requirements of federal laws and regulations, and factors of the Sioux Falls area that affect all aspects of government. In subsequent chapters, we focus on governmental units and services and elaborate on particular requirements.

II. Federal Disability Law

A. Federal Requirements

¹² *Id.*

¹³ *Id.*

¹⁴ *Id.*

Chapter 1 - Overview

The Americans with Disabilities Act (ADA), passed in 1990, prohibits title II public entities, such as the City of Sioux Falls (City) and Sioux Area Metro (SAM), from discriminating against people with disabilities. Public entities must ensure that no qualified individual with a disability,¹⁵ on the basis of disability, is excluded from participation in, or denied the equal benefits of, the services, programs, and activities of a public entity, or face discrimination by any such an entity.¹⁶

The City and SAM may not contract away their ADA requirements.¹⁷ Public entities that receive federal funding, like the City and SAM, also are prohibited from discrimination against people with disabilities by Section 504 of the Rehabilitation Act of 1973 (Section 504).¹⁸ Because the ADA and Section 504 largely overlap, we focus on the ADA for simplicity.¹⁹ Other federal laws also prohibit discrimination (for example, in housing), but are largely beyond the scope of this current review and report.

¹⁵ The term "qualified individual with a disability" means an individual with a disability who, with or without reasonable modifications to rules, policies, or practices, the removal of architectural, communication, or transportation barriers, or the provision of auxiliary aids and services, meets the essential eligibility requirements for the receipt of services or the participation in programs or activities provided by a public entity. 42 U.S.C. § 12131.

¹⁵ 42 U.S.C. § 12132. The City of Sioux Falls, a municipality within the State of South Dakota, is a "public entity" within the meaning of the ADA (Title II), 42 U.S.C. § 12131(1), 28 C.F.R. § 35.104, and 49 C.F.R. § 37.3, and is, therefore, subject to title II of the ADA, 42 U.S.C. §§ 12131 et seq., and its implementing regulations, 28 C.F.R. § Part 35 and 49 C.F.R. § Part 37. Sioux Area Metro (SAM) is an agency of the City of Sioux Falls, which operates a public transportation system. Sioux Area Metro is a "recipient" of "federal financial assistance" and is therefore subject to section 504, 29 U.S.C. § 794, and the relevant implementing regulations, 49 C.F.R. Parts 27 and 37.

¹⁶ *Id.*

¹⁷ 28 C.F.R. § 35.130(b).

¹⁸ Section 504, 29 U.S.C. § 794.

¹⁹ Moreover, unlike section 504 of the Rehabilitation Act of 1973, which only covers programs receiving Federal financial assistance, ADA title II extends to all the activities of state and local governments whether or not they receive federal funds.

Chapter 1 - Overview

The U.S. Department of Justice (DOJ) and the U.S. Department of Transportation (DOT)²⁰ have produced regulations to expand on what constitutes prohibited disability discrimination. The DOJ regulations applicable to the City (and not necessarily applicable to SAM, as discussed below) define general prohibitions against discrimination.²¹ Under these regulations, state and local governments:

- May not refuse to allow a person with a disability to participate in a service, program, or activity simply because the person has a disability.
- Must provide programs and services in an integrated setting, unless separate or different measures are necessary to ensure equal opportunity.
- Must eliminate unnecessary eligibility standards or rules that deny individuals with disabilities an equal opportunity to enjoy their services, programs or activities unless "necessary" for the provisions of the service, program or activity. Requirements that tend to screen out individuals with disabilities, such as requiring a driver's license as the only acceptable means of identification, are also prohibited.
- Safety requirements that are necessary for the safe operation of the program in question, such as requirements for eligibility for drivers' licenses, may be imposed if they are based on actual risks and not on mere speculation, stereotypes, or generalizations about individuals with disabilities.
- Are required to make reasonable modifications in policies, practices, and procedures that deny equal access to individuals with disabilities, unless a fundamental alteration in the program would result.
- Must furnish auxiliary aids and services when necessary to ensure effective communication, unless an undue burden or fundamental alteration would result.
- May provide special benefits, beyond those required by the regulation, to individuals with disabilities.
- May not place special charges on individuals with disabilities to cover the costs of measures necessary to ensure nondiscriminatory treatment, such as making modifications required to provide program accessibility or providing qualified interpreters.

²⁰ Department of Transportation regulations are discussed in detail *infra* in the transportation chapter.

²¹ 28 C.F.R. § 35.130.

- Shall operate their programs so that, when viewed in their entirety, they are readily accessible to and usable by individuals with disabilities.

As discussed below, these general prohibitions apply to all governmental programs and services.

The DOJ regulations require what is known as “program accessibility.” Under this requirement, “no qualified individual with a disability shall, because a public entity's facilities are inaccessible to or unusable by individuals with disabilities, be excluded from participation in, or be denied the benefits of the services, programs, or activities of a public entity, or be subjected to discrimination by any public entity.”²² Where existing facilities are inaccessible, public entities are not required to make each accessible, but the public entity must “operate each service, program, or activity so that the service, program, or activity, when viewed in its entirety, is readily accessible to and usable by individuals with disabilities.”²³

The covered entity is not required to take any action that it can prove “would result in a fundamental alteration in the nature of a service, program, or activity or in undue financial and administrative burdens.”²⁴ A public entity may achieve program accessibility through such means as:

redesign or acquisition of equipment, reassignment of services to accessible buildings, assignment of aides to beneficiaries, home visits, delivery of services at alternate accessible sites, alteration of existing facilities and construction of new facilities, use of accessible rolling stock or other conveyances, or any other

²² 28 C.F.R. § 35.149.

²³ 28 C.F.R. § 35.150.

²⁴ 28 C.F.R. § 35.150(a)(3).

methods that result in making its services, programs, or activities readily accessible to and usable by individuals with disabilities.²⁵

However, when choosing among available methods for meeting program accessibility, a public entity must “give priority to those methods that offer services, programs, and activities to qualified individuals with disabilities in the most integrated setting appropriate.”²⁶ These requirements apply to all aspects of government except transportation.

Transportation entities such as Sioux Area Metro are primarily subject to the DOT regulations, and not to the DOJ regulations.²⁷ However, the DOT ADA regulations state that entities subject to DOT’s ADA regulations may also be subject to the ADA regulations of the Department of Justice.²⁸ As stated in the preamble to § 37.21(c) in the DOT’s 1991 regulation: “[t]he DOT rules apply only to the entity’s transportation facilities, vehicles, or services; the DOJ rules may cover the entity’s activities more broadly.”²⁹ The specifics of the DOT transportation regulations are discussed in detail in chapter II of this report.

Congress amended the ADA, effective January 1, 2009, to expand the scope of those who are considered to be disabled and, thus, entitled to protection under the ADA.³⁰ The express terms of the ADA Amendments Act (ADAAA) apply this expanded definition of disability

²⁵ 28 C.F.R. § 35.150(b).

²⁶ *Id.*

²⁷ See 28 C.F.R. § 35.102(b) (“To the extent that public transportation services, programs, and activities of public entities are covered by subtitle B of title II of the ADA (42 U.S.C. § 12141), they are not subject to the requirements of” the DOJ ADA regulations.). See also 75 Fed. Reg. 56167 (discussing distinction).

²⁸ 49 C.F.R. § 37.21(c).

²⁹ 56 Fed. Reg. 45584, 45736 (Sept. 6, 1991).

³⁰ See ADA Amendments Act of 2008, Pub. L. No. 110-325, 122 Stat. 3553 (codified in scattered sections of 42 U.S.C.).

Chapter 1 - Overview

to all titles of the ADA, including title II, which is applicable to the City and SAM. 42 U.S.C. § 12102 (“As used in this *chapter*” where title II of the ADA is included in the chapter) (emphasis added).

Of particular analytical importance, the ADA Amendments Act repudiated the U.S. Supreme Court’s decisions in *Sutton v. United Air Lines, Inc.*, 527 U.S. 471 (1999), and *Toyota Motor Manufacturing, Kentucky, Inc. v. Williams*, 534 U.S. 184 (2002). Congress concluded these cases had imposed an unduly strict standard for determining whether an individual is disabled under the ADA.³¹ Congress thus made clear its intent that “the primary object of attention in cases brought under the ADA should be whether entities covered under the ADA have complied with their obligations, and . . . that the question of whether an individual’s impairment is a disability under the ADA should not demand extensive analysis.”³²

In 2010, the DOJ instituted a final rule to amend its implementing regulations of title II of the ADA.³³ Notable changes include: (1) adoption of additions to and revisions of the ADA Accessibility Guidelines for Buildings and Facilities (ADAAG), (2) clarifications of rules governing service animals (with the DOJ taking the position for the first time that service animals may only be dogs or small horses trained to do work or perform tasks for the benefit of an individual with a disability), (3) adoption of a two-tiered approach to mobility devices, drawing distinctions

³¹ ADA Amendments Act § 2(b), 122 Stat. at 3554.

³² *Id.* § 2(b)(5), 122 Stat. at 3554.

³³ *Nondiscrimination on the Basis of Disability in State and Local Government Services*, U. S. Department of Justice, RIN 1190-AA46, 75 Fed. Reg. 56164 (Sept. 15, 2010) (“2010 DOJ ADA Regulations”). Available at: <http://www.gpo.gov/fdsys/pkg/FR-2010-09-15/pdf/2010-21821.pdf>. This rule similarly does not directly apply to SAM, at least with regard to the transportation services, programs, and activities covered by ADA title II, part b.

Chapter 1 - Overview

between wheelchairs and "other power-driven mobility devices" such as Segways, (4) adoption of requirements regarding ticket sales at public events including requiring that a person purchasing a wheelchair-accessible seat at an event be able purchase three companion seats, and (5) changes to requirements for entities to provide effective communications including (a) new requirements that clarify that entities are required to communicate with appropriate companions (e.g., parents, spouses, etc.), (b) that entities cannot require people with communications disabilities bring family members or others to communicate, and (c) adoption of standards for video remote interpreting (VRI) services as a type of auxiliary aid that may be used to provide effective communication.³⁴

The rules include a general "safe harbor" provision under which elements in covered facilities built or altered in compliance with the 1991 ADAAG standards or the Uniform Federal Accessibility Standards (UFAS) are not required to be brought into compliance with the 2010 DOJ Standards until such facility elements are subject to a planned alteration.

The 2010 DOJ ADA regulations implementing the 2004 ADAAG change scoping for certain existing and new facilities of which the City should be aware. The 2010 regulations are particularly relevant to parks and recreation, and include recreational boating facilities; exercise machines and equipment; fishing piers and platforms; golf facilities; miniature golf facilities; play areas; saunas and steam rooms; and swimming pools, wading pools, and spas.³⁵ Medical facilities and correctional facilities are also affected.

³⁴ The complete federal regulations with changes integrated and noted in bold is available at: http://www.ada.gov/regs2010/titleII_2010/titleII_2010_withbold.htm.

³⁵ 2010 DOJ ADA Regulations, 75 Fed. Reg. at 56180.

Chapter 1 - Overview

The regulations clarify that when alterations are made to an existing structure “that affects or could affect the usability of or access to an area of a facility that contains a primary function” they must be “made so as to ensure that ... the path of travel to the altered area and the restrooms, telephones, and drinking fountains serving the altered area, are readily accessible to and usable by individuals with disabilities ... unless the cost and scope of such alterations is disproportionate to the cost of the overall alteration.”³⁶ A disproportionate cost is defined as one where the access features account for more than 20% of the total cost.³⁷

The ADA also requires government websites to be accessible. While the DOJ has been taking this position for some time in Project Civic Access settlements and elsewhere, the DOJ had been taking steps toward formalizing such requirements. In an Advance Notice of Public Rulemaking (ANPRM), the DOJ summarized its view that the ADA and Section 504, already require accessibility in governments’ websites as follows:

There is no doubt that the websites of state and local government entities are covered by title II of the ADA. *See* 28 C.F.R. 35.102 (providing that the title II regulation “applies to all services, programs, and activities provided or made available by public entities”). Similarly, there seems to be little debate that the websites of recipients of federal financial assistance are covered by section 504 of the Rehabilitation Act. The Department has affirmed the application of these statutes to websites in a technical assistance publication, *Accessibility of State and Local Government Websites to People with Disabilities* (available at: <https://www.ada.gov/websites2.htm>), and in numerous agreements with State and local governments and recipients of Federal financial assistance.³⁸

³⁶ *Id.*, 75 Fed. Reg. at 56181.

³⁷ *Id.*

³⁸ *Nondiscrimination on the Basis of Disability; Accessibility of Web Information and Services of State and Local Government Entities and Public Accommodations*, U.S. Department of Justice, (RIN 1190-AA61; 75 Fed. Reg. 43460, 43464 (July 26, 2010)). Available at: http://www.ada.gov/anprm2010/web%20anprm_2010.htm.

Chapter 1 - Overview

This requirement would have applied to both the City's and SAM's websites, although there may have been minor differences in how this obligation is imposed and whether a particular format is required.

In 2017, the DOJ formally announced “the withdrawal of four previously announced Advance Notices of Proposed Rulemaking (ANPRMs) pertaining to title II and title III of the Americans with Disabilities Act (ADA): (1) Nondiscrimination on the Basis of Disability; Accessibility of Web Information and Services of Public Accommodations (RIN 1190–AA61); (2) Nondiscrimination on the Basis of Disability in State and Local Government Services; Next Generation 9–1–1 (RIN 1190–AA62); (3) Nondiscrimination on the Basis of Disability by State and Local Governments and Places of Public Accommodation; Equipment and Furniture (RIN 1190–AA64); and (4) Nondiscrimination on the Basis of Disability: Accessibility of Web Information and Services of State and Local Government (RIN 1190–AA65).”³⁹ While these are now withdrawn, we believe they remain instructive of the future direction of regulation.

Additionally, as the DOT observed in a 2011 regulatory filing, transit providers' primary obligations are to DOT, not DOJ regulations. The DOT has deferred instituting a general regulatory requirement on web accessibility. Nevertheless, the DOT observed that “under existing rules a transportation entity has an obligation to provide effective communication to

³⁹ 28 C.F.R. §§ 35 & 36; 82 FR 60932 (Dec. 26, 2017), Nondiscrimination on the Basis of Disability; Notice of Withdrawal of Four Previously Announced Rulemaking Actions. Available at: <https://www.federalregister.gov/documents/2017/12/26/2017-27510/nondiscrimination-on-the-basis-of-disability-notice-of-withdrawal-of-four-previously-announced>.

Chapter 1 - Overview

persons with disabilities.”⁴⁰ This may include providing an accessible website or, if information is provided on an inaccessible site, then to provide the information through other means.

While there are not required website standards, the Web Accessibility Initiative (WAI) of the World Wide Web Consortium (W3C®) has created recognized voluntary international guidelines for Web accessibility. These guidelines, set out in the Web Content Accessibility Guidelines (WCAG), detail how to make Web content accessible to individuals with disabilities. The most recent and updated version of the WCAG, the WCAG 2.1, was published in June 2018 and is available at <https://www.w3.org/TR/WCAG21/>. “Following these guidelines will make content more accessible to a wider range of people with disabilities, including accommodations for blindness and low vision, deafness and hearing loss, limited movement, speech disabilities, photosensitivity, and combinations of these, and some accommodation for learning disabilities and cognitive limitations; but will not address every user need for people with these disabilities.”⁴¹

DOJ adoption of a required standard in the future is likely. Use of WCAG 2.1 and subsequent updates, however, will improve accessibility and enhance conformance with future standards.

B. Federal Enforcement

⁴⁰ *Transportation for Individuals with Disabilities at Intercity, Commuter, and High Speed Passenger Railroad Station Platforms; Miscellaneous Amendments*, U.S. Department of Transportation, RIN 2105–AD54. 76 Fed. Reg. 57924, 57931-57932 (amending 49 CFR Parts 37 and 38) (Sept. 19, 2011).

⁴¹ Web Content Accessibility Guidelines (WCAG) 2.1, June 5, 2018. Available at <https://www.w3.org/TR/WCAG21/>.

Chapter 1 - Overview

ADA title II is enforced through a variety of avenues, primarily by: (1) litigation brought by the United States Department of Justice (DOJ), and by private actors such as individual plaintiffs, civic access and non-profit groups, for example, Disability Rights South Dakota as a non-profit legal services agency (formerly as Protection & Advocacy Organizations),⁴² and (2) administrative enforcement by designated funding agencies, such as the U.S. Department of Transportation (DOT) and the Federal Highway Administration (FHWA).

The DOJ has ultimate responsibility for enforcement of the ADA and shares enforcement with relevant federal agencies. The DOJ receives and reviews thousands of complaints per year.⁴³ Enforcement may result in withdrawal of federal funding, court-ordered modifications, and settlements. Based on past experience, one would expect more comprehensive enforcement under the incoming Biden Administration.

The DOJ has for years supported an initiative known as Project Civic Access, which the DOJ describes as a coordinated program to ensure that cities “comply with the ADA by eliminating physical and communication barriers that prevent people with disabilities from participating fully in community life.”⁴⁴ Under the program, the DOJ has brought legal actions and negotiated scores of judicially enforced settlements (often called consent decrees) with

⁴² See Disability Rights South Dakota, <https://drsdlaw.org/>.

⁴³ See *Agency Information Collection Activities Under Review; Title II of the Americans with Disabilities Act of 1990/Section 504 of the Rehabilitation Act of 1973 Discrimination Complaint Form*, OMB Number 1190-0009. Available at: <https://www.govinfo.gov/content/pkg/FR-2012-01-09/pdf/2012-92.pdf>.

⁴⁴ United States Department of Justice, Project Civic Access web page, available at: <http://www.ada.gov/civicac.htm>. See <https://www.ada.gov/civicac.htm#SD> (Project Access settlements in South Dakota for Butte County, South Dakota 7/31/01; Minnehaha County, South Dakota 8/05/04; Pennington County, South Dakota 6/1/15; Rapid City, South Dakota 3/2/15).

localities. These resolutions cover a range of issues and frequently involve most programs and departments of the municipality at issue.

For example, a 2011 settlement regarding Des Moines, Iowa, included effective communications with government services generally, and emergency services, in particular, sidewalk accessibility, web accessibility, changes to program access, and modifications to many buildings constructed or modified after the ADA.⁴⁵ Other actions include accessibility issues at programs for victims of domestic violence, emergency shelters, and polling places. In addition, the DOJ in these settlements explicitly requires public entities to make their web pages accessible and advise its employees and third-parties of means and requirements to do so.⁴⁶

Some actions brought by private groups to enforce the ADA result in substantial verdicts or settlements. For instance, in a 2009 suit against the California Department of Transportation (CalTrans), plaintiffs obtained a settlement that requires CalTrans expend \$1.1 billion over 30 years for making sidewalks and other facilities accessible.⁴⁷ Similarly, in a 2002 suit against the City of New York, plaintiffs obtained a settlement agreement requiring that city dedicate \$218 million over an eight-year period to complete installation of curb ramps throughout the city.

However, when the City failed to comply adequately with the settlement, and completion

⁴⁵ See Settlement Agreement, *United States v. City of Des Moines, IA, and City of City of Des Moines, IA, Public Library*. No. DJ 204-28-72 (Signed March 2, 2011). Available at https://www.ada.gov/des_moines_pca/des_moines_pca_sa.htm.

⁴⁶ See, e.g. Settlement Agreement, *United States v. City of Trinidad, CO*. No. DJ # 204-13-317 (signed Feb. 7, 2018).) Available at https://www.ada.gov/trinidad_pca_sa.html.

⁴⁷ Settlement Agreement, *Californians for Disability Rights, Inc. ("CDR"), California Council of the Blind ("CCB"), Ben Rockwell and Dmitri Belser v. California Department of Transportation ("Caltrans") and Will Kempton*, No. C-06-5125 SBA (N.D. CA., dated Dec. 21, 2009). Available at: https://dralegal.org/wp-content/uploads/2012/09/settlementagreement_3.pdf.

would extend to as long as twenty-five years, advocates brought a new action and achieved anew settlement that would address simple curb ramps within three years, all curb ramps within eight years, and with the progress to be overseen by a court-appointed monitor.⁴⁸ These settlements typically require that cities produce amended ADA transition plans to establish an effective written plan to fully deploy curb ramps. Both settlements apply to new and existing sidewalks.

III. Guiding Principles

Access to governmental services, transportation and others aspects of participation in community life need not be viewed only in terms of minimal compliance with the ADA and its implementing regulations.⁴⁹ Clearly, the ADA and related laws form the proper and required foundation for beginning analysis of access to City transportation, civic, recreational and other aspects of society. But too often, analysis of these issues is driven to address the floor or minimal compliance with the law, when a broader view of compliance and access is not only more effective and efficient, but also more cost-effective in the long term.⁵⁰

Consequently, our guiding principles for review in this project include:

- Active and meaningful stakeholder participation, with public and private partners;

⁴⁸ See Court Report Confirms Dismal State of Sidewalks for Disabled New Yorkers, and Settlement Agreement. Available at <https://dralegal.org/press/court-report-confirms-dismal-state-sidewalks-disabled-new-yorkers/>. *Center for Independence of the Disabled New York (CIDNY), et al. v. City of New York, et al.*, Civ. 14 CV 5884 (S.D.N.Y. Mar. 13, 2019). Available at <https://www.nycpedramps.info/sites/default/files/2019-07/Pedestrian%20Ramp%20Settlement%20Agreement--Final%20Approved%207-23-2019.pdf>.

⁴⁹ See generally ADA Title II, 42 U.S.C. §§ 12131-12149, and Section 504 of the Rehabilitation Act of 1973 ("section 504"), 29 U.S.C. § 794.

⁵⁰ See, e.g., 2010 DOJ ADA Regulations, 56164 Fed. Reg. at 56168 (regulatory impact assessment of 2010 accessibility regulations demonstrate access improvements increase social resources "and thus represent a public good because monetized benefits exceed monetized costs"). See also Peter Blanck, Eve Hill, Charles Siegal, & Michael Waterstone, *DISABILITY CIVIL RIGHTS LAW AND POLICY*, Second Edition, Thomson/West Publishers (2009).

Chapter 1 - Overview

- Review of challenges (e.g., complaints) and opportunities (enhancements that make Sioux Falls a great place to live and work for all);
- Development of information and systems (written and online) to effectively mitigate and resolve disputes, with a person-centered approach;
- Pursuit of generic and disability-specific meaningful outcomes that are capable of success, which have broad reach;
- Recommendations that are fiscally responsible and effective;
- Recommendations that are relevant to and complement and enhance local and regional civic and social participation, culture, economy, and the environment (e.g., sustainability and public health).

One important part of our analysis is to assess the degree to which the City's transit system works effectively under various conditions, such as inclement weather and capacity in real time for Sioux Falls users with varied disabilities across the life span. Our analysis was informed by discussions with key stakeholders, including staff at all levels and interested non-governmental organizations, town hall meetings, review of documents, and active observation and analysis of the systems' operations past, present and expected in the future, in terms of projected growth and need, and given use of new technologies and cost-effective systems (See Method, below at 2-10.)

A. Universal Design

As another guiding principle of our approach in this report, where appropriate we have suggested to the City and SAM they may effectively apply principles of "universal design" (UD) in their programs and services. Universal design is "the design of products, environments, programmes and services to be usable by all people, to the greatest extent possible, without

the need for adaptation or specialized design. ‘Universal design’ shall not exclude assistive devices for particular groups of persons with disabilities where this is needed.”⁵¹

Universal design is not only intended to make facilities, products, services, and technologies accessible to people with disabilities, but more broadly to find solutions for particular locations and uses that are effective for all people. Universal design approaches to bus transportation, for instance, include lowered bus boarding heights, wide treads for stability, good handrails, color contrasts for all handrails and step edges, plentiful stanchions, seats that are large enough for people to use comfortably, and stop request mechanisms that may be easily reached by seated passengers.⁵²

Accessible bus stops are a part of a UD approach to public transit, in that they increase accessibility for all, while making boarding and disembarking for all riders efficient. Curb ramps not only enable people with disabilities to navigate sidewalks, but also make sidewalks more useful for others such as parents with strollers, and pedestrians with shopping carts.

IV. Review Approach

A. Method

By applying the guiding principles and methods for review stated in this report, our aim is to enhance the City’s capability to improve the accessibility and livability of the City overall, and in an ongoing and cost-effective manner. We apply this method to each of the City’s programs, services and activities in the subsequent chapters as assigned by the City.

⁵¹ United Nations Convention on the Rights of Persons with Disabilities, Art. 2.

⁵² See *Universal design for local transport – some European experiences*, International Centre for Accessible Transportation. Available at: <http://www.icat-ciat.org/Text%20Universal%20design.htm>.

Chapter 1 - Overview

To assist the City of Sioux Falls and SAM to accomplish the stated goals of this review, for people with disabilities and for all other stakeholders, we conducted and attempted to facilitate the following activities (in-person and via telephone/electronic means):

- 1) collection and review of a wide range of relevant documents;
- 2) interviews and working discussions with City and SAM staff;
- 3) engage the public at town halls and open meetings with groups composed of and serving people with disabilities;
- 4) discuss legal minimums and best practices transcending ADA compliance with emphasis on UD approaches in Sioux Falls and from similar localities and the Federal government;
- 5) request input from the public by publicizing the review to media outlets including newspapers and local broadcast television news;
- 6) develop this report by documenting its analyses, findings and recommendations, and presenting it for review and comment by relevant stakeholders; and,
- 7) enable the City and local stakeholders to update and enhance the implementation of ADA-related activities, in this “living” document.

Our current 2021 review was conducted online and by phone due to the Covid-19 pandemic, but also was informed by our prior work with the City in person between 2011 and 2015. For reference, the systematic phases of our review include:

“Phase 1”: comment on and suggest in writing recommendations and updates to the City’s existing draft 2015 Americans with Disabilities Act (ADA) Transition Plan in regard to access to City activities and programs by individuals with disabilities and other stakeholders such as family members, and visitors to the City (hereinafter the “Phase 1 Draft Initial Report”);

Chapter 1 - Overview

“Phase 2”: research and develop an evaluation of existing City facilities and program areas as identified and agreed in Phase 1 with the City, from the perspective of the ADA, and based on relevant updated information and materials provided by the City and derived from interviews (in-person, telephone, web-based surveys) with City key personnel, to draft an initial updated ADA Transition Plan, which was submitted to the City for comment in 2020;

“Phase 3”: identify existing and possible access barriers to City facilities and programs, by in-person, telephone, web-survey or other engagement with the City and its relevant personnel, local community stakeholders, and the local disability community via one Town Hall Meeting and open forum in the City (held electronically due to the pandemic), that was duly organized and publicized prior by the City, and incorporate such information and commentary into the draft ADA Transition Plan for review and comment by the City;

“Phase 4”: based on Phases one, two, and three above, provide final suggestions to the City in regard to means to update the existing ADA transition plan, with the goal that the City may develop ongoing and appropriate barrier removal, access, and universal design in appropriate, timely and cost effective means; and, which may include at the City’s discretion the Consultant’s in-person or electronic presentation to the City Council, Mayor’s Office, and/or City Service and Department lead personnel.

As discussed below, the City has engaged in a number of significant architectural self-evaluations previously and made changes to City buildings. Over the past 30 years, the City has made numerous physical changes to its buildings to improve accessibility. We have not as part

of this review duplicated nor evaluated these prior reviews, detailed measurements, and other evaluations. Some of these efforts are referenced in this report. Instead, as the City has already made these changes, we focused our review on current, overall program access.

V. Sioux Falls Area

A. Population, Geography, Economy & Climate

The City of Sioux Falls, South Dakota, had a population of 153,888 as of the 2010 census,⁵³ and an estimated population of 183,793 in 2019.⁵⁴ The City has a diverse service-oriented economy and is an important location for financial services, health care, and retail trade.

The City is an important regional hub for these activities. Health care, shopping and convention space draw visitors from the region. These include the Empire Mall, hospitals, convention center and new event center, museums, and cultural attractions. Sioux Falls maintains manufacturing and heavier industries, particularly food processing. The City has a number of public and private universities.

B. Climate Considerations

The climate is characterized by large seasonal temperature differences, with warm to hot (and often humid) summers and cold (sometimes severely cold) winters. From mid-January to mid-July, average highs range from 26 to 84°F, and average lows range from 7 to 62°F.⁵⁵

⁵³ 2010 Census. Available at: <https://www.census.gov/programs-surveys/decennial-census/decade.html>.

⁵⁴ See <https://www.census.gov/quickfacts/siouxfallscitysouthdakota>.

⁵⁵ *Average Weather for Sioux Falls, SD – Temperature and Precipitation*, The Weather Channel. Available at: <http://www.weather.com/weather/wxclimatology/monthly/graph/USSD0315>. Retrieved September 21, 2011 (see website for updates).

Total precipitation, with rain concentrated in the warmer months, shows a median of approximately three inches per month between May and August. Periods of high winds and thunderstorms are common. Total annual snowfall averaged 40.6 inches between the years 1969-70 and 2008-09, with a high of 75 inches in 1983-84.⁵⁶ As discussed below, temperature extremes and precipitation, both snow and rain, impact people with disabilities more significantly than others.

C. Governance

The City is governed by a mayor and city council. The administration is divided into 12 departments, each grouped around particular government programs, activities and services. Certain activities and services involve multiple departments.

The City has an ADA Coordinator whose portfolio includes responsibilities related to SAM as well as all other aspects of government.⁵⁷ The City ADA Coordinator has responsibility to address issues related to disability, including coordinating compliance efforts, overseeing grievance procedures, and development of the City's ADA Transition Plan. The ADA Coordinator ensures the City operates under rules governing nondiscrimination on the basis of disability in local government services, including investigation of complaints arising out of allegations that local government has failed to comply with the ADA.

⁵⁶ Based on data from the National Oceanic and Atmospheric Administration (NOAA), available at: <https://www.weather.gov/fsd/monthlysnow>.

⁵⁷ See ADA Coordinator description on the City's website, available at: <https://www.siouxfalls.org/city-attorney/relations/ada-coordinator>.

The ADA Coordinator is a liaison for the City to outside disability organizations. The Disability Awareness and Accessibility Review Board is an extension of the Human Relations Commission and works toward improved access for people with disabilities. It acts as an advisory body to the City ADA Coordinator. It includes people with disabilities.⁵⁸ It was formed in 2020, combining the Disability Awareness Commission and the Accessibility Review Board.

D. Prior Transition Plans and Self-Evaluations

Since the passage of the Americans with Disabilities Act (ADA), the City of Sioux Falls made efforts to formally begin and continue the process of compliance with the ADA. Prior to the enactment of the ADA, the City had conducted self-evaluations of programs, policies, and facility accessibility, and had taken steps to achieve full program accessibility in order to comply with the requirements of the Rehabilitation Act of 1973. A thorough review of Section 504 self-evaluations was conducted, and reevaluations of programs initiated, which included the conducting of physical surveys, evaluation of services and programs, public meetings with advocacy and citizen groups representing people with disabilities, and onsite visitations by representatives of the group then-labeled the Mayor's Committee for Citizens with Disabilities.

A review of City policies and procedures was conducted on a department-by-department basis, and policies and procedures regarding ADA responsibilities and compliance were adopted. An implementation program was initiated to achieve necessary barrier removal and improve accessibility to City programs as required under title II of the ADA. The City

⁵⁸ The City has had two boards addressing disability: Disability Awareness Commission and the ADA Accessibility Review Board. At the time of this writing, these are being combined into the Disability Awareness and Accessibility Review Board, and the City is currently recruiting for this new board.

Chapter 1 - Overview

conducted subsequent self-evaluations and updated its transition plans in 1998-1999, and again with a process that stretched from 2001 to 2003, as well as a draft review in 2015. The City has engaged in continual activities to assess and improve City accessibility in accord with these prior reviews.⁵⁹

⁵⁹ One study in 2014, based on Census data, ranked Sioux Falls fifteenth amongst one-hundred fifty municipalities on factors related to disability, including economic cost of living, quality of life, and health care accessibility (by number of doctors compared to population) and quality. See Richie Bernardo, *2014's Best & Worst Cities for People with Disabilities*, WalletHub.Com. Available at: <http://wallethub.com/edu/best-worst-cities-for-people-with-disabilities/7164/>. In 2019, this study found Sioux Falls ranked at 41, and its health care ranking at 8. In 2021, this site has dropped Sioux Falls to 81 out of 182. Whether this says more about the ranking site or changes in Sioux Falls is unclear.

Chapter 2 - Transportation

I. Introduction

In this chapter focused on transportation, we analyze Sioux Area Metro's and the City's policies and practices as they affect people with disabilities as well as the general public and the City. We attempt to determine where the system is working well, and where there are challenges to be addressed. Finally, we recommend changes to improve the functioning and accessibility of programs, services, and activities undertaken by the City and SAM.

Transportation enables us all to work, choose where to live, pursue an education, access health care, worship, shop, and participate in social and recreational activities. The right to travel is a core element of our democracy.⁶⁰ In discussing the ADA, the House Committee on Education and Labor stated transportation is "the linchpin which enables people with disabilities to be integrated and mainstreamed into society."⁶¹ Without accessible transportation, people with disabilities are confined to home, unable to go to work, attend school, attend religious services, and meaningfully participate in other aspects of public life.⁶²

⁶⁰ The Supreme Court held the right to interstate travel is a constitutional right found in the Equal Protection Clause. *See United States v. Guest*, 383 U.S. 745 (1966); *Shapiro v. Thompson*, 394 U.S. 618 (1969); *Saenz v. Roe*, 526 U.S. 489 (1999). While the Supreme Court has not explicitly found a constitutional right to *intrastate* travel, many argue "a fundamental right of intrastate travel exists, and many courts have embraced *Shapiro* and its progeny as holding that a right to intrastate travel exists." Andrew C. Porter, *Toward a Constitutional Analysis of the Right to Intrastate Travel*, 86 Nw. U. L. Rev. 820, 829 (1991-1992). In passing the ADA, Congress notes past discrimination against people with disabilities in transportation, and invokes the Fourteenth Amendment to the Constitution to ensure due process and equal protection for people with disabilities. *See* 42 U.S.C. § 12101.

⁶¹ H.R. REP. No. 101-485, at 37 (1990), reprinted in 1990 U.S.C.C.A.N. 303, 319.

⁶² *See* 42 U.S.C. § 12101(a)(3).

Chapter 2 – Transportation

An efficient, accessible public transportation system ensures that all people with diverse needs and backgrounds in a community share equally in the benefits of the system. When well designed, a universally designed (UD) public transportation system further benefits all stakeholders, regardless of background characteristics such as disability or age. In the absence of access to transportation “individuals may choose to leave the workforce unnecessarily - when able to perform the essential functions of the job but unable to get to and from work reliably. This robs companies of valuable employees. As the workforce ages, and with it the incidence of disability grows, if transportation systems are not improved the problem will become catastrophic to business.”⁶³ Accessibility benefits not only riders with disabilities, but also businesses, government, and society generally.

Accessible public transportation furthers local economic development, regional integration generally, and the interest of the City of Sioux Falls in being a livable, vibrant, and attractive destination for all. To accomplish these goals, the City’s transit system should be planned and integrated with other public services and programs to address the needs of various stakeholders, and in ways that make environmental, social, civic and economic sense.

Effective planning and implementation of a local public transit system is best conceived as a core civic activity with meaningful engagement by citizens of the community. As such, effective transit systems reflect a partnership of activities with local stakeholders and citizens. The long-term success, sustainability, and compliance and transcendence with legal regulations

⁶³ Written testimony of Jill Houghton, US Business Leadership Network, to U.S. Senate, Health, Education, Labor and Pensions Committee, at 4 (Nov. 17, 2011); available at: <http://help.senate.gov/imo/media/doc/Houghton.pdf>.

such as the ADA, are enhanced by active and meaningful participation by all. The ADA recognizes this, and explicitly requires community participation in the development of public transportation plans.⁶⁴

A. Universal Design

As mentioned, universal design is not only intended to make facilities, products, services, and technologies accessible to people with disabilities, but also broadly intended to find solutions for particular locations and uses that are effective for all people. Universal design approaches to bus transportation include lowered bus boarding heights, wide treads for stability, good handrails, color contrasts for all handrails and step edges, plentiful stanchions, seats that are large enough for people to use comfortably, and stop request mechanisms that may be easily reached by seated passengers.⁶⁵ Accessible bus stops are a part of a UD approach to public transit, in that they increase accessibility, while making boarding and disembarking for all efficient and safe.

II. Federal Disability Law Regarding Transportation

A. Federal Requirements

As noted, ADA title II prohibits public entities, such as the City and SAM, from discriminating against people with disabilities. Public entities must ensure that no qualified individual with a disability,⁶⁶ on the basis of disability, is excluded from participation in or

⁶⁴ Public participation is required for development of Paratransit plans, 49 C.F.R. §37.137, and waiver plans when fixed route systems or new construction are not accessible.

⁶⁵ See *Universal design for local transport – some European experiences*, International Centre for Accessible Transportation. Available at: <http://www.icat-ciat.org/Text%20Universal%20design.htm>.

⁶⁶ See Footnote 15, *supra* at I-1.

Chapter 2 – Transportation

denied equal benefits of the services, programs, and activities of a public entity, or faces discrimination by any such an entity, 42 U.S.C. § 12132.⁶⁷ Beyond the ADA’s general and program accessibility requirements, the statute and its implementing regulations provide requirements addressing transportation access.

The City and SAM are responsible for these access requirements, even when their operation is contracted to an outside vendor such as First Transit, Inc.⁶⁸ Examples of discrimination in violation of title II’s transportation provisions include the failure to maintain bus lifts in operable order and to meet required capacity in the provision of Paratransit services.

Title II and the regulations set out by the DOT governing public transportation⁶⁹ require SAM, for instance, to:

- operate fixed route buses with wheelchair lifts and other accessibility features,
- maintain the wheelchair lifts and other accessibility features on its buses (for example, signage and notifications) in operative condition,
- maintain accessibility of its bus stops, including mechanical defects and snow removal,
- promptly repair wheelchair lifts and other accessibility features if they are damaged or out of order,
- establish a system of regular and frequent maintenance checks of wheelchair lifts and remove a vehicle from service if the lift is inoperative, with some exceptions,
- provide alternative transportation when the lift doesn't work and the next accessible bus is more than 30 minutes away,

⁶⁷ See Footnote 16, *supra* at I-1.

⁶⁸ 28 C.F.R. § 35.130 (b).

⁶⁹ 49 C.F.R. Part 27 (DOT § 504 Regulations) are the regulations that address requirements for transportation entities receiving Federal financial assistance and 49 C.F.R. Part 37 (DOT ADA Regulations) are regulations that address requirements for transportation entities under the ADA. The Secretary of Transportation has the authority to issue final regulations implementing Part B of Title II, including regulations governing the provision of fixed route and Paratransit services. See 42 U.S.C. §§ 12143(b), 12149, 12164.

Chapter 2 – Transportation

- train personnel so they properly assist and treat individuals with disabilities in a careful, respectful and courteous way and operate equipment safely,
- use securement systems to secure wheelchairs on the bus,
- designate a responsible employee to coordinate efforts regarding accessibility, and,
- adopt meaningful and accessible complaint procedures.

A failure to comply with these requirements constitutes a violation of the ADA.

SAM must also provide Paratransit, or other special services, to eligible individuals with disabilities comparable to the level of service provided to individuals without disabilities who use the fixed route system.⁷⁰ Paratransit is defined by the DOT regulations as a “comparable transportation service required by the ADA for individuals with disabilities who are unable to use fixed route transportation systems.”⁷¹

DOT ADA regulations require Paratransit to meet six basic service criteria:⁷²

- *Service Area* - service must be provided in the same areas as the fixed route service (including origins and destinations within corridors of three-quarters of mile on each side of, and at each end of, the fixed route);
- *Response time* - service must be available to those making reservations the previous day;
- *Fares* - fare must be no more than twice that of the fixed route service;
- *Trip purpose restrictions* - providers shall not impose restrictions or priorities based on trip purpose;
- *Hours and days of service* - Paratransit service shall be available throughout the same hours and days as the entity's fixed route service;

⁷⁰ ADA, 42 U.S.C. § 12143; DOT ADA Regulations, 49 C.F.R. § 37.121.

⁷¹ DOT ADA Regulations, 49 C.F.R. § 37.3.

⁷² DOT ADA Regulations, 49 C.F.R. § 37.131.

Chapter 2 – Transportation

- *Capacity constraints* - providers shall not limit the availability of Paratransit service to ADA Paratransit eligible individuals by restrictions on the number of trips an individual may take, waiting lists, or other operational pattern that limits availability.⁷³

These criteria are to ensure service is complementary and comparable to the fixed route system.

Access to public sidewalks is part of the ADA’s statutory text and implementing regulations. The ADA’s general requirements, along with its regulations, for instance, require that sidewalks and other aspects of public rights-of-way to transit are accessible. Public rights-of-way⁷⁴ and facilities are required to be accessible to persons with disabilities under ADA title II⁷⁵ as well as under Section 504, as the City receives Federal funding in support of road building and other projects.⁷⁶ These laws work in tandem and the regulations applicable to ADA and Section 504 by statute are consistent.⁷⁷

⁷³ Note – A change governing capacity was made in September, 2011. Under the new rule, if one leg of a multi-leg Paratransit trip is denied or cancelled by the provider, each leg of the trip is to count as a denial. See *Transportation for Individuals with Disabilities at Intercity, Commuter, and High Speed Passenger Railroad Station Platforms; Miscellaneous Amendments*, U.S. Department of Transportation, RIN 2105–AD54. 76 Fed. Reg. 57924, 57931-57932 (amending 49 CFR Parts 37 and 38) (Sept. 19, 2011).

⁷⁴ “Public rights-of-way” are not defined under the ADA or DOJ regulations. However, proposed regulations governing public rights of way define them to mean “public land or property, usually in interconnected corridors, that is acquired for or dedicated to transportation purposes.” See R105.5, *Americans With Disabilities Act (ADA) Accessibility Guidelines for Buildings and Facilities: Public Rights-of-Way*, 76 Fed. Reg. 44664, 44688 (Published July 26, 2011). Available at: <http://www.gpo.gov/fdsys/pkg/FR-2011-07-26/pdf/2011-17721.pdf>. The guidelines reference public streets, sidewalks, and overpasses, and address pedestrian equipment on such places including benches, bus stop shelters, signals, and the like.

⁷⁵ ADA, 42 U.S.C. §§ 12131-12164.

⁷⁶ Section 504, 29 U.S.C. § 794.

⁷⁷ ADA, 42 USC § 12134.

Chapter 2 – Transportation

Access issues related to City sidewalks are detailed in another chapter of this report.

However, because sidewalks and the City’s bus transportation are integrally related, we address them here preliminarily.

The important relation between transit and sidewalk access was emphasized in the U.S. Court of Appeals for the Fifth Circuit’s 2011 full court (i.e., *en banc*) decision in *Frame v. City of Arlington*. The Court observed:

... in clarifying the requirements of Title II in the unique context of “designated public transportation services” (e.g., regular rail and bus services), Congress expressly provided that § 12132 requires new and altered “facilities” to be accessible. Although Congress did not define “facilities,” the relevant Department of Transportation (DOT) regulations define the term to include, inter alia, “roads, walks, passageways, [and] parking lots.”

This interrelation also was emphasized in the ADA House report, which noted “local and state governments are required to provide curb cuts on public streets. The employment, transportation, and public accommodation sections of this Act would be meaningless if people who use wheelchairs were not afforded the opportunity to travel on and between streets.”⁷⁹

While generally requiring “program access,” the ADA and its implementing regulations single out installation of curbs cuts to existing sidewalks to be implemented as part of the required original ADA transition plans.⁸⁰ Thus, while we treat sidewalks in this ADA Transition

⁷⁸ *Frame v. City of Arlington*, 657 F.3d 215, at 228-29 (5th Cir., *en banc*, Sept. 15, 2011) (cert. den’d Feb. 21, 2012) (internal citations omitted). Available at: <http://www.ca5.uscourts.gov/opinions/pub/08/08-10630-CV3.wpd.pdf>.

⁷⁹ H.R. REP. No. 101-485(1), pt. 2, at 84 (1990), reprinted in 1990 U.S.C.C.A.N. 303, 367.

⁸⁰ See interpretation of 28 C. F. R. 35.151(d)(2) in U.S. DOJ 1991 Section By Section Analysis, 28 C. F. R. 35, p. 202-203 (transition plan must include schedule for curb cuts at existing crosswalks).

Chapter 2 – Transportation

Report in a separate chapter per the City’s instructions to us, the issues surrounding the City’s bus / Paratransit system and its sidewalks, and other paths of access, are inextricably linked.

B. Federal Enforcement

ADA title II is enforced through a variety of avenues, primarily by: (1) litigation brought by the United States Department of Justice (DOJ), and by private actors such as individual plaintiffs, civic access and non-profit groups, for example, Disability Rights South Dakota as a non-profit legal services agency (formerly as Protection & Advocacy Organizations),⁸¹ and (2) administrative enforcement by designated funding agencies, such as the U.S. Department of Transportation (DOT) and the Federal Highway Administration (FHWA).

The DOJ has ultimate responsibility for enforcement of the ADA and shares enforcement with these agencies. The DOJ receives and reviews thousands of complaints per year.⁸² It is unclear how many additional complaints are addressed solely by the DOT. Enforcement may result in withdrawal of federal funding, court-ordered modifications, and settlements.

The DOJ’s Project Civic Access has addressed a number of cases focusing on public transportation. These include actions addressing bus lift maintenance, Paratransit capacity, and sidewalk access construction and maintenance.⁸³ For example, in a joint collaboration with the Federal Transportation Administration (FTA), in 2010 the DOJ entered a settlement with the

⁸¹ See Disability Rights South Dakota, <https://drsdlaw.org/>.

⁸² See *Agency Information Collection Activities under Review; Title II of the Americans with Disabilities Act of 1990/Section 504 of the Rehabilitation Act of 1973 Discrimination Complaint Form*, OMB Number 1190-0009. Available at: <https://www.govinfo.gov/content/pkg/FR-2012-01-09/pdf/2012-92.pdf>.

⁸³ See agreements at the Project Civic Access web site, *supra*.

Chapter 2 – Transportation

Jackson, Mississippi, Public Transportation System, in which the DOJ had accused the City's transportation system of:

(1) failure to maintain, promptly repair, and keep vehicle lifts in operative condition, in violation of 49 C.F.R. §§ 37.161(a) and (b); 163(b), (d) and (e); and 28 C.F.R. § 35.133;

(2) failure to promptly provide alternative transportation to individuals with disabilities in any case in which a vehicle is operating on a fixed route with an inoperative lift and the headway to the next accessible vehicle on the route exceeds thirty (30) minutes, in violation of 49 C.F.R. § 37.163(f);

(3) failure to train personnel to proficiency so they operate vehicles and equipment safely and properly, assist and treat individuals with disabilities who use the service in a respectful and courteous way, in violation of 49 C.F.R. § 37.173;

(4) failure to provide Paratransit services to individuals with disabilities “that are sufficient to provide to such individuals a level of service . . . which is comparable to the level of designated public transportation services provided to individuals without disabilities” who use defendants’ fixed route system, in violation of 42 U.S.C. § 12143(a) and 49 C.F.R. § 37.121(a);

(5) failure to schedule and provide Paratransit service to any ADA Paratransit eligible person at any requested time on a particular day in response to a request for service made the previous day, in violation of 49 C.F.R. § 37.131(b);

(6) failure to plan to meet Paratransit demand, in violation of 49 C.F.R. § 37.131(b); and

(7) capacity constraints significantly limiting availability of service to ADA Paratransit eligible persons, including substantial numbers of trip denials, missed trips, significantly untimely pickups for initial or return trips, trips with excessive trip length, and telephone reservation capacity constraints, including busy signals and long telephone hold times, in violation of 49 C.F.R. § 37.131(f)(3).⁸⁴

⁸⁴ Consent Decree, *Crawford, et al., & the United States v. City of Jackson, Mississippi, and the City of Jackson Public Transportation System (JATRAN)*, No. 3:08-cv-586-TSL-FKB (S.D. Miss., March 30, 2010). Available at: http://www.ada.gov/jackson_transit.htm.

The settlement, as with others DOJ has entered, is comprehensive, addresses these and other areas, and includes on-going reporting to and monitoring by the DOJ.

III. Review Approach

A. Method

By applying the guiding principles and methods for review stated in this report, our aim is to enhance the City’s capability to improve the accessibility of its public transportation system overall, and in a safe and cost-effective manner.

Our analysis was informed by discussions with key stakeholders, including staff at all levels and interested non-governmental organizations, town hall meetings, review of documents, and active observation and analysis of the systems’ operations past, present and expected in the future, in terms of projected growth and need, and given use of new technologies and cost-effective systems.

One important part of our analysis is to assess the degree to which the City’s transit system works effectively under various conditions such as inclement weather and capacity in real time for Sioux Falls users with varied disabilities.

B. Informational Sources and Meetings

The authors collected information related to the City and SAM by reviewing requested documents, and from meetings with key stakeholders.

1) Collected and reviewed documents, for example, including and related to:

- Sioux Area Metro prior transition and development plans;
- SAM 2011 Bus Stop Accessibility Review;

Chapter 2 – Transportation

- Sioux Falls prior transition plans;
 - Complaints and responses;
 - Public hearings;
 - City and route maps;
 - Sioux Falls area weather information;
 - City ADA board minutes and supporting materials;
 - Comparisons to relevant city peers;
 - City of Sioux Falls Sidewalk Policies and ADA Title II Curb Ramp Transition Plan, and 2018 Public Rights of Way Transition Plan;
 - Information on current buses and vans, and capital plans;
 - Census, density information;
 - Access of City website and bus technology;
- 2) Sought public input via the City’s website, outreach through the press, including interviews and on the City’s television channel, and information directed to users through other avenues, including local organizations and users on buses.
 - 3) Organized interviews of stakeholders, public meetings with groups of and representing people with disabilities, and town hall meetings.
 - 4) Toured City facilities, including The Bus Stop (TBS) and the Southwest Transfer Center (SWC), and representative bus stops with SAM personnel;
 - 5) Rode a City bus with SAM staff and a concerned rider to review particular locations of concern and experience typical procedures;
 - 6) Recommended that SAM audit the accessibility of its fixed route bus stops and develop a list outlining issues;
 - 7) Organized these findings into a report, which then was presented for review and comment by relevant stakeholders; and,
 - 8) Enable the City and local stakeholders to update and enhance the implementation of ADA-related activities.

IV. Sioux Falls Area Transportation Overview

A. Transportation Governance

The City of Sioux Falls acquired the local public transit system in 1979. The City owns the buses, buildings, and equipment, with the day-to-day operations contracted to a transit management company. First Transit, Inc. is the current provider.

Sioux Area Metro (SAM) provides two types of services: fixed-route service, and Paratransit service. First Transit has one employee who works full-time managing the City transit system. All other transit employees are employed by a subsidiary of First Transit, known as SuTran, Inc. All employees receive training on SAM’s policies and procedures related to disability. There is initial-hire training, and additional issues are discussed in monthly meetings.⁸⁵

SAM is a governmental entity, reporting to the City Department of Planning and Development Services. Other departments have responsibilities that overlap with transit. For example, SAM operates the buses themselves, but SAM interacts with City staff in the planning and engineering departments for the construction of new bus stops. The Street Division of Public Works has maintenance and cleaning responsibility for City streets and facilities, including sidewalks that affect access to the bus stops.⁸⁶

Maintenance of private sidewalks is the responsibility of the private property owner or person in possession, and failure to properly maintain sidewalks is enforced through the

⁸⁵ Meeting with Karen Walton (SAM General Manager) & Debra Gaikowski (City Planner for Transportation), Aug. 24, 2011. See also meeting notes to monthly SAM employee meetings.

⁸⁶ Bus Stop tour with Karen Walton (SAM General Manager) & Dennis Erckfritz (SAM Operations Manager), Aug. 24, 2011); meeting with Karen Walton (SAM General Manager) & Debra Gaikowski (City Planner for Transportation), Aug. 24, 2011.

Chapter 2 – Transportation

Community Development Department and Engineering Division of Public Works.⁸⁷ If a private owner or person in possession fails to maintain his sidewalks, the City may intervene and repair or plow the sidewalks at the landholder's expense.⁸⁸ Areas around bus stops thus require maintenance by different groups, with SAM responsible for the bus stop itself, bus bench contractors responsible for the area around the bench, and the public in possession for the sidewalks surrounding bus stops.

People with disabilities have several alternatives to address perceived issues and failures affecting their access to the City's transit system. Transit issues may be formally addressed to the City ADA Coordinator, the City Disability Awareness and Accessibility Review Board, or to the Public Transit Advisory Board (PTAB). Complaints lodged directly with SAM are addressed internally or may be referred. SAM maintenance issues are tasked to responsible SAM employees or referred to the relevant City department.⁸⁹

SAM is advised by a Public Transit Advisory Board (PTAB). Representatives from organizations representing people with disabilities are on the Board. PTAB holds monthly public meetings in an accessible space. The agenda for each meeting is printed in Braille, and sign

⁸⁷ Community Development handles sidewalk snow removal. Engineering handles sidewalk hazard inspection and repair and ADA compliance.

⁸⁸ *Id.* Revised Ordinances of Sioux Falls, SD, §§ 96.100 – 96.105 (concerning snow removal).

⁸⁹ Bus Stop tour with Karen Walton (SAM General Manager) & Dennis Erckfritz (SAM Operations Manager), Aug. 24, 2011); meeting with Karen Walton (SAM General Manager) & Debra Gaikowski (City Planner for Transportation), Aug. 24, 2011.

language interpreters are available upon request. SAM has produced several transit development plans.⁹⁰

B. Fixed Route Buses

In 2021, SAM operates 12 regular fixed routes. There are 26 fixed-route buses with 21 buses used during peak pull-out times. All buses are equipped with ADA compliant lifts and other access features, and have space for two wheelchairs.⁹¹ Lifts and other features are checked daily before buses enter service.⁹² The excess of buses relative to everyday demand allows for regular and emergent maintenance of the buses (and replacement if there are mechanical issues, including with the lifts). Buses are equipped with a speaker system and the drivers announce stops.⁹³

Buses operate in a hub and spoke manner. There are two hubs tied to the City’s transit system: The Bus Stop (TBS) and the Southwest Transfer Center (SWC). The Bus Stop was built in 1988. It is a 13-bay transfer station located in the center of downtown. The facility provides a heated, enclosed area for passengers waiting to board, along with public restrooms and covered access to all buses. The facility and its features, including the entrances, restrooms, information booth, and other features are accessible.⁹⁴ The bus loading bay areas are accessible

⁹⁰ *Sioux Falls Transit Development Plan, Oct. 28, 2016. Available at <https://www.siouxfalls.org/mayor/boards-commissions/public-transit-advisory-bd/transit-dev-plan>*

⁹¹ Bus Stop tour with Karen Walton (SAM General Manager) & Dennis Erckfritz (SAM Operations Manager), Aug. 24, 2011); *Sioux Falls Transit Development Plan, Oct. 28, 2016. Available at <https://www.siouxfalls.org/mayor/boards-commissions/public-transit-advisory-bd/transit-dev-plan>.*

⁹² *Id.*

⁹³ *Id.*

⁹⁴ The authors toured and inspected the Bus Stop and Southwest Transfer Center, August 23, 2011.

Chapter 2 – Transportation

for wheelchairs and contain embedded detectable warnings along the edge of the platform areas.⁹⁵

In 2005, the SWC, on Louise Avenue near the Empire Mall, was built as an additional 5-bay transfer station along with a park-n-ride providing 22 parking spaces. This is an unmanned, enclosed, heated facility for waiting passengers. The facility is ADA compliant.⁹⁶

There are approximately 400 bus stops in town, with approximately 60 shelters and 52 stops with benches.⁹⁷ The stops without shelters are generally located on sidewalks, although some are in less developed areas without sidewalks. Bus stops are designated by signs.

At the start of this review in 2011, SAM officials did not have a then current and comprehensive list of bus stops that were not accessible or otherwise had access limitations.⁹⁸ At the recommendation of the authors, SAM officials undertook an accessibility survey of all City bus stops.⁹⁹

For December 2011, a summation of the City bus access survey indicated the following:¹⁰⁰

Route	Number stops	Number inaccessible stops	% Inaccessible
Route 1	44	12	27.3%
Route 2	43	7	16.3%

⁹⁵ During a visit to The Bus Stop on August 23, 2011, the authors observed and reported weather damage to the curb ramps to the block on which The Bus Stop sits. (As of October 2014, the issue remained unresolved).

⁹⁶ The authors toured and inspected the Bus Stop and Southwest Transfer Center, August 23, 2011.

⁹⁷ Bus Stop tour with Karen Walton (SAM General Manager) & Dennis Erckfritz (SAM Operations Manager), Aug. 24, 2011); *Sioux Falls Transit Development Plan, 2011-2015*, at 4.

⁹⁸ Meeting with Karen Walton (SAM General Manager), Randy Hartman (SAM Assistant General Manager) & Debra Gaikowski (City Planner for Transportation), October 3, 2011; Bus tour with Randy Hartman (SAM Assistant General Manager), Dennis Erckfritz (SAM Operations Manager) and concerned rider, October 4, 2011.

⁹⁹ Requirements are found in the 2004 ADAAG at section 810. See Appendix 1.

¹⁰⁰ Source: SAM 2011 ADA Bus Stop reviews. Note that because some bus stops are located on more than one route, the total number of stops and inaccessible stops is approximate.

Chapter 2 – Transportation

Route	Number stops	Number inaccessible stops	% Inaccessible
Route 3	48	5	10.4%
Route 4	28	5	17.9%
Route 5	28	7	25.0%
Route 6	27	7	25.9%
Route 7	44	11	25.0%
Route 8	23	7	30.4%
Route 9	30	3	10.0%
Route 10	57	18	31.6%
Route 11	29	13	44.8%
Route 19	24	11	45.8%
Total	425	106	24.9%

Preliminary review of this 2011 survey showed that approximately 25 percent of all bus stops on the fixed routes were rated as not fully accessible. Reasons for their inaccessibility included: (1) they were located in areas without sidewalks, bus pads, and other safe platforms for wheelchairs, (2) the sidewalk at which the bus stop was located did not have wheelchair cut outs or the sidewalk or cut out was damaged due to weather or other issues, and/or (3) the sidewalks were too narrow to allow the lift to deploy and provide space for a wheelchair to exit.¹⁰¹

To mitigate these flagged conditions, as an immediate step, SAM instructed City bus drivers to pick up/drop off passengers with disabilities at the nearest safe location, typically at the corner or at a driveway.¹⁰² SAM allowed riders with disabilities who wished to travel to these flagged stops to be accommodated by Paratransit, even if they were not otherwise

¹⁰¹ *Id.*

¹⁰² *Id.*

Paratransit-eligible. As discussed below, these conditions have largely been ameliorated with the addition of new bus pads.

C. Paratransit

Sioux Area Metro provides a curb-to-curb Paratransit service (door-to-door when necessary), which is available for people who cannot access the fixed-route system because of a disability. To use the Paratransit service, a person needs to be “Paratransit-eligible” by completing an application and participating in an interview. The process may involve verification of the conditions of the disability from a medical professional.¹⁰³

If it is determined that a person cannot access the fixed-route bus system and eligibility is granted, it is required that a ride reservation be made no earlier than ten days prior to the ride, and no later than by 5 p.m. the day before the ride is needed. If a rider goes to the same place at the same time every day using Paratransit service, a subscription ride may be established, which automatically schedules the rides and for which no reservation is required.¹⁰⁴

The established Paratransit service area for SAM primarily follows the required three-fourths of a mile area on each side of the City’s fixed routes per the ADA’s guidelines.¹⁰⁵ The Paratransit service area was narrowed to more closely follow the three-fourths of a mile area in 2015 (though existing riders who received service in the prior, broader area can still get service

¹⁰³ SAM Paratransit Application. Available at <https://www.siouxfalls.org/sam/paratransit/mobility-needs-app>.

¹⁰⁴ *Id.*

¹⁰⁵ See Sioux Falls Area Metro Transit Routes and Paratransit Local Service Area map. Available at: <https://www.siouxfalls.org/sam/paratransit/service-area-map>.

in the expanded area).¹⁰⁶ As fixed-routes are expanded, the City plans that the Paratransit service area would be expanded in conjunction.

There are 25 Paratransit buses. Frequently, all buses are used during peak ridership times. Paratransit service starts each day at 5:15 a.m., with the last pick-ups scheduled for 7:15 p.m. and 9:15 for those adjacent to a fixed route which runs until 9:15 p.m., Monday through Friday. Saturday service begins at 7:30 a.m., with the last pick-ups scheduled at 7 p.m. These hours are comparable to service provided on the fixed route system. Review of reservation requests confirms that capacity appears adequate and denials are rare or non-existent.¹⁰⁷

Paratransit had an on-time performance averaging 92% in 2010 and 96% in August 2011 and 99% in 2019.¹⁰⁸ Paratransit fares are \$2.50 per trip, one and a half-time that as fixed route buses, as permissible under the ADA.¹⁰⁹

V. Potential Challenges to the Current System and Recommendations

Review of many documents, discussions with City staff, riders and the public, and tours of the City by car and on a City bus accompanied by SAM staff and a concerned rider revealed several ongoing issues affecting the public transportation system. These challenges are not necessarily unique to Sioux Falls.

¹⁰⁶ See Paratransit Service page. <https://www.siouxfalls.org/en/sam/paratransit>.

¹⁰⁷ Meeting with Karen Walton (SAM General Manager), Randy Hartman (SAM Assistant General Manager) & Debra Gaikowski (City Planner for Transportation), October 3, 2011.

¹⁰⁸ *SAM On-time performance*, On time performance.xlsx. (Appendix 3). 2019 PTAB annual report <https://www.siouxfalls.org/mayor/boards-commissions/public-transit-advisory-bd/annual-reports>.

¹⁰⁹ *Sioux Falls Transit Development Plan, 2011-2015* at 7. Available at: http://www.siouxfalls.org/Planning/long_range/master_plans/documents/transit_development. See *Transportation Services for People with Disabilities*, Federal Department of Transportation, 49 C.F.R. § 37.131(c).

These issues include: (a) financial pressures, (b) snow removal delays, (c) inaccessible bus stops and sidewalks, (d) maintenance issues, (e) signage, (f) driver training and procedures, (g) governance, and (h) technology.

A. Financial issues

Budget pressures, due to the present economy, changing ridership, and increasing costs affect SAM generally. Reduced funding affects facility repairs, improvements, and expansions. By its nature, Paratransit service is more expensive on a per passenger basis because of the low number of passengers served at any given time. In 2010, Paratransit service accounted for 48% of the City’s total transportation operating costs.¹¹⁰ The cost of Paratransit is expected to rise.

- Recommendation: The City and SAM should continue to investigate appropriate options to decrease reliance on Paratransit. By its nature, Paratransit is more expensive on a per passenger basis than fixed-route bus systems. In earlier discussions with the City, the Authors noted that most of the other issues listed above, from sidewalks generally, to inaccessible bus stops specifically, inadequate snow removal, and problems with signage, may contribute to more passengers using Paratransit as opposed to the fixed route bus system.

Between 2013 and 2015, in response to the authors recommendation, SAM and the City installed accessible bus pads. The City has funded work to improve the

¹¹⁰ 2040 Long Range *Transportation Development Plan, 2011-2015* at 29. Available at: <https://www.siouxfalls.org/-/media/Documents/planning/transportation/long-range/2040-LRTP-Final-Nov2015.ashx> .

Chapter 2 – Transportation

accessibility of the sidewalks by completing installation of curb ramps and ameliorating other sidewalk defects. The City should continue to improve sidewalk accessibility which may decrease reliance on Paratransit for some users.¹¹¹ The Public Transit Advisory Board (PTAB) considered as an alternative to Paratransit the use of taxi vouchers, but concluded this approach is not yet viable given the private taxi market.

Interviews with riders and organizations for people with disabilities suggest that reaching out to riders through marketing and training to demonstrate the accessibility of the fixed route system may increase use of the fixed route system by some Paratransit riders.

Broadly speaking, if the City may better address factors limiting use of its fixed route system, use of the fixed route system may increase and reliance on Paratransit decrease. If short-term costs associated with improvements are addressed, this may yield longer-term financial savings.

In addition, the City and SAM are undertaking a substantial modification to the Paratransit program. In 2014, a Transit Task Force was established to develop a long-term sustainable transit strategy.¹¹² The Task Force goals were primarily to reallocate Paratransit

¹¹¹ The City utilized funding made available for bus pads and many curb ramps. Some intersections still need curb ramps. See details in Chapter 3.

¹¹² See 2014 Transit Task Force Report. Available at:

http://www.siouxfalls.org/~media/Documents/meetings/transit-taskforce/2014-Task_Force_Report_FINAL.pdf.

Chapter 2 – Transportation

spending by decreasing Paratransit costs and using those funds to increase fixed-route service over a five-year period. The 2014 Task Force proposed that SAM:

- Develop a tripper route for ambulatory persons for work trips.¹¹³
- Update and invest additional resources into the Transit Travel Training program to increase fixed-route ridership and decrease paratransit.
- Focus on travel training initiatives including a new buddy system to provide different levels of support for learning how to ride the bus.¹¹⁴
- Increase non-profit organization coordination to better utilize available grants and donations.¹¹⁵
- Reduce reliance on Paratransit use by third-party agencies (primarily Lifescape and DakotAbilities) for their clients' work trips by enabling the agencies to provide transit services on their own or in conjunction with the fixed-route bus system. The City expects this to be a primary driver of decreased Paratransit use and expense and that the City may need to contribute resources to enable expanded transit capacity by the agencies.¹¹⁶
- SAM may also charge higher "agency" rates to these agencies for rehabilitation work trips where the ride is part of the rehab process (as opposed to for the benefit of the individual).

¹¹³ *Id.* at p. 2.

¹¹⁴ *Id.* at p. 3.

¹¹⁵ *Id.* at p. 4-5.

¹¹⁶ *Id.* at p. 4-7.

Chapter 2 – Transportation

- Expand capacity by working with non-profit agencies to provide rides and provide some rides to ambulatory riders via a program named Project Car.¹¹⁷
- Coordinate better with human services agencies (nursing homes, independent living facilities) for appointment scheduling through the City’s 211 HelpLine.¹¹⁸
- Reduce Paratransit coverage area, which is currently available in some parts of the City beyond the required corridor, and align it with the federal minimum three-quarter mile area surrounding fixed-route bus routes. The City expects that rides to these areas could be accommodated by Project CAR, non-profit providers, private providers, or Workers on Wheels.¹¹⁹
- Work with the medical community and developers to inform and advise where transit service is available. (After Paratransit service area is limited to required areas). This report states that this information may then allow organizations and businesses to tap into a private or non-profit transportation option as called for in other work actions of this report.¹²⁰
- Support corporate funded projects, such as accessible taxis, rideshare companies and program-centered transit to allow users to attend evening events.¹²¹

¹¹⁷ *Id.* at p. 8.

¹¹⁸ *Id.*

¹¹⁹ *Id.* at p. 8-9.

¹²⁰ *Id.* at p. 9.

¹²¹ *Id.* at p. 9-10.

Chapter 2 – Transportation

- Increase fixed and Paratransit fares by fifty percent as fares have not kept up with inflation.¹²² Fixed-route base fares would rise to \$1.50 and all Paratransit fares would rise to \$3.00. (Fares were actually raised to \$1.50 and \$2.50 respectively).

The City and SAM completed a similar plan in 2016. The 2016 Transit Development Plan¹²³ proposed strategies to deliver effective transportation in a fiscally responsible manner.¹²⁴ It envisioned significant cost savings by reducing paratransit demand primarily due to the above-described issue of human service agency trips. SAM has now moved approximately 50-60% of paratransit rides to River City Transit for agency trips (Lifescapes, DakotAbilities and schools).¹²⁵ The 2016 plan proposed:

Goal 1: Reduce the cost of paratransit over the next five years, from 48 percent of the total budget to 25 percent the total budget (\$1.8 million reduction in today's dollars).¹²⁶

...

Goal #3: Foster a community-based collaboration for funding an annual operating budget of \$500,000 per year for a coordinated nonprofit transportation effort to support agency work trips, medical trips, and event trips as a high priority of unmet needs of Sioux Falls.

¹²² *Id.* at p. 11-14.

¹²³ *Sioux Falls Transit Development Plan*, Oct. 28, 2016. Available at <https://www.siouxfalls.org/mayor/boards-commissions/public-transit-advisory-bd/transit-dev-plan>.

¹²⁴ *Id.* at p. 4.

¹²⁵ Conversation with Planning Staff, Aug. 20, 2020.

¹²⁶ Paratransit accounted for approximately 42% of SAM's budget in 2019. Conversation with Planning Staff, Aug. 20, 2020.

Chapter 2 – Transportation

Goal #4: Develop a multifaceted transit travel training program that helps instruct at least 1,000 people each year on how to ride the bus.¹²⁷

The plan proposed to achieve this via various strategies and to work with the human service agencies to lobby South Dakota legislature to balance funding to allow the agencies to manage their transit needs while decreasing the cost and usage attributable to Sioux Falls and SAM.¹²⁸ The 2016 plan and conversations with SAM personnel indicate that there is not at present an adequate taxi market to significantly assist Paratransit.

The bulk of the 2014 Transit Task Force Plan's and 2016 Transit Development Plan's effects have fallen on and affect people with disabilities. The City's and SAM's need to reduce Paratransit spending relative to fixed route spending is apparent. While none of the proposed actions appear to violate federal statutes or regulations on their face, the City and SAM will need to work hard to minimize negative impacts. The City and SAM face the potential to lose cooperation in the plan if riders with disabilities, third-party providers, and others feel the City's and SAM's ameliorative plans are inadequate on their face, or not adequately pursued.

- Recommendation: The City and SAM will need to ensure third party providers (i.e., River Cities Public Transit) are capable of accommodating work trips, or the other services they provide will end up diminished. The community will need to maintain its commitment to effectuate the proposed Paratransit use reduction while augmenting its loss in areas of the city. In the alternative, these areas and

¹²⁷ *Id.* at p. 4.

¹²⁸ *Id.* at p. 35-36.

Chapter 2 – Transportation

businesses will become, in essence, further segregated. Riders we spoke with complained about lack of access to developing parts of town.

- For example, financial and other considerations have led Lifescapes to place homes farther from downtown, but where there are fewer transportation options (and some potentially outside the ¾ mile paratransit service area). Riders with disabilities also complain about access to evening events, and the resultant financial and social effects on people with disabilities. Finally, the City may continue to pursue aggressive alternatives, perhaps more attractive fares for fixed route use. The City has investigated accessible cabs in the past, but the City does not appear closer to a result on this problem in the current plan.

On the plus side, riders were complimentary of Paratransit drivers and felt the River Cities Public Transit system is working well for now.¹²⁹

B. Snow

Snow removal is managed by the City in multiple layers. SAM personnel clear the bus parking lots and then fan out to address the Bus Stop and Southwest Transfer Center, followed by individual bus stops. Where there are shelters, SAM is responsible for clearing them and surrounding areas. At stops with benches, the contractor is responsible for the area around the bench. Finally, private landowners are responsible for sidewalks abutting their property as well as the corners.

¹²⁹ Conversation with Steve Watkins (LifeScape) and Nathan Stallinga (DakotAbilities), Aug. 31, 2020.

Chapter 2 – Transportation

Bus drivers are directed to report to SAM where snow needs removal and to pay particular attention to these issues for stops serving people with disabilities.¹³⁰ Snow removal failures are a dominant grievance voiced by the public in complaints reviewed and in the public hearings. Snow impedes and outright prevents people with mobility disabilities from traveling generally and using public transit specifically.

Snow (and to a lesser extent rain) hinders travel by forcing riders to traverse snow piles or large puddles. Even when a rider is capable of traversing the obstacle, riders with visual disabilities, for example, may not know of the existence and extent of obstacles, and thus face potentially dangerous conditions, more so than riders without disabilities.

- Recommendation: Snow removal will continue to be a difficult issue for SAM and the City generally. Sioux Falls has a distributed system of responsibility for snow removal relying on private landowners and contractors for removing snow, but the City remains responsible ultimately for ensuring its bus stops and sidewalks remain accessible under title II and Section 504. As a result, while temporary unavailability due to snow or other conditions may be acceptable, the City and SAM need to make reasonable efforts to ensure sidewalks and bus shelters remain accessible. The standard for reasonableness in this regard is not clear.

The City's current standard of 48 hours after a storm in fact may be reasonable. However, we advise the City to further improve enforcement of and implementation of its efforts to conform to a reasonableness standard. By reports, some sidewalks

¹³⁰ Monthly Driver Training Agenda, January, 2011. Attached as Appendix 4.

remain impassible for people with disabilities for substantially longer periods. By approximation from these reports, some sidewalks are blocked substantially in parts for five days per storm, meaning that sidewalks may remain impassible for up to one month per year. Whether that situation is reasonable is a more doubtful proposition. SAM drivers are instructed to observe and report issues with bus stops. SAM should report these issues timely to other department for their correction and to institute enforcement against delinquent private parties.

C. Inaccessible bus stops and sidewalks

As noted, in 2011 SAM personnel determined that approximately 25% of fixed bus stops were inaccessible. This situation may have increased demand for Paratransit use (for riders trying to get to specific stops). It may have an even more substantial effect on Paratransit use by conditioning riders with disabilities who might otherwise use the fixed route system to unnecessarily rely on Paratransit.

In addition to problems at bus stop landings, there are noted other hindrances to access, such as lack of accessible sidewalks and lack of safe crossing areas. For example, at a bus stop on South Shirley Avenue near South Louise Avenue, the stops were located in the middle of the block at least 100 yards from the traffic controlled intersection. Similarly, at a stop that was under construction on North West Avenue, and others in the area around the Convention Center, the bus stop was located along the main road and riders were forced to cross a service road to reach the sidewalks. On the fixed routes, where bus stops were inaccessible, commenters noted variability as to how and where drivers drop off people with

disabilities. In response to these observations, we recommended between 2011 and 2013 that SAM and the City take a number of tangible steps to increase accessibility at its fixed route bus stops, including:

- Accessibility Reviews. At the recommendation of the authors, SAM officials surveyed all bus stops to classify the degree of accessibility at each bus stop. A regular and thorough review process for City bus stops will help SAM and the City assess access issues at each. The accessibility review determines whether a stop meets minimum current (or former) guidelines with respect to the stop itself, but also categorized the surrounding environs. This included, for example: (1) whether the stop was accessible (and why or why not), (2) if it was not accessible, whether and where there are safe locations nearby for boarding and unloading passengers with different disabilities (mobility, sensory, cognitive, health), (3) maintenance issues present, and, (4) analysis of issues surrounding the stop to determine short-term and longer-term steps needed to increase accessibility and safety. This and other information will allow a prioritization of bus stop improvements to be completed and incorporated into the future City operational budgets, as noted below.
- Address simpler issues sooner. For example, at the above noted bus stops on Shirley and NW Avenue, safety and access for all may be enhanced by designating a pedestrian cross walk with painted lines. In other locations, where, for example, a narrow sidewalk limits extension of bus lifts with room for a wheelchair to enter or

Chapter 2 – Transportation

- exit, SAM may investigate a program of deploying pads only or widening sidewalks (without initially having shelters) as affordable expansion plans in the near term.
- Accessible pads will not only increase access, but also improve efficiency over the current system whereby drivers must locate nearby safe, but perhaps, less than optimal and inconsistently used alternative stops.
 - Supplementary stopping areas: SAM drivers drop riders at safe areas nearby when bus stops are inaccessible. Reports from riders suggest there is variability amongst drivers in this regard. SAM may create a standard process for drivers to select and report the location of safe alternative spots, to be included in the SAM driver monthly meetings, so as to have a clear and consistent system amongst drivers and the riding public.
 - Improve Sioux Falls / SAM Integration: SAM personnel may improve organizational integration with City departments, as discussed above. For needed access improvements, such as improved sidewalks surrounding bus stops, SAM may coordinate access needs regularly with the Engineering Department, which is making notable strides to improve sidewalk access. A more integrated access analysis may result in better decisions about sidewalk and cutout projects and their program and cost-effective prioritization by Engineering.
 - Improve bus stops: As part of a longer-term capital project, SAM and the City may continue to deploy bus pads, and investigate doing so more rapidly, more full bus stops with pads and shelters. Bus pads will improve accessibility while increasing

efficiency by allowing drivers to board and deploy passengers with disabilities at safe, consistent, and predictable locations across seasonal weather patterns. SAM and City personnel have over this past year developed an accelerated plan to deploy bus pads at most, if not all, inaccessible stops. Eighty-eight stops needed pads while thirteen more are located in an area without an accessible sidewalk. SAM and City personnel projected \$40,000 could be allocated under the current budget to build out these pads in 2-3 years.¹³¹

In response to the authors' recommendations and the results of the bus stop survey, City staff presented a plan to the City Council, which approved the required \$46,000 in funding to install bus pads. Since 2013, the City / SAM installed 95 accessible bus pads and stops.

D. Maintenance issues

We observed one example of weather damage to one of the sidewalk cutouts at The Bus Stop during our August, 2011 visit. We also observed and, at public forums, heard reports of, damage to sidewalks and ramps near several other City bus stops. As a result, in 2013, we proposed the following:

- **Recommendations:** As noted, we observed weather damage to one of the sidewalk cutouts at The Bus Stop during our August, 2011, as well as damaged sidewalks near other bus stops throughout the City. Questions about these issues that we posed to City personnel suggest a clearer delineation of responsibility by City departments may aid in timely addressing these issues.

¹³¹ Meeting with SAM and Engineering personnel, Jan. 13, 2013.

Chapter 2 – Transportation

The City ADA Coordinator’s office may aid in clarifying such departmental obligations. In any event, the City and SAM should not rely primarily on rider complaints and driver observations to identify and address such problems. Unlike other “program access” responsibilities, ensuring that accessibility features are maintained at dedicated transit facilities carries a higher obligation under the ADA. To the extent it does not do so, SAM may develop a proactive and cross-department inspection regime of the accessibility of its bus stops to identify problems that confront persons with varying disabilities.

Many of these issues are weather related, and an annual inspection during the spring months seems advisable.

We also suggested, and report on in the chapter on technology access, that the City’s Technology department may develop or maintain reporting systems to allow citizens and City personnel to document access issues via real time geotagged photographs taken on a user’s smartphone and submitted to an online City database. Such systems, which are increasingly available, may assist SAM and the City in locating and correcting maintenance issues in a timely, orderly, and cost-effective manner.

- The City has adopted some of these earlier recommendations, now utilizing a “See Click Fix” system and other maintenance inspections in addressing a 2018 Federal Highway Administration ADA complaint, discussed below in Section 3.

- SAM staff, including drivers, discuss maintenance issues at weekly meetings.¹³²

E. Signage

We observed and received comments from citizens that, at some bus stops, confusing signage makes determining the location of the stop difficult, which may be especially difficult for people with visual and cognitive disabilities. The bus stop accessibility survey discussed earlier shows many bus stop signs face the street (and not the sidewalk), are high and in the wrong location, and present problems that limit accessibility and usefulness for all riders. As a result, in 2013, we proposed the following

- Recommendation: SAM officials report general plans to improve bus stop signage in the near term. Plans may include clear placement of signs relative to stops, ensuring that signs are visible from the sidewalk (as some signs now are only visible from the street side), and that signs comply with visibility requirements in the Federal Regulations and ADAAG.¹³³

In response, the City / SAM installed 387 new bus stop signs.

F. Training and Procedure

Commenters at public forums were overwhelmingly complimentary of the SAM drivers as courteous and helpful. However, one issue concerning the drivers was frequently raised:

¹³² Conversation with Planning Staff, Aug. 20, 2020.

¹³³ Requirements are found in the 2004 ADAAG at section 810. See Appendix 1.

Chapter 2 – Transportation

Paratransit users were not able to communicate with drivers before pickup, leading to concerns about late pickups and waiting in inclement weather, among others.

- Recommendation: Paratransit riders requested to receive communications from drivers when issues arose regarding late pickups, or when drivers were approaching. With the fear of losing eligibility if they are late, along with general concerns, this lack of communication is strongly voiced amongst Paratransit users.

SAM officials are properly concerned about safety issues that may arise if drivers call ahead. However, SAM officials report that drivers are in regular communication with dispatchers. SAM may consider publicizing this availability so riders are encouraged to communicate with the dispatchers. SAM may consider other technology-based solutions. Paratransit buses currently are tracked by location. If this information is communicated to waiting Paratransit riders (if privacy concerns can be addressed), it may improve efficiency, safety, and experience for riders and SAM drivers.

Some commenters indicated that riders find navigating the bus system confusing, especially for new riders, older riders, immigrants and some people with disabilities.

- Recommendation: The City and SAM currently offer training and videos to assist riders in learning how to utilize the bus system.¹³⁴ The City and SAM should evaluate

¹³⁴ See Bus Travel Training Information flyer. Available at <https://www.siouxfalls.org/sam/training-guide>. How to Ride Videos. Available at <https://www.siouxfalls.org/sam/video-tutorials>.

how this information is marketed so more potential and new riders are aware of the training, and modify the training if necessary to improve its effectiveness.

G. Governance

Many of the challenges to be addressed that we identify herein concern multiple different City departments. Issues with, for example, bus stop and sidewalk maintenance, accessibility and integration, and snow removal, involve multiple City departments.

- Recommendation: SAM personnel may improve integration with City departments. SAM and relevant City agencies may better ensure they regularly work together to maintain and improve accessibility by creating inter-department working groups to integrate responses, led by the City ADA Coordinator's office.

H. Technology

The ADA requires the City's and SAM's website to be accessible to users with sensory and other print-related, cognitive and physical (e.g., dexterity) disabilities. We address this issue in the chapter on City technology services, examining technology accessibility City-wide, as well as technologies the City may use to simplify maintenance procedures, as discussed above.

At public forums for this review, individuals with hearing impairments, for instance, noted little, or no way, of knowing when they were approaching their bus stops, particularly in unfamiliar areas.

- Recommendation: SAM should investigate the feasibility of adding electronic signage on its current fixed-route buses to assist riders with auditory and other disabilities, as well as the general public, in knowing route information and stops.

Chapter 2 – Transportation

Chapter 3 – Sidewalks & Public Rights of Way

I. Federal Requirements

Sidewalks, and other aspects of the public rights-of-way,¹³⁵ are required to be accessible under U.S. Department of Justice (DOJ) and U.S. Department of Transportation (DOT)¹³⁶ regulations detailing the requirements of the ADA, Section 504, and other federal laws. According to the DOJ, and as confirmed by two U.S. Courts of Appeals,¹³⁷ the provision of sidewalks constitutes a service, program or activity. The failure to make sidewalks accessible

¹³⁵ “Public rights-of-way” are not defined under the ADA or DOJ ADA regulations. However, proposed regulations issued by the Architectural and Transportation Barriers Compliance Board (Access Board) governing public rights of way define them to mean “public land or property, usually in interconnected corridors, that is acquired for or dedicated to transportation purposes.” See R105.5, *Americans with Disabilities Act (ADA) Accessibility Guidelines for Buildings and Facilities: Public Rights-of-Way*, (Access Board Public Rights-of-Way Guidelines), 76 Fed. Reg. 44664, 44688 (Published July 26, 2011). Available at: <http://www.gpo.gov/fdsys/pkg/FR-2011-07-26/pdf/2011-17721.pdf>. The guidelines reference public streets, sidewalks, and overpasses, and address sidewalks and streets, including crosswalks, curb ramps, street furnishings, pedestrian signals, parking, and components of public rights-of-way such as pedestrian equipment on such places including benches, bus stop shelters, signals, and the like.

¹³⁶ Department of Transportation regulations are discussed in more detail *infra* in the transportation chapter II.

¹³⁷ See *Frame v. City of Arlington*, 657 F.3d 215 (5th Cir., en banc), *cert. denied*, 2/21/2012; *Barden v. City of Sacramento*, 292 F.3d 1073 (9th Cir. 2002), *cert. denied*, 539 U.S. 958 (2003). See also *Hamer v. City of Trinidad*, 924 F.3d 1093 (9th Cir. 2019), *cert. denied*, 140 S.Ct. 644 (2019); *id.* at 1097 (“We hold that a public entity violates Title II of the Americans with Disabilities Act and section 504 of the Rehabilitation Act each day that it fails to remedy a noncompliant service, program, or activity. As a result, the applicable statute of limitations does not operate in its usual capacity as a firm bar to an untimely lawsuit. Instead, it constrains a plaintiff’s right to relief to injuries sustained during the limitations period counting backwards from the day he or she files the lawsuit and injuries sustained while the lawsuit is pending. Because the district court applied a different and incorrect standard, we reverse and remand for further proceedings.”). But see *id.* at 1104 & n.7 (“After all, if sidewalks and curb cuts actually do constitute a service, program, or activity of a public entity—a question that we express no opinion on today—a qualified individual with a disability would still “be excluded” from utilizing any given sidewalk or curb cut each day that it remained noncompliant.” [“7 We assume only for the purposes of this appeal that sidewalks and curb cuts constitute a service, program, or activity.”]).

Chapter 3 - - Sidewalks & Public Rights of Way

constitutes prohibited discrimination. The regulations add detail to the general requirements found in the language of the statutes.

DOJ regulations and other current authority, as detailed below, require new or altered sidewalks to be accessible regardless of cost unless not technically feasible,¹³⁸ and require state and local governments to make existing sidewalks accessible over time by installing curb cuts and other features.¹³⁹ Federal guidance has clarified that any resurfacing of a stretch of road constitutes alteration, not only where the roadway is milled prior to resurfacing.¹⁴⁰

The important relation between transit and sidewalk access was emphasized in the U.S. Court of Appeals for the Fifth Circuit's 2011 full court (i.e., *en banc*) decision in *Frame v. City of Arlington*. The Court observed:

... in clarifying the requirements of Title II in the unique context of "designated public transportation services" (e.g., regular rail and bus services), Congress expressly provided that § 12132 requires new and altered "facilities" to be accessible. Although Congress did not define "facilities," the relevant

¹³⁸ 28 C.F.R. §§ 35.151(i). Effective March 15, 2011, Section 35.151(e) was redesignated as Section 35.151(i). See 75 Fed. Reg. 56, 164, 56, 217 (Sept. 15, 2010).

¹³⁹ 28 C.F.R. §§ 35.150(d)(2).

¹⁴⁰ The guidance notes: "Resurfacing is an alteration that triggers the requirement to add curb ramps if it involves work on a street or roadway spanning from one intersection to another, and includes overlays of additional material to the road surface, with or without milling. Examples include, but are not limited to the following treatments or their equivalents: addition of a new layer of asphalt, reconstruction, concrete pavement rehabilitation and reconstruction, open-graded surface course, micro-surfacing and thin lift overlays, cape seals, and in-place asphalt recycling." See *Department of Justice/Department of Transportation Joint Technical Assistance on the Title II of the Americans with Disabilities Act Requirements to Provide Curb Ramps when Streets, Roads, or Highways are Altered through Resurfacing*. Available at: http://www.fhwa.dot.gov/civilrights/programs/doj_fhwa_ta.cfm. A glossary of these terms as used by the FHWA is available at: https://www.fhwa.dot.gov/civilrights/programs/doj_fhwa_ta_glossary.cfm.

Chapter 3 - - Sidewalks & Public Rights of Way

Department of Transportation (DOT) regulations define the term to include, inter alia, “roads, walks, passageways, [and] parking lots.”¹⁴¹

This interrelation was emphasized in the ADA House report, which noted "local and state governments are required to provide curb cuts on public streets. “The employment, transportation, and public accommodation sections of this Act would be meaningless if people who use wheelchairs were not afforded the opportunity to travel on and between streets.”¹⁴²

While generally requiring “program access,” the ADA and its implementing regulations single out installation of curbs cuts to existing sidewalks to be implemented as part of the required original ADA transition plans.¹⁴³ Thus, while we treat public transportation in this ADA Transition Report in a separate chapter, per the City’s instructions to us, the issues surrounding the City’s bus / Paratransit system and its sidewalks, and other paths of access, are inextricably linked.

The Federal Highway Administration (FHWA), a unit of the DOT, “is responsible for implementation of pedestrian access requirements from the ADA and Section 504 ... through stewardship and oversight over all Federal, State, and local governmental agencies ("public agencies") that build and maintain highways and roadways, whether or not they use Federal

¹⁴¹ Following the denial of certiorari to the Supreme Court, the City of Arlington settled with plaintiffs and agreed to remedy certain sidewalk conditions, and to pay plaintiffs’ attorney fees of \$310,322. Settlement Agreement, *Frame v. City of Arlington*, Civ. 4:05-CV-470 (N.D. Tex. Oct. 2012).

¹⁴² H.R. REP. No. 101-485(1), pt. 2, at 84 (1990), reprinted in 1990 U.S.C.C.A.N. 303, 367.

¹⁴³ See interpretation of 28 C. F. R. 35.151(d)(2) in U.S. DOJ 1991 Section By Section Analysis, 28 C. F. R. 35, p. 202-203 (transition plan must include schedule for curb cuts at existing crosswalks).

Chapter 3 - - Sidewalks & Public Rights of Way

funds on a particular project.”¹⁴⁴ According to the FHWA, the ADAAG is the required standard for minimal compliance, while the Access Board Public Rights-of-Way guidelines are recommended by the FHWA as best practices.¹⁴⁵

Existing sidewalks and curbs are treated differently under the “program accessibility” provisions of the DOJ regulations, discussed in Chapter I, than other types of existing facilities. For most existing facilities that are inaccessible, public entities are not required to make each accessible, but the public entity must “operate each service, program, or activity so that the service, program, or activity, when viewed in its entirety, is readily accessible to and usable by individuals with disabilities.”¹⁴⁶

Instead, the program accessibility requirement regarding curb cuts provides that if “a public entity has responsibility or authority over streets, roads, or walkways, its transition plan shall include a schedule for providing curb ramps or other sloped areas where pedestrian walks cross curbs, giving priority to walkways serving entities covered by the Act, including State and local government offices and facilities, transportation, places of public accommodation, and employers, followed by walkways serving other areas.”¹⁴⁷

¹⁴⁴ See Frederick D. Isler, Associate Administrator for Civil Rights, *Memorandum, Public Rights-of-Way Access Advisory*, U.S. Department of Transportation, Federal Highway Administration, January 23, 2006 (“Isler Memorandum”). Available at: https://www.fhwa.dot.gov/environment/bicycle_pedestrian/resources/prwaa.cfm.

¹⁴⁵ *Id.*

¹⁴⁶ 28 C.F.R. § 35.150.

¹⁴⁷ 28 C.F.R. § 35.150(d)(2).

Chapter 3 - - Sidewalks & Public Rights of Way

The title II regulation required public entities to achieve program accessibility by January 26, 1992. Where structural changes to existing facilities are required to provide program accessibility, 28 C.F.R. section 35.150(c) provides that such structural changes must be made as expeditiously as possible, but in no event later than January 26, 1995, unless the public entity can demonstrate that meeting this deadline would result in a fundamental alteration of its program or would impose undue financial and administrative burdens.

The DOJ proposed to extend the time period for providing curb cuts at existing pedestrian walkways, in a rule published on November 27, 1995.¹⁴⁸ This proposed rule was never finalized, and was formally withdrawn in 2004.¹⁴⁹ As a result, generally, barring undue burden or fundamental alteration defenses, curbs should theoretically have been made accessible by January 26, 1995.¹⁵⁰

While the regulations address curb cuts, DOJ treatment, as well as several court cases, have confirmed that sidewalks and other aspects of such a system are also covered by the statute. “Section 35.150’s requirement of curb ramps in all pedestrian walkways reveals a general concern for the accessibility of public sidewalks, as well as a recognition that sidewalks

¹⁴⁸ See 60 Fed. Reg. 58462.

¹⁴⁹ See 2004 Advanced Notice of Public Rule Making, *Nondiscrimination on the Basis of Disability in State and Local Government Services; Nondiscrimination on the Basis of Disability by Public Accommodations and in Commercial Facilities*, U.S. Department of Justice, 69 F.R. 58768, 58777 (Sept. 30, 2004) (“2004 DOJ ADA ANPRM”).

¹⁵⁰ 28 C.F.R. § 35.150(c).

fall within the ADA’s coverage, and would be meaningless if the sidewalks between the curb ramps were inaccessible.”¹⁵¹

Following adverse court rulings in one landmark case, the city of Sacramento settled with plaintiffs, committing to allocate 20% of its transportation fund to make the city’s pedestrian rights of way accessible to individuals with vision and/or mobility disabilities.¹⁵²

The Federal Highway Administration has issued guidance that specifies the requirements for state transition reports covering public rights of way. The attributes that are required to be included in a State’s ADA transition plan consist of the following:

- 1)** Identification of the official responsible for implementation of the transition plan (See 28 CFR 35.150(d)(3)(iv));
- 2)** An inventory of barriers (i.e., identification of physical obstacles) (See 28 CFR 35.150(d)(3)(i) & 28 CFR 35.150(a));
- 3)** A prioritized schedule of when barriers will be eliminated and deficiencies corrected (See 28 CFR 35.150(d)(2) & 28 CFR 25.150(d)(3)(iii)); and,
- 4)** A description of the methods that will be used to make facilities accessible (See 28 CFR 35.150(d)(3)(ii)).¹⁵³

This is also the appropriate standard for municipal transition plans.¹⁵⁴

¹⁵¹ *Barden v. City of Sacramento*, 292 F.3d at 1077.

¹⁵² See Settlement Agreement, *Barden v. City of Sacramento*, E.D. Ca. (99-497), adopted by court Jan 22, 2004. Available at https://dralegal.org/wp-content/uploads/2012/09/settlement_0.pdf.

¹⁵³ Irene Rico, U.S. DOT, FHWA. ADA transition plan process [memorandum]. Nov. 12, 2015 (“Rico memorandum”) (Statutory formatting in original). Available at: https://www.fhwa.dot.gov/civilrights/memos/ada_transition_plan_111215.cfm.

¹⁵⁴ The Rico memorandum is addressed to state transition plans as funding from the FHWA travels to the state, but the requirements are instructive to municipalities.

Chapter 3 - - Sidewalks & Public Rights of Way

Federal enforcement under the Project Civic Access and other DOJ settlements have not only required that cities install curb cuts at new construction and substantial road work, but have also addressed existing sidewalks. They have required cities to go back and ameliorate sidewalks that have been newly constructed or altered since the ADA but where the cities failed to build in compliance.¹⁵⁵ They have required cities to survey older sidewalks and ameliorate defects (by enforcing local ordinances against landowners or doing the work themselves) in as short as three years.¹⁵⁶

In 2010, the DOJ instituted a final rule to amend its implementing regulations of title II of the ADA.¹⁵⁷ This included adoption of additions to and revisions of the ADA Accessibility Guidelines for Buildings and Facilities (ADAAG). The specifications for curb cuts have been changed in minor ways.¹⁵⁸ The rules include a general “safe harbor” provision under which elements in covered facilities built or altered in compliance with the 1991 ADAAG standards or the Uniform Federal Accessibility Standards (UFAS) are not required to be brought into compliance with the 2010 DOJ Standards until such facility elements are subject to a planned

¹⁵⁵ See, e.g., U.S. DOJ settlement with Kansas City, MO (Dated July 25, 2012). Available at: https://www.ada.gov/Kansas_city_pca/kansas_city_pca_sa.htm.

¹⁵⁶ See Settlement Agreement, *United States v. The City of Hudson*, New York, Oct. 23, 2019. Available at https://www.ada.gov/city_hudson_ny_sa.html. The three-year period to address existing sidewalk was focused on areas where the city provides programs, services and activities directly (e.g., city hall, parks, libraries, police stations, etc.), with other areas to be addressed based on complaints and other procedures.

¹⁵⁷ *Nondiscrimination on the Basis of Disability in State and Local Government Services*, U. S. Department of Justice, RIN 1190-AA46, 75 Fed. Reg. 56164 (Sept. 15, 2010) (“2010 DOJ ADA Regulations”). Available at: <https://www.federalregister.gov/documents/2010/09/15/2010-21821/nondiscrimination-on-the-basis-of-disability-in-state-and-local-government-services>. This rule similarly does not directly apply to SAM, at least with regard to the transportation services, programs, and activities covered by ADA title II, part b.

¹⁵⁸ *Id.* at Rule 405-406.

**Chapter 3 - -
Sidewalks &
Public Rights of
Way**

alteration. This applies to curb cuts. However, other aspects of the public rights-of-way would not be covered where there was no prior standard, such as for pedestrian signals.

The Access Board has been in the process of formulating formal policies for all aspects of the public rights-of-way since the early 1990s. After initial proposals met with various criticism, the Access Board has sponsored research and issued refined proposed guidelines several times.

On July 26, 2011, the Access Board issued its latest proposed guidelines incorporating the research and responses.¹⁵⁹ While not yet formally adopted as standards, these guidelines form the recommended best practices to address accessibility for all aspects of the pedestrian rights-of-way.¹⁶⁰ The Access Board Public Rights-of-Way Guidelines are substantially similar to the 2010 DOJ ADA Regulations with areas that will have more than minimal impacts on transportation departments:¹⁶¹

- Detectable warning surfaces on curb ramps and blended transitions at pedestrian street crossings (see R208.1 and R305);
- Accessible pedestrian signals and pedestrian pushbuttons (see R209);
- Pedestrian activated signals at roundabout intersections with multi-lane pedestrian street crossings (see R206 and R306.3.2); and,
- Accessible on street parking providing a certain number of designated accessible parking spaces and technical requirements to ensure safe access for drivers and

¹⁵⁹ *Access Board Public Rights-of-Way Guidelines*. 76 F.R. 44664-44698.

¹⁶⁰ See *Isler Memorandum, supra*, Note 144. The City has adopted a policy of compliance with the Access Board Public Rights of Way Guidelines.

¹⁶¹ *Id.*, 76 F.R. at 44670.

Chapter 3 - - Sidewalks & Public Rights of Way

passengers to be able to enter and exit the vehicle and to provide access to the sidewalk (see R214 and R309).

Regulations governing accessible on-street public parking are pending as noted under the *Access Board Public Rights-of-Way Guidelines*.¹⁶² While regulations regarding accessible on-street parking are still pending, and thus not mandated, providing accessible parking spaces in accord with the *Access Board Public Rights-of-Way Guidelines* represent a best practice.¹⁶³

One Ninth Circuit U.S. Court of Appeals opinion affirms that even in the absence of mandated standards, provision of accessible, on-street parking is mandated by the program access and new construction accessibility requirements of the ADA.¹⁶⁴ Other cities, such as New York City and Baltimore, have adopted permitting regulations or design guidelines to augment accessible on-street parking.¹⁶⁵

II. Sioux Falls Sidewalks

Sidewalks constitute a significant part of the transportation network of Sioux Falls. In 2016, the City of Sioux Falls completed and approved the Shape Sioux Falls 2040 Plan,¹⁶⁶ which is a comprehensive development plan used to guide city growth and development.

¹⁶² *Id.*

¹⁶³ See *Islar Memorandum, supra*, Note 144160.

¹⁶⁴ *Fortyune v. City of Lomita*, 766 F.3d 1098 (9th Cir. 2014), *cert denied* 135 S.Ct. 2888 (2015).

¹⁶⁵ See New York City, Department of Transportation guidelines on New York City Parking Permits for People with Disabilities. Available at: <https://www1.nyc.gov/html/dot/html/motorist/pppdinfo.shtml#nycpermit>.

¹⁶⁶ *Shape Sioux Falls 2040 Plan*. Available at <https://www.siouxfalls.org/planning-dev/planning/comp-plan>.

Chapter 3 - - Sidewalks & Public Rights of Way

This review reinforces the need for sidewalk and pedestrian connectivity. The City of Sioux Falls has adopted a Complete Streets policy,¹⁶⁷ Resolution 53-15, for planning, designing, and constructing all new City transportation improvement projects in an effort to accommodate pedestrians, bicyclists, transit riders, motorists, and persons of all abilities, while promoting safe operation for all users.

Over the years, Sioux Falls has made substantial progress towards making its sidewalks accessible to people with mobility and other disabilities. The Engineering Department has worked over the past decades to include curb ramps when streets are rehabilitated. This has led to the majority of curbs at intersections having curb ramps.

While there has been substantial progress, at the time we began our work with the City in 2011, issues remained in three primary areas: (1) planning to complete curb ramp deployment at remaining corners where they are lacking; (2) inaccessible sidewalks and bus stops; and (3) general maintenance of sidewalks and curb ramps and snow removal. The City has made progress on these issues. However, in part in response to a citizen complaint, the City further adopted in 2018 an expanded transition plan addressing public rights of way.¹⁶⁸ These sidewalk accessibility issues are discussed in below.

A. Sidewalks and Curb Ramps

¹⁶⁷ *Complete Streets*, Available at <https://www.siouxfalls.org/planning-dev/planning/complete-streets>.

¹⁶⁸ *Transition Plan: Accessibility of Pedestrian Facilities in the Public Right-of-Way*, March 30, 2018 (“2018 PROW Transition Plan”). Available at <https://www.siouxfalls.org/public-works/engineering/sidewalks/transition-plan>.

Chapter 3 - - Sidewalks & Public Rights of Way

The City primarily installs curb ramps in conjunction with street rehabilitation projects. The Engineering Department coordinates street rehabilitation over periods of years where some streets with high traffic are repaved more frequently, while some streets have not been repaved since before the passage of the ADA.¹⁶⁹ The City had deployed between 63 and 345 curb ramps per year over the past decade, primarily during street reconstruction (“overlays”).¹⁷⁰ However, our discussions with Engineering Department personnel revealed that the City needed to establish a more developed plan to complete curb ramp deployment over a reasonable time period.

At the suggestion of the authors, Engineering Department personnel made a complete assessment of remaining curb ramp needs in 2012-2013, mapped them next to street overlays planned, and estimated that of the remaining missing curb ramps: 429 would be installed over the next two to five years in association with street repair projects, but that between 136-182 ramps were needed on streets that were not expected to undergo street repair between 2013-2018.¹⁷¹

To expedite deployment, the Engineering Department proposed to reorder some street repairs to capture more curbs, and to address other curbs separately from the overlay program. They estimated that utilizing and reallocating existing funds, all curbs would have ramps in

¹⁶⁹ Interviews with Engineering Department personnel, Aug. 24, 2011; Sept. 27, 2011; Mar. 14, 2012 & Aug. 31, 2012.

¹⁷⁰ See Appendix 5, *Ramps Installed – Overlays and Reconstructions*.

¹⁷¹ Interview with Engineering Department personnel, Aug. 31, 2012.

Chapter 3 - - Sidewalks & Public Rights of Way

approximately five years (approximately \$640,000 for the 136 renovations from neighborhood restoration funds and \$2 million as part of the already-planned overlay projects).¹⁷² In 2013, we recommended:

- Recommendation: According to DOJ regulations, existing curbs should have been ameliorated within three years of the ADA. While the DOJ has not been aggressively enforcing this standard, we conclude that it is the basic requirement.

Moreover, as noted above in the transportation chapter, approximately one quarter of the City's bus stops were inaccessible and this is in part related to inaccessible sidewalks. These interrelated problems suggest that coordination between City departments to more quickly improve sidewalk accessibility would improve transportation accessibility overall and may be fiscally prudent (particularly if increased sidewalk accessibility can decrease reliance on inefficient Paratransit usage).

In response, City Engineering personnel developed plans to expedite curb ramp installation and City staff presented the plans and funding requests to the City Council, which approved required \$375,000 funding on May 14, 2013.¹⁷³ The City installed approximately 280 ADA compliant curb ramps in 2013 (79 curbs were addressed using this additional funding).¹⁷⁴

¹⁷² *Id.*

¹⁷³ City Council Meeting, May 14, 2013. Available at: <http://docs.siouxfalls.org/sirepub/mtgviewer.aspx?meetid=1925&doctype=AGENDA>.

¹⁷⁴ Communication with Colleen Moran, former ADA Coordinator.

**Chapter 3 - -
Sidewalks &
Public Rights of
Way**

As of the end of 2014, 262 curbs were to be addressed in future overlay/reconstruction projects, but 103 curbs will remained outside of planned future projects. There was \$150,000 budgeted annually in the Capital Improvement Program for ADA Ramps.¹⁷⁵

As noted, in 2018, partially in response to a citizen complaint and findings of ADA violations by the U.S. Department of Transportation, Federal Highway Administration (FHWA), the City completed an updated public rights of way transition plan.¹⁷⁶ Generally, this further increased the City’s commitment to addressing public rights of way defects. The report recognized the increased ramp construction with the average over the preceding years at 298 new or upgraded ramps per year. The City expected to address the remaining 235 vertical barriers by 2020.¹⁷⁷ As of the fall of 2020, there were 131 vertical barriers remaining and three barrier removal projects that need to be accomplished at an estimated cost of \$825,000.

In 2017, the City completed a thorough evaluation including “sidewalks, curbs, curb ramps, pedestrian signals in the public right-of-way.”¹⁷⁸ “The City implemented best practices standards in its evaluation by following the Chapter 16 Accessible Sidewalk Requirements of the Engineering Design Standards, which incorporate the PROWAG guidelines. The evaluation also included a condition assessment of the pedestrian facilities in the public right-of-way.”¹⁷⁹ This

¹⁷⁶ 2018 PROW Transition Plan.

¹⁷⁶ 2018 PROW Transition Plan.

¹⁷⁷ *Id.* at p. 6.

¹⁷⁸ 2018 PROW Transition Plan at p. 8.

¹⁷⁹ *Id.*

**Chapter 3 - -
Sidewalks &
Public Rights of
Way**

covered a length of over 1,021 miles of sidewalk, 13,557 curb ramps, and 270 traffic signals with 1,130 pedestrian pushbuttons. It was completed in November 2017, and will be updated every 10 years.¹⁸⁰

Discussions with the Engineering Department revealed a need for better coordination with other City departments in other areas. In some instances, the authors observed areas where developers did not build sidewalks, where, according to Engineering, sidewalks should have been included as part of the development.¹⁸¹ This appeared to result where Building Services and Engineering inspected new developments at different times and have different focal points.

The City committed to unify its inspection regime in the 2018 PROW Transition Plan to address all types of new sidewalk and curb ramps (“new development, site redevelopment, homeowner initiated driveway and sidewalk installation permits, private utility construction and the City’s Capital Improvement Program (CIP) Projects”).¹⁸² “As of 2017, all sidewalks installed as a part of these processes will be inspected for ADA compliance, and inspections are documented and retained.”¹⁸³

¹⁸⁰ *Id.*

¹⁸¹ Interview with Engineering Department personnel, 2015.

¹⁸² 2018 PROW Transition Plan at p. 9.

¹⁸³ *Id.* Confirmed in conversation with Wes Philips, Principal Engineer, and Erick Bogue, Assistant City Attorney (Public Works Department), Aug. 20, 2020.

**Chapter 3 - -
Sidewalks &
Public Rights of
Way**

The City has established a prioritization strategy for making accessibility improvements in the public right-of way.¹⁸⁴ The City is working to actively resolve an ADA complaint involving over 11 miles of sidewalks, curb ramps and pedestrian signals. The Mayor’s Recommended Capital Program recommends allocation of \$821,000 for ADA street and sidewalk improvements in 2021 increasing to \$2,200,000 in 2025 for a total of \$6,775,000 over the coming five years.¹⁸⁵

2018 PROW Transition Plan Table 2, Priorities for Public Right-of-Way Pedestrian Facility Accessibility Upgrades¹⁸⁶ (Updated)

Priority	Existing Situation/Accessibility Issue	2017 Number of Non-Compliant Locations ¹⁸⁷	Target Date for Completion ¹⁸⁸	2020 Number of Non-Compliant Locations
1	Non-operational push buttons	84	2 years	2
2	Vertical curb barriers (with no curb ramps) at locations with existing sidewalk crossings.	235	3 years	86
3	Curb ramps in poor condition <60 condition rating	277	5 years	18

¹⁸⁴ 2018 PROW Transition Plan at p. 11.

¹⁸⁵ *Mayor’s Recommended City of Sioux Falls 2021-2025 Capital Program* at p. 9. Available at <https://www.siouxfalls.org/finance/capital-programs/2021-2025/CIP-2021-2025>.

¹⁸⁶ 2018 PROW Transition Plan Progress Report – 2018. Available at <https://www.siouxfalls.org/public-works/engineering/sidewalks/transition-plan-progress-rpt>.

¹⁸⁷ As identified in the 2018 PROW Transition Plan self-evaluation inventory, count may overlap in other categories. Consideration also given to adjacent non-compliant facilities. Non-compliant facilities could include curb ramps, sidewalks, and pedestrian buttons. Priorities 1-7 are tabulated in detail in 2018 PROW Transition Plan, Appendix 9. Available at <https://www.siouxfalls.org/public-works/engineering/sidewalks/transition-plan>.

¹⁸⁸ The target date for completion begins at the point of implementation of the transition plan, March 30, 2018. The date in this column represents an estimate of when the prioritized accessibility issues will be fixed, per the 2018 PROW Transition Plan

**Chapter 3 - -
Sidewalks &
Public Rights of
Way**

4	Push buttons with height less than 15” and more than 48”	122	5 years	104
5	Push buttons with reach distance over 25”	77	5 years	67
6	Clear ground space at pedestrian push buttons with size less than 30”x48” or where none was identified	88	7 years	68
7	Pedestrian pushbuttons with low compliance rating <60	96	10 years	64
8	Vertical faults of ½” or greater on sidewalks and curb ramps ¹⁸⁹	16,013	15 years	14,136
9	Obstructions present on curb ramps and sidewalks (remove or mitigate)	687	15 years	590
10	Curb ramps with low compliance rating <60	1,682	20 years	1452
11	Excessively non-compliant driveways and sidewalk segments with excessive cross slope	1,063	20 years	998

“Within each priority, improvements will be completed in the following order:

1. State, county and local government offices and facilities (City Hall, public schools, public library, etc.)

2. Public transportation facilities (bus stops, train stations, etc.)

¹⁸⁹ The City is prioritizing repairs of vertical faults of one-half inch or greater through the Sidewalk Inspection and Repair Program. Focusing on these defects allows the City to more expeditiously repair the most severe vertical separations. PROWAG requires vertical separations of one-quarter inch to one-half inch to be beveled; these areas will be prioritized for repair as the number of more severe vertical faults are substantially reduced.

**Chapter 3 - -
Sidewalks &
Public Rights of
Way**

3. Places of public accommodation (central business district, public recreation areas, etc.)
4. Residential areas.

Complaints or other urgent accessibility needs may be accelerated based on importance, need and justification.”¹⁹⁰

The City publishes a summary of pedestrian facility upgrades annually to its website.¹⁹¹

The City committed in the 2018 PROW Transition Plan to conduct annual reviews to ensure the 2018 PROW’s goals are being met.¹⁹² Updates in 2018, 2019 and 2020 shows work completed in 2018, 2019 and 2020 and plans for the following years.¹⁹³

B. Sidewalk Maintenance & Snow Removal

As noted above in the Transportation chapter, Sioux Falls has a distributed system of responsibility for sidewalk maintenance and snow removal, relying on private landowners and contractors. But the City remains responsible ultimately for ensuring its bus stops and sidewalks remain accessible under title II and Section 504. This was a major finding in our 2015 draft report and it was highlighted in the findings from the FHWA.

¹⁹⁰ 2018 PROW Transition Plan at p. 11. Available at <https://www.siouxfalls.org/public-works/engineering/sidewalks/transition-plan>.

¹⁹¹ *Id.* at p. 12.

¹⁹² *Id.* at p. 11.

¹⁹³ *Annual Transition Plan Progress Report – 2018*. Available at <https://siouxfalls.org/public-works/engineering/sidewalks/transition-plan-progress-rpt>. *Summary of Annual Progress (2019): ADA Transition Plan for Public Right-of-Way Pedestrian Facilities*. Available at <https://www.siouxfalls.org/public-works/engineering/sidewalks/transition-plan-prog-rpt-19>. *Annual Transition Plan Progress Report (2020)*. Available at <https://www.siouxfalls.org/public-works/engineering/sidewalks/Transition-Plan-Progress-Rpt-2020>.

Chapter 3 - - Sidewalks & Public Rights of Way

As a result, while temporary unavailability due to snow or other conditions may be acceptable, the City and SAM need to make reasonable efforts to ensure sidewalks and bus shelters remain accessible. The standard for reasonableness in this regard is not completely clear. The City's current standard of 48 hours after a storm may be reasonable. By reports, some sidewalks remain impassible due to snow for people with disabilities for substantially longer periods. By approximation from these reports, some sidewalks are blocked substantially in parts for five days per storm meaning that sidewalks may remain impassible for up to one month per year. Whether that situation is reasonable is a more doubtful proposition.

The City investigated changes to its snow removal policies and enforcement in 2011-2012. With little snow during the winter of 2011-12, there was not sufficient experience for us to determine whether these changes will improve snow removal from sidewalks by private parties during a more challenging winter. The City should continue to closely monitor the effectiveness of changes to snow removal policies. The City has posted some notices on its website to notify the public of their obligations.¹⁹⁴ Citizens can report snow removal needs on this site.

Maintenance of sidewalks is the responsibility of the private property owner or person in possession, and failure to properly maintain sidewalks is enforced through the Community Development Department. If a private owner or person in possession fails to maintain his

¹⁹⁴ See <https://siouxfalls.org/code-enforcement/sidewalk-snow>.

**Chapter 3 - -
Sidewalks &
Public Rights of
Way**

sidewalks, the City may intervene and repair or plow the sidewalks at the landholder's expense.¹⁹⁵

However, discussions with City personnel suggest that rectifying physical problems on sidewalks can take months.¹⁹⁶ Some of this time results from due process issues and the procedure through the City Council.¹⁹⁷ City personnel report this process has been working more effectively of late.¹⁹⁸ However, the City's Sidewalk Policy documents that the repair process can take up to a year between identification of a defect, notice to the landowner, and development and bidding of a repair plan (if the landowner does not address it his/her self).¹⁹⁹

The City's sidewalk policy outlines typical timelines and details of the Sidewalk Inspection and Repair Program. The City's goal is to inspect sidewalks within the public right-of-way on a 10-year rotation. Sidewalks in the central business district may be inspected more frequently if needed. To achieve this 10-year rotation, staff must inspect 10 percent of the sidewalks annually. In conversations with the staff, they indicate that they need at least one more person to be able to achieve this and comply with the 2018 PROW Transition Plan agreed to with the federal government.²⁰⁰

¹⁹⁵ *Id.* Revised Ordinances of Sioux Falls, SD, Chapter 96 (cSnow and Ice removal).

¹⁹⁶ Interview with Engineering Department personnel, Aug. 31, 2012.

¹⁹⁷ *Id.*

¹⁹⁸ Conversation with Wes Philips, Principal Engineer, and Erick Bogue, Assistant City Attorney (Public Works Department), Aug. 20, 2020.

¹⁹⁹ 2018 PROW Transition Plan, Sidewalk Policy, Appendix 10 at p. 349. Available at <https://www.siouxfalls.org/public-works/engineering/sidewalks/transition-plan>.

²⁰⁰ Conversation with Wes Philips, Principal Engineer, and Erick Bogue, Assistant City Attorney (Public Works Department), Aug. 20, 2020

1) Recommendation

The City should ensure it fixes public rights of way defects identified in the 2018 PROW Transition Plan and look for ways to expedite the timeline. The City established its broad outline of time to repair defects in a long, considered manner in its 2018 PROW Transition Plan.

While we did not establish whether the City may meet its obligations to inspect and maintain sidewalks with current staffing, comments we heard leave this in doubt. We therefore recommend the City evaluate whether current staffing levels are adequate to inspect the sidewalks, process notices of deficiencies to landowners, and ensure repairs are made.

If not, the City risks being unable to meet its general obligations under the ADA and further action by the FHWA and DOJ. Proactive surveillance and maintenance is a best practice and important tool in maintaining accessibility. We advise the City to further improve enforcement of and implementation of its efforts to conform its maintenance responsibilities to a reasonableness standard and compliance with its settlement efforts.

One additional area in which we believe ameliorating sidewalk defects may be expedited is by accelerating resolution of already detected sidewalk defects. The 2017 survey identified 16,013 defects that would be addressed over 15 years, for example. To the extent these are the responsibility of private landowners, the City could increase its notice rate to those responsible. These defects were not documented in the detailed manner used in the annual inspections, so it did not notice landowners at the time.

**Chapter 3 - -
Sidewalks &
Public Rights of
Way**

Interviews with City personnel indicate that with additional staff in Public Works, work on these issues may be accelerated, and perhaps the 2017 survey could serve as a framework for identifying these areas with adequate formality for notice.²⁰¹ Finally, while we recognize the difficulties created by the 2020 Covid-19 pandemic, the City should update surveys regularly.

C. On-Street Parking

The City currently has a few accessible on-street parking spaces, for example in front of City Hall, that conform to *Access Board Public Rights-of-Way Guidelines*.²⁰² The City has been installing accessible spots in some downtown areas when it reconfigures parking and other street layouts since about 2008.²⁰³ For example, some blocks have been converted to diagonal parking with van-accessible spots near the corners or ramps in the middle of the block in conformance with the *Access Board Public Rights-of-Way Guidelines*.²⁰⁴

People with state disability parking permits can park at meters without having to feed the meter (which is appropriate especially where access to mid-block meters would involve going to a ramp at a corner and then going back up the block to get back to the meter). Residents may petition for spaces to be designated for disabled parking in particular locations, but these are only designations, not accessible on-street parking in the terms of *Access Board Public Rights-of-Way Guidelines* best practices.

²⁰¹ *Id.*

²⁰² *Access Board Public Rights-of-Way Guidelines*. 76 F.R. 44664-44698

²⁰³ Conversation with Heath Hoftiezer, Principal Engineer, Aug. 25, 2020.

²⁰⁴ Placement of spots is determined on a site-specific basis. E.g. on 4th St. it's near the middle, on the other side it's on the ends. The City may add a new ramp or place the accessible parking so as to utilize an existing ramp.

**Chapter 3 - -
Sidewalks &
Public Rights of
Way**

I. Federal Requirements

“Regular physical activity throughout life is important for maintaining a healthy body, enhancing psychological well-being, and preventing premature death.”²⁰⁵ Studies indicate that people with disabilities are less physically active than people without disabilities—although see CDC data for Sioux Falls earlier finding adults with Disabilities nationally are more likely to be inactive but less so in South Dakota. This may be the result in part to disparities in access to exercise and recreation.²⁰⁶

Regular physical activity is associated with lower death rates for adults of any age, even when only moderate levels of physical activity are performed. Regular physical activity improves health quality in a number of areas including heart health, diabetes, weight, and is associated with a decreased risk of colon cancer, healthy weight control, body strength, coordination, and symptoms and incidence of depression.²⁰⁷

In addition, children and adolescents need weight-bearing exercise for normal skeletal development, and young adults need such exercise to achieve and maintain peak bone mass.²⁰⁸ Older adults can improve and maintain strength and agility with regular physical activity. This may reduce the risk of falling, helping older adults maintain an independent living status.²⁰⁹

²⁰⁵ *Healthy People 2010*, U.S. Department of Health and Human Services (Nov. 2000). Available at: <http://www.healthypeople.gov/2010/Document/tableofcontents.htm>.

²⁰⁶ *Id.*

²⁰⁷ *Id.*

²⁰⁸ *Id.*

²⁰⁹ *Id.*

Chapter 4 - - Parks and Recreation

Regular physical activity also increases the ability of people with certain chronic, disabling conditions to perform activities of daily living.²¹⁰ In short, access to exercise and recreation is no less, and perhaps more, important to the health of people with disabilities.

The 1991 ADAAG Standards did not include requirements for the design and construction of play areas. To meet program accessibility requirements where structural changes are necessary, public entities have been required to apply the general new construction and alteration standards to the greatest extent possible, including with respect to accessible parking, routes to the playground, playground equipment, and playground amenities (e.g., picnic tables and restrooms).

In 2000, the Access Board published guidelines to address particular play components, accessible routes connecting the components, accessible ground surfaces, and maintenance of those surfaces. The 2010 Standards adopt the 2004 ADAAG (which includes the 2000 play area guidelines).

The play area guidelines formally require new or renovated play area to have safe yet accessible surfacing materials.²¹¹ These surfacing materials lie under and around playground equipment. At the same time, surface materials must adequately protect a person from a fall from a certain height. Some products, such as loose fill like wood chips may satisfy both if properly maintained on a daily basis. However, if not maintained adequately they may fail on

²¹⁰ *Id.*

²¹¹ 2004 ADAAG (36 CFR part 1191, appendices B and D, adopted as part of both the Title II and Title III 2010 Standards), Advisory 105.2.3,

both safety and accessibility.²¹² Other products are designed specifically with accessibility in mind, but require greater capital outlays (though with lower maintenance requirements).²¹³

In 2010, the DOJ instituted a final rule to amend its implementing regulations of title II of the ADA.²¹⁴ Changes include adoption of a two-tiered approach to mobility devices, drawing distinctions between wheelchairs and “other power-driven mobility devices,” such as Segways. These changes may have an impact on parks and trails.

The 2010 regulations are particularly relevant to parks and recreation, and include recreational boating facilities; exercise machines and equipment; fishing piers and platforms; golf facilities; miniature golf facilities; play areas; saunas and steam rooms; and swimming pools, wading pools, and spas.²¹⁵ However, these primarily address new construction and renovation standards, and they do not alter the general program access framework.

On March 15, 2012, the DOJ delayed the required date for covered entities such as the City to install lifts in swimming pools.²¹⁶ The initial delay extended the effective date 60 days until May 20, 2012. At the same time, the DOJ indicated that it may extend the date for six

²¹² Mike Marshall, *Playground Surfacing Materials, ADA-Approved and Non-Approved*. Available at: https://www.ncemch.org/child-care-health-consultants/Part2/2-4_playground_surfacing.pdf.

²¹³ *Id.*

²¹⁴ *Nondiscrimination on the Basis of Disability in State and Local Government Services*, U. S. Department of Justice, RIN 1190-AA46, 75 Fed. Reg. 56164 (Sept. 15, 2010) (“2010 DOJ ADA Regulations”). Available at: <http://www.gpo.gov/fdsys/pkg/FR-2010-09-15/pdf/2010-21821.pdf>.

²¹⁵ 2010 DOJ ADA Regulations, 75 Fed. Reg. at 56180.

²¹⁶ *Nondiscrimination on the Basis of Disability by Public Accommodations and in Commercial Facilities; Swimming Pools*, U. S. Department of Justice, RIN 1190-AA46, 75 Fed. Reg. 56164 (Sept. 15, 2010) (“2010 DOJ ADA Regulations”). Available at: <https://www.federalregister.gov/articles/2012/03/20/2012-6748/nondiscrimination-on-the-basis-of-disability-by-public-accommodations-and-in-commercial-facilities>.

months. However, in the end, the DOJ extended the compliance date for one year until January 31, 2013, for both title II and title III entities to install fixed pool lifts in accordance with the 2010 ADA Standards.²¹⁷ The final extension of the rule states that the “2010 Standards apply whenever public entities choose to meet their title II ADA program accessibility obligations by making structural alterations to their existing facilities, 28 CFR 35.150(b)(1).”²¹⁸

Department of Interior (DOI) has been designated by regulation as the federal agency with authority to interpret Title II access to golf courses.²¹⁹ For over a decade, DOI has informed the public that a public golf course that provides golf cars on a rental basis must also make accessible golf cars available for rent, stating that the provisions of accessible golf cars is a required reasonable modification.

II. Sioux Falls Compliance

The Sioux Falls Parks and Recreation (SFPR) system consists of 3,346 acres of parkland, made up of 80 parks, 13 undeveloped sites, 3 support sites, 3 golf courses, and 5 community centers. Also included has been an expanding bike trail system of developed paths.

A. Neighborhood Parks

SFPR instituted substantial changes since the implementation of the ADA. As a result of prior self-evaluations and development plans, existing parks have been renovated to add

²¹⁷ *Amendment of Americans with Disabilities Act Title II and Title III Regulations to Extend Compliance Date for Certain Requirements Related to Existing Pools and Spas Provided by State and Local Governments and by Public Accommodations*. U. S. Department of Justice, RIN 1190-AA69, (May 20, 2012) (“2012 DOJ ADA Pool Regulation”). Available at: <https://www.federalregister.gov/documents/2012/05/21/2012-12365/amendment-of-americans-with-disabilities-act-title-ii-and-title-iii-regulations-to-extend-compliance>.

²¹⁸ *Id.* at 3-4.

²¹⁹ See 28 CFR 35:190(b)(5).

accessibility features. Many parks have been substantially renovated as part of the Department's overall capital improvement plan and have been built in compliance with the ADA and guidelines in place at the time.

SFPR has generally followed prior recommendations in the transition plans for existing playing fields to make 50% of each type of playing field at each park accessible, served by an accessible route and with an accessible viewing area. At parks where greater than 50% of the fields could easily be made accessible, the greater percentage was recommended. Accessible features include accessible routes to fields, accessible seating areas, accessible parking, and accessible playground structures. Parks substantially renovated since the ADA have been constructed with all fields and other elements accessible.

The authors visited approximately ten parks in 2011-2015 (some new or completely renovated) and confirmed general accessibility compliance at existing parks where various access features had been added to accomplish program accessibility. The only observed problems at existing facilities concerned: (1) poorly maintained wood chips at one park underneath playground structures, and (2) an inaccessible bathroom at Falls Park (although there were other bathrooms down the hill in the new main park building).

The Parks Department updated its transition plan in 2017.²²⁰ This project included a detailed review of the current state of access at the parks, detailed what parks will be addressed in the future, documented parks that are not planned for retrofit (but where nearby

²²⁰ See Appendix 6, Sioux Falls 2017 Updated Parks Department Transition Plan and Selected Documents.

facilities provide opportunities to “relocate” activities), and a 5-year capitol program to continue to maintain and improve parks, including a dedicated ADA retrofit budget.

B. Pools

There are seven aquatic facilities. Four of the pools have sloped entry, “zero depth” pools, specially designed to permit persons in wheelchairs to roll into the water and swim without special assistance.²²¹ The Midco Aquatic Center has lifts for the pools in addition to a sloped entry pool and a ramped entry therapy pool. The support facilities at these sites such as changing rooms, showers, rest rooms, and concessions are also accessible.

All aquatic programs offered by the City are available at these centers. Per prior studies, the City has deferred making substantial changes to the older pools until major renovation is contemplated.²²² The 2010 Standards, as modified by subsequent changes, do not appear to require SFPR to add lifts to the inaccessible pools as a required modification.

C. Golf

SFPR has three golf courses. All three of these are largely accessible. Landscapes Unlimited has a contract with the City to provide visitor services and grounds maintenance at the City’s three golf courses.²²³ There are no accessible golf carts, but SFPR is actively looking to resolve this. In the interim, SFPR will temporarily obtain an accessible golf cart on prior request.

D. Great Plains Zoo

²²¹ Spellerberg Park pool replaced as part of a \$24 million renovation in 2016. *Id.* at p. 2.

²²² See Appendix 7, Parks ADA Standard Operating Procedures, Nov. 1, 2003.

²²³ The 2003 transition report listed poor communication related training at the golf facilities and advised that the City and SFPR better manage the contractor. SFPR should continue to keep this in mind.

Chapter 4 - - Parks and Recreation

This facility houses specialized programming and public exhibits, all within the scope of a public zoo. Programming includes live animal exhibits in open natural settings accessible from a network of accessible hard pathways throughout the site, a nature museum housed within the main Zoo building, and gift shop and concessions housed in the main Zoo building. Zoo staff receive training in the proper procedures for serving the needs of persons with disabilities. A formal ADA policy and procedural manual was created. Readily achievable modifications identified in the 1998 transition review were implemented, improving parking, counter heights, and signage.

E. Great Bear Recreation Park

Great Bear Recreation Park has served as a downhill and cross-country ski area for some time in the community, and was later developed as an all season park and recreational area. The existing chalet was renovated approximately 2000. Specifications for this renovation were designed in accordance with ADA accessibility guidelines, and it was intended that construction will culminate in a fully accessible facility, which it is.

F. Family Park

Family Park is a newly constructed park surrounding a lake with accessible paths and docks. In response to a request for accommodation, SFPR worked with state fish and game to allow electric trolling motors to be used to accommodate a fisherman with disabilities.

G. Great Bear Archery Range

The City has provided approximately 30 acres at Great Bear Recreation Park for Minnehaha Archers Incorporated to construct and maintain an archery range that is accessible

to the general public. There are targets available at the ADA-compliant practice range and targets in place on the field range.

H. Bike Trail System

SFPR has been developing an expansive bike trail system throughout Sioux Falls. SFPR has been developing these paths in an accessible manner. SFPR continues to work on marking the trails to notify users of slope and other issues that make some of the sections of the trail inaccessible. Alternative routes options are provided.

SFPR has developed policies to allow “Other Power-Driven Mobility Devices” (OPDMDs, e.g., Segways) to use the trails (where other powered devices are prohibited from the bike paths).²²⁴ Under the policy, power wheelchairs are permitted on all trails (although some segments, particularly those designed for hikers or mountain bikes may be impassable) and electric-only OPDMDs are allowed only on Class I and II trails.

I. Parks and Recreation Policies

The SFPR is advised by a board that recommends capital projects including accessibility issues. SFPR has been proactive in developing its expansive park system and has increased accessibility as a side benefit (and intended result). SFPR works with third parties seeking to host events in the parks to ensure that access issues are addressed in the event planning stage.²²⁵

²²⁴ Appendix 7, *City of Sioux Falls Parks and Recreation Policies and Guidelines, 2020, Attachment 10, Sioux Falls Parks and Recreation’s Policy on Other Power Driven Mobility Devices (OPDMDs)*.

²²⁵ See Appendix 7, *Sioux Falls Parks ADA Standard Operating Procedures*, Nov. 1, 2003.

J. Recommendations

There are issues at some parks where there is not connectivity between accessible components. SFPR is aware of this issue and seeks to address it in future capital projects in its master plan.

The SFPR should consider compiling and publishing a list of accessible facilities. Currently, one has to read descriptions on each park individually to see what is available. If a resident wanted to engage in a particular activity at an accessible location, it might be challenging to find the right park for it.

**Chapter 5 –
Administrative
Requirements and
ADA Coordinator**

I. Federal Requirements

DOJ guidelines require title II entities like Sioux Falls to comply with a number of administrative requirements that ensure government entities do not discriminate against people with disabilities. These include having an ADA Coordinator, a complaint process, and that title II entities conduct self-evaluations.

Specifically, the City and SAM are required:

- to conduct a self-evaluation of its services, policies, and practices by July 26, 1992, and make modifications necessary to comply with the Department’s title II regulation, 28 C.F.R. §35.105;
- to notify applicants, participants, beneficiaries, and other interested persons of their rights and the City’s obligations under title II and the Department’s regulation, 28 C.F.R. §35.106;
- to designate a responsible employee to coordinate its efforts to comply with and carry out the City’s ADA responsibilities, 28 C.F.R. §35.107(a);
- to establish a grievance procedure for resolving complaints of violations of title II, 28 C.F.R. §35.107(b);
- to operate each program, service, or activity so that, when viewed in its entirety, it is readily accessible to and usable by individuals with disabilities, 28 C.F.R. §§35.149 - 35.150, by:
- delivery of services, programs, or activities in alternate ways, including, for example, redesign of equipment, reassignment of services, assignment of aides,

**Chapter 5 -
Administrative
Requirements and
ADA Coordinator**

home visits, or other methods of compliance or, if these methods are not effective in making the programs accessible,

- physical changes to buildings (required to have been made by January 26, 1995), in accordance with the Department's title II regulation, 28 C.F.R. §§35.150 and 35.151, and the 1991 ADA Standards for Accessible Design (Standards), 28 C.F.R. pt. 36, App. D (2011), or the Uniform Federal Accessibility Standards (UFAS), 41 C.F.R. §101-19.6, App. A.
- to ensure that facilities for which construction or alteration was begun after January 26, 1992, are readily accessible to and usable by people with disabilities, in accordance with 1) the Department's title II regulation and 2) the Standards, UFAS, or 2010 Standards, as applicable, 28 C.F.R. §35.151;
- to ensure that communications with applicants, participants, and members of the public with disabilities are as effective as communications with others, including furnishing auxiliary aids and services when necessary, 28 C.F.R. §35.160;
- to provide direct access via TTY (text telephone) or computer-to-telephone emergency services, including 9-1-1 services, for persons who use TTYs, 28 C.F.R. §35.162;
- to provide information for interested persons with disabilities concerning the existence and location of the City's accessible services, activities, and facilities, 28 C.F.R. §35.163(a); and,
- to provide signage at all inaccessible entrances to each of its facilities, directing users to an accessible entrance or to information about accessible facilities, 28 C.F.R. §35.163(b).

II. Sioux Falls Compliance

The City has enacted a series of Executive Orders to ensure compliance with the ADA.²²⁶ These orders cover: (1) Nondiscrimination and Anti-harassment, (2) Reasonable Accommodations, (3) ADA Review of New Construction, Remodels, and Retrofits of City Facilities and Parks, and (4) designation of an ADA Coordinator.

The City has an ADA Coordinator whose portfolio includes responsibilities related to all other aspects of government.²²⁷ The City ADA Coordinator has responsibility to address issues related to disability, including coordinating compliance efforts, overseeing grievance procedures, and development of the City's ADA Transition Plan. The ADA Coordinator ensures the City operates under rules governing nondiscrimination on the basis of disability in local government services, including investigation of complaints arising out of allegations that local government has failed to comply with the ADA.

The ADA Coordinator is a liaison for the City to outside disability organizations. The Disability Awareness and Accessibility Review Board is an extension of the Human Relations Commission and works toward improved access for people with disabilities. It acts as an advisory body to the City ADA Coordinator.²²⁸ The Board includes people with disabilities.

²²⁶ See Sioux Falls Executive Orders, attached as Appendix 8.

²²⁷ See ADA Coordinator description on the City's website, available at: <https://www.siouxfalls.org/city-attorney/relations/ada-coordinator>.

²²⁸ See Disability Awareness and Accessibility Review Board description on the City's website, available at: <https://www.siouxfalls.org/mayor/boards-commissions/disability-awareness-accessibility-review-board>. The authors met with the Board to discuss issues and the process for development of transition plans August 23, 2011.

**Chapter 5 -
Administrative
Requirements and
ADA Coordinator**

All employees are informed of the City's non-discrimination and reasonable accommodation policies, and the ADA Coordinator conducts training on this subject as part of all new employees' training. The ADA Coordinator and others conduct additional, in-depth training on these topics for employees in leadership roles

The City has a complaint procedure for complaints of disability discrimination. Sioux Falls City Ordinance Chapter 98.001 prohibits discrimination on the basis of race, color, creed, religion, sex, national origin, ancestry, disability, or familial status. Complaints are handled by the City Human Relations Commission, which enforces the law by investigating allegations of illegal discrimination. "It may order compensatory damages, reasonable accommodations and modifications, affirmative action, hiring, reinstatement, promotion, posting of EEO notices, etc."²²⁹

People with disabilities and groups representing people with disabilities are regularly engaged with evaluating new construction, retrofits, and other issues and polices through the Disability Awareness and Accessibility Review Board (previously the ADA Accessibility Review Board).²³⁰

²²⁹ See About the Commission on Human Relations. Available at <https://www.siouxfalls.org/mayor/boards-commissions/human-relations-comm/about>.

²³⁰ The City has had two boards addressing disability: the Disability Awareness Commission and the ADA Accessibility Review Board. These were combined into the Disability Awareness and Accessibility Review Board. See <https://www.siouxfalls.org/mayor/boards-commissions/disability-awareness-accessibility-review-board..>

**Chapter 5 -
Administrative
Requirements and
ADA Coordinator**

The City requires all entities using City facilities for activities open to the public to follow published procedures to ensure accessibility. These might apply, for example, at City parks, Washington Pavilion, and the Convention Center.²³¹

²³¹ See *Special Event Accessibility Planning*. Available at:
http://siouxfalls.org/~media/Documents/relations/Special_Events.pdf.

**Chapter 6 –
Effective
Communications &
Technology**

I. Federal Requirements

As noted, the ADA and other federal statutes require state and local governments to take steps to ensure that their communications with people with disabilities are as effective as communications with others, and to provide accessibility in technology on which the City requires. These requirements apply to the City’s phone systems, cable TV channel and web sites, in addition to in-person communications.

Public entities are required:

- to ensure that communications with applicants, participants, and members of the public with disabilities are as effective as communications with others, including furnishing auxiliary aids and services when necessary;²³²
- to provide an opportunity for individuals with disabilities to request the auxiliary aids and services of their choice and give this expressed choice primary consideration by the public entity;²³³
- to use text telephones (TTYs) or equally effective telecommunications systems to communicate with individuals who are deaf or hard of hearing or have speech impairments, and shall respond to telephone calls from a telecommunications relay service established under title IV of the ADA in the same manner that it responds to other telephone calls;²³⁴

²³² 28 C.F.R. §35.160.

²³³ 28 C.F.R. § 35.160(b)(2).

²³⁴ 28 C.F.R. §35.161.

**Chapter 6 -
Effective
Communications
& Technology**

- to provide direct access via TTY (text telephone) or computer-to-telephone emergency services, including 9-1-1 services, for persons who use TTYs.²³⁵

The 2010 DOJ regulations clarify procedures and requirements to ensure effective communication is available. “The type of auxiliary aid or service necessary to ensure effective communication will vary in accordance with the method of communication used by the individual; the nature, length, and complexity of the communication involved; and the context in which the communication is taking place.”²³⁶ “In order to be effective, auxiliary aids and services must be provided in accessible formats, in a timely manner, and in such a way as to protect the privacy and independence of the individual with a disability.”²³⁷

The revised regulations clarify that public entities shall not require an individual to bring someone to interpret, but may rely on such a person where the person with a disability so requests.²³⁸ Public entities may not rely on children to interpret except in emergencies. Finally, the 2010 DOJ regulations establish minimum technical standards for video remote interpreting (VRI) services.²³⁹

In addition to title II requirements, Federal Communications Commission (FCC) rules require broadcasters and cable operators to make local emergency information accessible to

²³⁵ 28 C.F.R. §35.162.

²³⁶ 28 C.F.R. §35.160(b)(2).

²³⁷ *Id.*

²³⁸ 28 C.F.R. §35.160(c).

²³⁹ 28 C.F.R. §35.160(d).

persons who are deaf or hard of hearing, and to persons who are blind or have visual disabilities. This rule means that emergency information must be provided aurally and in a visual format.

The ADA requires government websites to be accessible.²⁴⁰ The DOJ has been taking this position for some time in Project Civic Access settlements and elsewhere. For several years, DOJ Project Civic Access settlement agreements have required local government websites be accessible, though the technical standards have not detailed particular standards.²⁴¹

As mentioned, the DOJ has withdrawn prior steps toward formalizing such requirements. In an Advance Notice of Public Rulemaking (ANPRM), again now withdrawn as cited earlier, the DOJ summarized its view at that time that the ADA and Section 504 require accessibility in governments' websites as follows:

There is no doubt that the websites of state and local government entities are covered by title II of the ADA. *See* 28 C.F.R. 35.102 (providing that the title II regulation “applies to all services, programs, and activities provided or made available by public entities”). Similarly, there seems to be little debate that the websites of recipients of federal financial assistance are covered by section 504 of the Rehabilitation Act. The Department has affirmed the application of these statutes to websites in a technical assistance publication, *Accessibility of State and Local Government Websites to People with Disabilities* (available at: <https://www.ada.gov/websites2.htm>), and in numerous agreements with State and local governments and recipients of Federal financial assistance.²⁴²

²⁴⁰ See generally Peter Blanck, *eQuality: The Struggle for Web Accessibility by Persons with Cognitive Disabilities* (Cambridge University Press 2014).

²⁴¹ See, e.g., DOJ Project Civil Access settlement agreement with Kansas City, Missouri, dated July 25, 2012. Available at: http://www.ada.gov/Kansas_city_pca/kansas_city_pca_sa.htm.

²⁴² *Nondiscrimination on the Basis of Disability; Accessibility of Web Information and Services of State and Local Government Entities and Public Accommodations*, U.S. Department of Justice (DOJ Proposed Web Regulation), (RIN

Chapter 6 - Effective Communications & Technology

While the Web ANPRM has been withdrawn, DOJ has taken the position that the ADA generally requires website accessibility. (The DOJ notes that perhaps a city may attempt to meet its obligations where it has inaccessible website by having an accessible alternative such as a staffed phone line, but that such attempts are unlikely to provide equal access 24 hours a day, seven days a week.)²⁴³ The DOJ has been addressing other information technologies made available to the public at libraries and universities. (See discussion in Chapter 11, Libraries.)

This requirement applies to both the City's and SAM's websites, though there may be minor differences in how this obligation is imposed and whether a particular format is required. As the DOT observed in a 2011 regulatory filing, transit providers' primary obligations are to DOT, not DOJ regulations. The DOT has deferred instituting a general regulatory requirement on web accessibility. Nevertheless, the DOT observed that "under existing rules a transportation entity has an obligation to provide effective communication to persons with disabilities."²⁴⁴ This may include providing an accessible website or, if information is provided on an inaccessible site, then to provide the information through other equally effective means.

1190-AA61; 75 Fed. Reg. 43460, 43464 (July 26, 2010)). Available at:
http://www.ada.gov/anprm2010/web%20anprm_2010.htm.

²⁴³ See *Accessibility of State and Local Government Websites to People with Disabilities*. Available at:
<http://www.ada.gov/websites2.htm>.

²⁴⁴ *Transportation for Individuals with Disabilities at Intercity, Commuter, and High Speed Passenger Railroad Station Platforms; Miscellaneous Amendments*, U.S. Department of Transportation, RIN 2105-AD54. 76 Fed. Reg. 57924, 57931-57932 (amending 49 CFR Parts 37 and 38) (Sept. 19, 2011).

**Chapter 6 -
Effective
Communications
& Technology**

Federal law and regulations are moving towards, if not currently actually requiring, captioning of videos posted on websites. In *National Association of the Deaf v Netflix, Inc.*,²⁴⁵ the Federal Court denied Netflix's motion for Judgment on the pleadings in a complaint for failure to provide equal access to the Netflix video streaming website, "Watch Instantly," for deaf and hearing impaired individuals pursuant to Title III of the ADA.

The court held that the Internet is a "place of public accommodation," a term it found was not restricted to physical places. The court did state that Netflix may be able to demonstrate that it does not "control" the content sufficiently to provide closed captioning due to copyright issues, but the court merely invited the parties to revisit that issue in a later stage of the litigation. While Netflix succeeded in having the similar case in California dismissed, it entered into a consent decree with NAD and provided captioning of its online delivered content.

Likewise, the Ninth Circuit U.S. Court of Appeals in *Robles v. Domino's Pizza, LLC*,²⁴⁶ found the ADA title III mandates that places of public accommodation, like Domino's, "provide auxiliary aids and services to make visual materials available to individuals who are blind" [and] [t]his requirement applies to Domino's website and app, even though customers predominantly access them away from the physical restaurant."

²⁴⁵ *National Association of the Deaf v Netflix, Inc.*, 869 F.Supp.2d 196 (D. Mass. 2012). But see *Cullen v. Netflix, Inc.*, 880 F.Supp.2d 1017 (N.D. Cal. 2012), where the Court ruled in line with Ninth Circuit precedent that web sites are not places of public accommodation.

²⁴⁶ 913 F.3d 898, 905 (9th Cir. 2019), *cert denied* 140 S.Ct. 122 (2019).

II. Sioux Falls Compliance

The City has identified sources of qualified sign language and oral interpreters, and these services are available 24 hours per day, 365 days per year. The City has a standing contract with InterpreCorps, LLC to provide sign language translators.²⁴⁷ The City provides sign language interpreters several times a year at events at the request of individuals or businesses.²⁴⁸ The City Council has assistive listening devices in the chambers and recently implemented a live closed caption technology that is displayed on multiple screens. The City no longer has a braille printer. It can get documents printed in braille by Pheasant Land Industries, and it can produce braille documents upon request.²⁴⁹ The City has provided personnel to give direction and provide braille documents at public events.²⁵⁰

City 911 services are coordinated through Minnehaha County, and the Minnehaha County service is equipped with a working TTY. City Hall and the Sioux Falls Police Department police station have working TTY equipment. The City relies on and accepts relay services and has trained personnel in their use.

The City has created a 211 helpline call-in number for information related to certain City services, including emergency information, paratransit, and other information.²⁵¹ We note that

²⁴⁷ Appendix 9, Interpreters, Inc. Contract.

²⁴⁸ Communication with Colleen Moran, former ADA Coordinator.

²⁴⁹ Communication with Daniel Hagggar, ADA Coordinator.

²⁵⁰ Communication with Colleen Moran, former ADA Coordinator.

²⁵¹ Appendix 10, 211 Contract.

**Chapter 6 -
Effective
Communications
& Technology**

the contract, while it has basic language prohibiting discrimination, does not specify a requirement that the operator provide TTY access or coordinate and receive relay calls.

The City provides captioning for its City Council meetings and other addresses by the mayor.

The City's website is largely accessible, although a review has shown issues the City is working to address. The City's website was redesigned in 2012 and 2016. While we have not reviewed all pages, we have found that there are frequent minor errors. When viewed with a Lynx text browser, some pages were unwieldy and would benefit from manual examination. For example, images lack alternative text, the drop down list behaved strangely (perhaps because the order was undefined?), some text has inadequate contrast, and the search bar seems unlabeled on the Mayor's Office page at <https://www.siouxfalls.org/mayor>.²⁵² The City IT personnel are now using SiteImprove to monitor all web pages.

More significantly, much of the information is only available as individual PDF files, which are disfavored.²⁵³ The website would be more accessible if information were available in HTML format. Within a number of these downloaded files, PDF's are missing required tagging to simplify reading in text-only mode.²⁵⁴ A recent review of job notices indicates the City is

²⁵² See Sample Accessibility Report, Appendix 11.

²⁵³ *Accessibility of State and Local Government Websites to People with Disabilities*. Available at: <https://www.ada.gov/websites2.htm>.

²⁵⁴ See Sioux Falls City Council Audit Committee Agenda, September 28, 2020 (missing tags, reading order, primary language, and embedded titles). Available at https://amv.siouxfalls.org/OnBaseAgendaOnline/Documents/Downloadfile/Audit_Committee_Meeting_3051_Agenda_9_28_2020_4_00_00_PM.pdf?documentType=1&meetingId=3051.

improving their accessibility. They are converting more of these PDFs to HTML via SeamlessDocs.

The City hosts many video files on its site and some of these do not have captions.²⁵⁵ Captioning is possible on websites.²⁵⁶ Many of these appear to have been scripted and thus the text should be readily available. If captioning proves onerous, the City may provide links to alternative information sources. The City has improved this indirectly by hosting files to Youtube, which provides reasonable automatic closed captions.

For example, on the Ready-Set-Go video, the City may alternatively provide links to text documents describing emergency preparedness (elsewhere, the website does have links to an older document, *Taking Responsibility for Your Safety, Tips for People with Activity Limitations and Disabilities*²⁵⁷). While captioning on the website would be most effective, the City should ensure its communications provided by video are transmitted in some equally effective manner regardless of the mechanism.

As the City captions its content delivered via its television channel, it may be required to caption video distributed on its websites (where they are the same) under the Twenty-First Century Communications and Video Accessibility Act of 2010.²⁵⁸

²⁵⁵ See, e.g., Ready-Set-Go video describing emergency preparedness. Available on Emergency Management page at <https://www.siouxfalls.org/fire/emergency-management..>

²⁵⁶ See, e.g. <http://support.google.com/youtube/bin/answer.py?hl=en&answer=100079>.

²⁵⁷ https://www.siouxfalls.org/-/media/Documents/emergency_management/Tips-for-People.ashx (though this older PDF is missing effective current tagging for text-only mode).

²⁵⁸ Pub. L. No. 111-260, 124 Stat. 2751, § 202(b) (2010). See also Amendment of Twenty-First Century Communications and Video Accessibility Act of 2010, Pub. L. No. 111-265, 124 Stat. 2795 (2010) (making technical corrections to the CVAA).

III. Recommendations

The City's contract with InterpreCorps, LLC, does not contain specific details regarding time responses for interpreters, other than that the service shall provide interpreters "as needed." The City should consider clarifying its contract to ensure that interpreters are available within a given period of time to ensure services are available in a reasonable time.

The City should clarify responsibilities in its 211 helpline contract. While it has basic language prohibiting discrimination, it does not specify a requirement that the operator provide TTY access or coordinate and receive relay calls. The City should ensure that such services are provided if this is not the case.

The TTY number should be listed wherever the general phone number is listed.²⁵⁹ It used to be listed on the Human Resources page but no longer is, despite the fact that a phone number is listed. The TTY number should be listed similarly on the Fire and Police Department home web pages, under its phone number, where phone and fax numbers are listed. The one place I found where the TTY number is listed consistently is on the library pages.

After discussions with staff, City personnel are working to address the technical issues identified with the website. The City should communicate these requirements to personnel who produce written product that gets published on its website. IT staff in the central services department are technically proficient in making these changes, but, with the heavy use of

²⁵⁹ As the City has removed phone numbers from much of its web site, listing the TTY number might not technically be required as a result.

**Chapter 6 -
Effective
Communications
& Technology**

inaccessible PDF files, accessibility needs to be built into the document production process earlier. This should result in greater accessibility as well as more efficiency.

We did not perform an exhaustive audit of the City's website, but identified common or recurring issues. Personnel should continue to review and scrub the website. It may help to enlist the public, particularly those with disabilities, in this effort. As noted, while there is no required enforceable standard, we recommend the City strive towards WCAG 2.1 AA conformance. This will improve accessibility and mitigate the possibility of future litigation risk and costs to achieve compliance with a generally accepted standard. In addition, where the City hosts captioned content delivered via its television channel, it may be required to caption video distributed on its websites (where they are the same) under the Twenty-First Century Communications and Video Accessibility Act of 2010.²⁶⁰

²⁶⁰ Pub. L. No. 111-260, 124 Stat. 2751, § 202(b) (2010). See also Amendment of Twenty-First Century Communications and Video Accessibility Act of 2010, Pub. L. No. 111-265, 124 Stat. 2795 (2010) (making technical corrections to the CVAA).

I. Federal Requirements

Title I of the ADA requires employers with 15 or more employees (including governmental entities)²⁶¹ to provide qualified individuals with disabilities an equal opportunity to benefit from the full range of employment-related opportunities available to others.

For example, title I prohibits discrimination in recruitment, hiring, promotions, training, pay, social activities, and other privileges of employment. It restricts questions that may be asked about an applicant's disability before a job offer is made, and it requires that employers make reasonable accommodation to the known physical or mental limitations of otherwise qualified individuals with disabilities, unless it results in undue hardship.

Title I entities:

- will not discriminate on the basis of disability in its hiring or employment practices;
- will not ask a job applicant about the existence, nature, or severity of a disability. Applicants may be asked about their ability to perform specific job functions. Medical examinations or inquiries may be made, but only after a conditional offer of employment is made and only if required of all applicants for the position;

²⁶¹ In *Board of Trustees of the University of Alabama v. Garrett*, 531 U.S. 356 (2001), the Supreme Court ruled that title I of the ADA was unconstitutional insofar as it allowed states to be sued by private citizens for money damages. The *Garrett* decision only prohibited title I suits against state governments, not cities or counties, because sovereign immunity as embodied in the Eleventh Amendment does not apply to local governments.

**Chapter 7 -
Employment and
Human Relations
Department**

- will make reasonable accommodations for the known physical or mental limitations of a qualified applicant or employee with a disability upon request unless the accommodation would cause an undue hardship on the operation of the City’s business. If an applicant or an employee requests a reasonable accommodation and the individual's disability and need for the accommodation are not readily apparent or otherwise known, the City may ask the individual for information necessary to determine if the individual has a disability-related need for the accommodation;
- will maintain an employee’s medical records separate from personnel files and keep them confidential; and
- will make an individualized assessment of whether a qualified individual with a disability meets selection criteria for employment decisions. To the extent the City’s selection criteria have the effect of disqualifying an individual because of disability, those criteria must be job-related and consistent with business necessity.

In 2008, Congress passed the Americans with Disabilities Act Amendments Act (ADAAA), and it became effective on January 1, 2009.²⁶² The law made a number of changes to the definition of “disability” under the ADA. It directed the U.S. Equal Employment Opportunity Commission (EEOC) to amend its ADA regulations to reflect the changes made by the ADAAA. The EEOC issued a Notice of Proposed Rulemaking (NPRM) on September 23, 2009. The final

²⁶² ADAAA, 42 U.S.C.A. § 12101.

regulations were approved by a bipartisan vote and were published in the Federal Register on March 25, 2011.²⁶³

Congress passed the ADAAA to overturn several restrictive Supreme Court rulings, and the ADAAA states that the definition of disability should be interpreted in favor of broad coverage of individuals.²⁶⁴ Following the ADAAA, the regulations keep the ADA's definition of the term "disability" as a physical or mental impairment that substantially limits one or more major life activities; a record (or past history) of such an impairment; or being regarded as having a disability. But the regulations implement the significant changes that Congress made regarding how those terms should be interpreted.

The ADAAA regulations include the following:

- **The term "substantially limits" requires a lower degree of functional limitation than the standard previously applied by the courts.** An impairment does not need to prevent or severely or significantly restrict a major life activity to be considered "substantially limiting." Nonetheless, not every impairment will constitute a disability.
- **The term "substantially limits" is to be construed broadly** in favor of expansive coverage, to the maximum extent permitted by the terms of the ADA.
- The determination of whether an impairment substantially limits a major life activity **requires an individualized assessment**, as was true prior to the ADAAA.
- With one exception ("ordinary eyeglasses or contact lenses"), the determination of whether an impairment substantially limits a major life activity shall be made **without**

²⁶³ See Regulations to Implement the Equal Employment Provisions of the Americans with Disabilities Act, as Amended. 76 F.R. 16977 (amending 29 CFR 1630) (EEOC ADAAG Regulations). Available at: <https://federalregister.gov/a/2011-6056>.

²⁶⁴ See EEOC ADAAA Fact Sheet. Available at: http://www.eeoc.gov/laws/regulations/adaaa_fact_sheet.cfm.

regard to the ameliorative effects of mitigating measures, such as medication or hearing aids.

- **An impairment that is episodic or in remission is a disability** if it would substantially limit a major life activity when active.
- In keeping with Congress’s direction that the primary focus of the ADA is on whether discrimination occurred, **the determination of disability should not require extensive analysis.**²⁶⁵

There have been relatively few federal cases brought enforcing the ADA (under the ADAAA) against state or municipal entities, however, there have been compliance agreements reached.

Recently, the EEOC has published pages to consolidate relevant coronavirus and COVID-19 information and answer questions from the public about the EEO laws and COVID-19.²⁶⁶

II. Sioux Falls Compliance

Sioux Falls has instituted policies to ensure compliance with the ADA’s employment non-discrimination requirements.²⁶⁷ Employees are informed of the City’s non-discrimination and reasonable accommodation policies, and new employees and those promoted receive

²⁶⁵ *Id.*

²⁶⁶ See EEOC, *Coronavirus and COVID-19* (April 9, 2020). Available at <https://www.eeoc.gov/coronavirus/>. And see EEOC, *What You Should Know About COVID-19 and the ADA, the Rehabilitation Act, and Other EEO Laws, Technical Assistance Questions and Answers - Updated on Sep. 8, 2020*. Available at <https://www.eeoc.gov/wysk/what-you-should-know-about-covid-19-and-ada-rehabilitation-act-and-other-eeo-laws>.

²⁶⁷ See Sioux Falls Executive Orders and Policies Regarding Disability, Appendix 8.

**Chapter 7 -
Employment and
Human Relations
Department**

training conducted by the City ADA Coordinator, amongst others.²⁶⁸ Department administrators can arrange additional training. In addition, the City has adopted an affirmative action plan, updated annually, that includes employee self-reported disability status. Per the Affirmative Action Plan for plan year 2020, the City meets or exceeds the 7% goal for employing individuals with disabilities in all of its EEO job categories.²⁶⁹

The City HR and ADA Coordinator have done training on the ADAAA's requirements. The City should ensure that changes due to the ADAAA are integrated. Although we have seen no reports that the City has challenged whether complainants are "disabled," the ADAAA does not in essence change the City's responsibilities in a practical manner.

Accommodations may be accomplished informally within a department and are typically made with the assistance of the ADA Coordinator. If an accommodation is denied, or an employee claims other discrimination based on disability or another protected status, a claim can be brought.

The City has provided various accommodations to employees. For example, Falls Community Health has:

- Provided and an accessible mouse for a staff member with limited dexterity;
- Provided a monitor "reader" for a staff member with limited eyesight; and,
- Conducted an ADA review and office accommodation for a staff member who uses a wheelchair.

²⁶⁸ Conversation with Daniel Haggar, ADA Coordinator.

²⁶⁹ Conversation with Jane Hannestad, Human Resources Manager, Aug. 20, 2020.

**Chapter 7 -
Employment and
Human Relations
Department**

The City is processing accommodation requests due to concerns about Covid-19 for employees returning to work.²⁷⁰

The City currently posts job announcements on its website. In 2015, these had access problems, as noted prior. The job announcements were posted as PDF files, which lack accessibility information making them difficult to navigate via text based and alternative browsers. The website itself was designed in such a way that logging-in, so as to be able to submit information, was technically challenging. In response to our advice at the time, the City's website redesign addressed these issues, and job postings are now functionally accessible.

The City includes functional job assessments which delineate the physical and other requirements of each job. This will allow the City and employees to have a clear understanding of requirements and may be part of a formal accommodation analysis for employees with disabilities. It also helps to address return-to-work and job performance requirements.

HR manages an employee assistance program. This program can assist employees to deal with secondary effect of disabilities, stress, trauma, or other issues.

HR has a well-being program and has considered issues of disability. The individual responsible for the wellness program has advised people with disabilities of alternative means

²⁷⁰ Conversation with ADA Coordinator and HR, Aug. 20, 2020.

of accomplishing wellness goals, tests delivered via alternative mechanisms, and other changes which allow people with disabilities to receive equal benefits from the program.²⁷¹

III. Recommendations

Broadly speaking, the City may consider strategies to direct employment notices to additional groups and organizations consisting of, or representing, people with disabilities to increase awareness of job openings.

²⁷¹ Meeting with HR personnel, Jan. 14, 2013 and conversation, Aug. 20, 2020.

Chapter 8 – Emergency Management

I. Federal Requirements

State and local governments act to protect residents and visitors from harm, including assistance in preparing for, responding to, and recovering from emergencies and disasters. “Sioux Falls COVID-19 Response” webpage has extensive resources.²⁷² This online response page will be considered below from the perspective of persons with disabilities and relevant City stakeholders.

Governmental entities are required to comply with their title II obligations in conducting emergency management and disaster recovery services, programs, and activities and must ensure that no qualified individual with a disability, on the basis of disability, be excluded from participation in or denied the equal benefits of the services, programs, and activities of a public entity, or face discrimination by any such an entity.²⁷³

Cities must ensure title II compliance with all aspects of emergency management, including planning, preparedness, evacuation, shelters, medical and social services, lodging and housing programs, recovery, and rebuilding. The federal government has not issued regulations defining specific requirements, but the DOJ has been relying on guidelines outlined in Chapter 7 of the DOJ’s *ADA Best Practices Tool Kit for State and Local Government* (DOJ ADA Emergency Tool Kit).²⁷⁴

²⁷² See <https://www.siouxfalls.org/covid19>.

²⁷³ 42 U.S.C. § 12132.

²⁷⁴ *DOJ ADA Best Practices Tool Kit for State and Local Government* (DOJ ADA Emergency Tool Kit). Available at: <http://www.ada.gov/pcatoolkit/chap7emergencymgmt.htm>.

The DOJ ADA best practices address:

- Preparation – advance planning for emergencies and disasters;
 - On an ongoing basis, seek and use input from people with different types of disabilities (i.e., mobility, vision, hearing, cognitive, psychiatric, and other disabilities) regarding all phases of the emergency management plan;
- Testing of Preparedness – staging emergency simulations and other approaches to testing the effectiveness of emergency preparedness;
 - Enlist people with disabilities to role-play during emergency simulations; seek and use input from people with a variety of disabilities, and organizations with expertise on disability issues;
- Notification – alerting the public to emergencies and disasters and to available programs, services, and activities;
 - Use a combination of notification methods to be more effective than relying on one method alone;
 - Combining visual and audible alerts will reach a greater audience than either method would alone;
 - Auto-dialed text telephone (TTY) messages to pre-registered individuals who are deaf or hard of hearing, text messaging, emails, and other innovative uses of technology may be incorporated into such procedures;
 - Provide qualified sign language interpreters and open captioning for announcements by government officials on local television stations,
 - The emergency management plan should identify the steps that will be taken and the resources that will be used to ensure that emergency notifications will be accessible to all;
- Community Evacuation and Transportation;

Chapter 8 - Emergency Management

- Establish procedures to ensure that people with disabilities can evacuate the area of an emergency in a variety of conditions, with assistance when it is needed (to account for communications, vision and mobility issues);
- One step that can significantly increase the effectiveness of the planning process is to create a voluntary, confidential registry of persons with disabilities who may need individualized notification or evacuation assistance (and ensure that it is voluntary and confidential);
- Because people with disabilities may not be able to drive or use traditional vehicles, identify accessible forms of transportation (i.e., vehicles equipped with wheelchair lifts) available to help evacuate people with disabilities;
- Emergency Shelter Programs;
 - Ensure shelters are accessible;²⁷⁵
 - Ensure people with disabilities can shelter with their families and other in mass care shelters and are not forced to shelter only in medical shelters;
 - Local governments and shelter operators may not make eligibility for mass care shelters dependent on a person's ability to bring his or her own personal care attendant;
 - Ensure adequate numbers of trained personnel are available;
 - Ensure people with disabilities are able to use appropriate bedding where standard cots are not otherwise appropriate;
 - Consider low-stimulation "stress-relief zones";
 - Provide an effective way for people to request and receive durable medical equipment and medication;
 - Whenever possible, provide refrigeration for certain types of medication;

²⁷⁵ See DOJ's ADA Best Practices Tool Kit for State and Local Government (ADA Tool Kit), Addendum 2. Available at: <http://www.ada.gov/pcatoolkit/chap7shelterprog.htm>. See also, ADA Checklist for Emergency Shelters, July 26, 2007. Available at: <http://www.ada.gov/pcatoolkit/chap7shelterchk.htm>.

Chapter 8 - Emergency Management

- Provide food options that allow people with dietary restrictions to eat, such as in the case of diabetes or food allergies;
 - If electricity is available, give priority to people with disabilities who use ventilators, suctioning devices, and other life-sustaining equipment, and where possible, ensure shelters have access to electric power from a generator or other source of electricity;²⁷⁶
- Temporary Lodging and Housing;
 - Emergency Medical Care and Services;
 - Social Services and Emergency and Disaster-Related Benefit Programs;
 - Relocation Programs, Activities, and Services;
 - Transition and Transportation Back to the Community Following an Emergency or Disaster;
 - Emergency and Disaster Recovery Programs, Services, and Activities; and,
 - Remediation of Damage Caused by Emergencies and Disasters– repairing and rebuilding damaged facilities, removing debris, and relocation and re-introduction of state and local government programs, services, and activities following an emergency or disaster.

In one case in California, the federal court granted summary judgment in favor of plaintiffs where the City of Los Angeles had failed to establish adequate emergency measures based on similar requirements for people with disabilities.²⁷⁷ This led to a settlement amongst the parties.

²⁷⁶ ADA Checklist for Emergency Shelters. Available at: <http://www.ada.gov/pcatoolkit/chap7shelterchk.htm>.

²⁷⁷ See *Communities Actively Living Independently and Free (CALIF), et al. v. City of Los Angeles*, No. 2:09-cv-00287-CBM –RZ, C.D. Ca. (Feb. 10, 2011). Available at: https://dralegal.org/wp-content/uploads/2012/09/order_0.pdf.

Chapter 8 - Emergency Management

In other cases where localities lacked emergency plans corresponding to the above DOJ outline, plaintiffs have obtained a settlement agreement,²⁷⁸ and in another, a federal judge found that New York City failed to (1) ensure that people with disabilities were able to evacuate before or during an emergency, (2) provide sufficiently accessible shelters and (3) inform people with disabilities of the availability and location of accessible shelters.²⁷⁹ New York City and the advocates settled the case in 2014 in accord with the Court's opinion.²⁸⁰

The Federal Emergency Management Agency (FEMA) provides similar planning guidance, particularly for shelters.²⁸¹ After Hurricane Katrina, and the disparities in access that became apparent in the aftermath, FEMA developed guidelines to buttress other shelter and emergency guidance and standards. Functional Needs Support Services (FNSS) are defined as services that enable individuals to maintain their independence in a general population shelter.

FNSS includes:

- reasonable modification to policies, practices, and procedures;
- durable medical equipment (DME);
- consumable medical supplies (CMS);

²⁷⁸ See *California Foundation for Independent Living Centers (CFILC), et al., v. City of Oakland* (2010). Available at: <http://www.dralegal.org/sites/dralegal.org/files/casefiles/settlementagreement.pdf>.

²⁷⁹ See Opinion and Order (after trial), *Brooklyn Center for Independence of the Disabled (BCID), et al. v. Mayor Bloomberg, et al.*, No. 1:11-cv-06690-JMF, E.D. N.Y. (Nov. 7, 2013). Available at: <http://www.nysd.uscourts.gov/cases/show.php?db=special&id=353>. See also <http://www.dralegal.org/bcid-v-bloomberg>.

²⁸⁰ See Settlement Agreement. Available at: <http://www.dralegal.org/sites/dralegal.org/files/casefiles/settlementstip.pdf>.

²⁸¹ Guidance on Planning for Integration of Functional Needs Support Services in General Population Shelters, FEMA. Nov. 2010 (FEMA FNSS Guidance). Available at: http://www.fema.gov/pdf/about/odc/fnss_guidance.pdf.

- personal assistance services (PAS); and,
- other goods and services as needed.

Under the FNSS rubric, FEMA emphasizes planning for FNSS needs to be available at general shelters:

Often, it is assumed that during a disaster, children and adults requiring FNSS must be housed in a medical special needs shelter. Children and adults with access and functional needs do not necessarily have medical conditions and typically do not require the care that medical shelters provide. Diverting to medical shelters can result in the separation of individuals with disabilities from those associated with them such as family, friends, neighbors and caregivers. In addition, inappropriate placement can jeopardize the health and safety of the entire community by creating unnecessary surges on emergency medical resources.²⁸²

Whether viewed under the DOJ or FEMA FNSS guidelines, preparations should be focused for the majority of people with disabilities to shelter at general shelters, not medical or other special needs shelters. To accomplish this, “emergency managers and shelter planners should collaborate with all relevant stakeholders including:

- People requiring FNSS;
- Agencies and organizations that provide FNSS;
- Agencies and organizations that advocate for the rights of people requiring FNSS; and,
- DME, CMS, PAS, and communication providers.”²⁸³

²⁸² FEMA FNSS Guidance at 15.

²⁸³ *Id.* at 16.

In addition to title II requirements, Federal Communications Commission (FCC) rules require broadcasters and cable operators to make local emergency information accessible to persons who are deaf or hard of hearing, and to persons who are blind or have visual disabilities. This rule means that emergency information must be provided both aurally and in a visual format.²⁸⁴

We expect new issues to come to light with COVID-19's progression.²⁸⁵ The City should continue to evaluate issues that arise, and keep abreast of new federal guidance.

II. Sioux Falls Compliance

A. Planning

The Office of Emergency Management, working in conjunction with City departments and other regional government and non-governmental organizations, has produced substantial emergency management plans.²⁸⁶ The plans call for the City to have primary immediate responsibility in the event of an emergency or natural disaster, and then, if the event is beyond the City's resource capability, to work with assistance from surrounding counties, the state, and federal resources.²⁸⁷

²⁸⁴ See <https://www.fcc.gov/file/15296/download>.

²⁸⁵ See *OCR Issues Bulletin on Civil Rights Laws and HIPAA Flexibilities that Apply During the COVID-19 Emergency*. Available at <https://www.hhs.gov/about/news/2020/03/28/ocr-issues-bulletin-on-civil-rights-laws-and-hipaa-flexibilities-that-apply-during-the-covid-19-emergency.html>. Full notice available at <https://www.hhs.gov/sites/default/files/ocr-bulletin-3-28-20.pdf>.

²⁸⁶ See *City of Sioux Falls Emergency Operations Plan*. Available at: http://www.siouxfalls.org/~media/Documents/emergency_management/EO%20Plan.pdf.

²⁸⁷ *Id.* at 4.

Chapter 8 - Emergency Management

The City coordinates pre-emergency planning, emergency response, and recovery operations by City personnel, assisting entities, and volunteers and other private parties.²⁸⁸ The City Multi-Coordination Team (MACT) and the City/County Emergency Preparedness Network (e.g., city, county, state, federal government, hospitals, volunteer agencies, utility providers) meet every other month to coordinate disaster response activities, training, exercises and resources.²⁸⁹ The City ADA Coordinator is a part of this group. The City has joined with other counties and regional partners as part of a plan for broader regional response in the event of larger emergency, mass casualty incidents.

The planning addresses people with disabilities at various levels. The Emergency Operations Plan notes:

There are people with special needs at risk in Sioux Falls. This population will require special considerations in warning, evacuation, and other areas of emergency/disaster response.²⁹⁰

The City works with the Sioux Falls Healthcare Coalition (SF Department of Health, Avera McKennan Hospital and University Center, Avera Heart Hospital of South Dakota, LifeScape, Sanford USD Medical Center and Hospital, Sioux Falls Surgical Center and the Veteran's Administration Medical Center) to lead preparedness efforts for sustained medical care for special needs populations through case management and outreach services as well as through

²⁸⁸ *Id.* at 9-10.

²⁸⁹ See *Emergency Preparedness Efforts for those with Disabilities*. Appendix 12.

²⁹⁰ Emergency Operations Plan at 4.

Chapter 8 - Emergency Management

home health programs. The City and regional partners have developed emergency planning maps that identify hospitals, group homes, assisted living centers, residential living centers, nursing homes, incarceration, and daycare centers.²⁹¹

In 2010, the City worked with local healthcare providers and the Red Cross to identify homebound citizens that lived in flood-prone areas to be prepared to provide assistance in evacuations if the river levels overtopped the city's levee system. The City and regional partners have created a contact list identifying individuals, community based organizations and other agencies that support at-risk/special needs populations.²⁹² This list is used in planning and to contact community based organizations before and during an emergency. The City has contacted some of these organizations to encourage and educate them and those they represent in preparedness.²⁹³

The City has chosen not to engage in any type of pre-registration program that would allow individuals to identify particular notification or evacuation needs in the event of an emergency. According to the City Emergency Manager, the City believes such a program would not be reliable in that people would fail to update their needs and locations.²⁹⁴ It plans to assist evacuation by deploying trained teams through neighborhoods to ensure evacuation. This

²⁹¹ See Example Emergency Planning Maps Regarding Disability. Appendix 13.

²⁹² See *Emergency Planning: Region 3 At Risk Populations: Community Based Organizations*. Appendix 14.

²⁹³ Email communication with Regan Smith.

²⁹⁴ Meeting with Jim Sideras (Fire Chief); Regan Smith (Emergency Management); Sandy Frentz (Public Health Manager), August 29, 2012.

function was exercised during 2019 Flood Response during evacuation of a neighborhood in Southern Sioux Falls.

Plans assume that people may need to be self-sufficient for three (3) days. As part of preparation for people, the City and partners have created several publications for people with disabilities and other at-risk populations. It has held presentations for several groups where it has described the emergency plans and distributed these materials.²⁹⁵

B. Testing of Preparedness

The City has tested its responses at various times. These tests have included people with disabilities in several instances. In 2011, the community held Citywide functional and tabletop exercises in which a tornado-based scenario required the evacuation of residents and staff of LifeScape.²⁹⁶ In addition to testing communications and coordination between the facility and the City, patient tracking was tested along with citywide disaster support.

The City has been involved with healthcare, rehabilitation hospitals, and residential facilities as they conduct exercises that include the triage and transportation of people with disabilities to maintain CARF accreditation.²⁹⁷ A recent school evacuation and reunification exercise included students with disabilities and provided emergency personnel opportunity to

²⁹⁵ The City has distributed a document created for Los Angeles, June Isaacson Kailes, *Emergency Preparedness: Taking Responsibility for Your Safety, Tips for People with Access and Functional Needs Limitations*. Available at: http://espfocus.org/uploads/ESP_DisabiPlan-LACo_0410.pdf.

²⁹⁶ See *Emergency Preparedness Efforts for those with Disabilities*. Appendix 12.

²⁹⁷ Email communication with Regan Smith.

test their training and ability to work with people with disabilities.²⁹⁸ Avera Behavioral Health evacuated all patients during the 2019 Tornado Response.

The City experienced a large ice storm / power outage in April 2013 that impacted the community for several days. Even though power loss affected approximately 90,000 residents for several days, only 14 people utilized a public shelter.²⁹⁹ While utilization was low, it provided an opportunity to further evaluate capabilities.

C. Notification

In addition to distributing information through the national Emergency Alert System and the press (with Closed Captioning available via both), the City has several systems it intends to use for emergency notification and information. It has created a 211 helpline call-in number for information related to certain City services, including emergency information.³⁰⁰

The City of Sioux Falls utilizes the Everbridge Emergency Notification System to communicate to residents. The system is also used by Public Works and Vector Control as part of routine operations. The schools have information systems for subscribers. Public Works has a system that will send voicemails to account holders.

Finally, the City worked with Communication Services for the Deaf (CSD), the South Dakota Association of the Deaf and a private vendor to make specialized NOAA weather radios available to deaf and hard of hearing community members at a reduced cost. CSD has

²⁹⁸ Email communication with Regan Smith.

²⁹⁹ Email communication with Regan Smith.

³⁰⁰ See Appendix 10.

partnered with the City to serve as liaison to relay emergency information to the deaf and hard of hearing community through text message and email.

D. Community Evacuation and Transportation

The City controls the buses and paratransit buses used by SAM and has access to these in an emergency. In addition, the City has an Ambu-Bus conversion kit it can use to transfer large numbers of non-ambulatory patients in the event a hospital needs to be evacuated or there is a mass casualty event. The City plans to assist evacuation by deploying trained teams through neighborhoods to ensure evacuation.

E. Emergency Shelter Programs

The City does not currently have a formal contract with the Red Cross, but the City works with it as one of its partners. The Red Cross has identified 19 facilities to be used as possible shelter locations in Sioux Falls in the event a large number of persons need to be evacuated from their homes. The Red Cross and the City determined the sites to be accessible by using a Red Cross planning tool.³⁰¹

The City plans that only accessible facilities will be selected as shelters. The identified facilities are schools and community centers. Each site has refrigeration. There are no large public facilities with shelter capabilities within the community with full backup power. The City plans to bring in portable power to these other facilities, if necessary.³⁰² The City has accessible

³⁰¹ Email communication with Regan Smith.

³⁰² Email communication with Regan Smith.

cots available for all shelters. All shelters accept service animals (and the City has plans for other pets to be cared for separately).³⁰³

F. Emergency Medical Care and Services

The City works with the Sioux Falls Healthcare Coalition (SF Department of Health, Avera McKennan Hospital and University Center, Avera Heart Hospital of South Dakota, LifeScape, Sanford USD Medical Center and Hospital, Sioux Falls Surgical Center and the Veteran's Administration Medical Center) to lead preparedness efforts for sustained medical care for special needs populations through case management and outreach services as well as through home health programs.

G. Access to Other Issues

The City's Public Health Department has a partnership with the Sioux Falls Healthcare Coalition, an organization of the five (5) local hospitals and their affiliated nursing homes and home healthcare systems. This partnership provides access to available durable medical equipment locally.

In addition, the City participates in local, regional and statewide Healthcare Preparedness Planning. If durable medical equipment and medications are not available locally, the City has access to an established network to access supplies regionally as well as from

³⁰³ See Sioux Falls Animal Emergency Response Plan, p. 3, August, 2013. Appendix 15.

across the state. The South Dakota State Department of Health maintains a cache of medical supplies and medications that are available to help support emergency responses.³⁰⁴

During and after an emergency, the City utilizes what it terms a Volunteer and Donations Management Annex within its Emergency Operations Plan. That plan identifies assistance to victims and communications with all segments of the population. Following the 2013 ice storm, for example, the community unmet needs committee / Community Organizations Active in Disaster (COAD) assisted the elderly, those with disabilities, and low income citizens recover from the disaster.

H. Sioux Falls COVID-19 Response

Sioux Fall deploys a range of strategies to deal with COVID-19. The City set up shelters for homeless populations. It distributed information from national sources such as the Administration for Community Living and the National Alliance on Mental Illness on how COVID-19 impacts people with different disabilities.³⁰⁵ Facilities were able to continue dialysis. Otherwise, the City reports it did not notice identifiable issues affecting people with disabilities requiring additional attention at this time. The City should continue to evaluate issues that come to light with COVID-19's progression, and keep abreast of new federal guidance.³⁰⁶

³⁰⁴ Email communication with Regan Smith.

³⁰⁵ See *Sioux Falls COVID-19 Response* webpage for links to resources <https://www.siouxfalls.org/covid19>.

³⁰⁶ See *OCR Issues Bulletin on Civil Rights Laws and HIPAA Flexibilities that Apply During the COVID-19 Emergency*. Available at <https://www.hhs.gov/about/news/2020/03/28/ocr-issues-bulletin-on-civil-rights-laws-and-hipaa-flexibilities-that-apply-during-the-covid-19-emergency.html>. Full notice available at <https://www.hhs.gov/sites/default/files/ocr-bulletin-3-28-20.pdf>.

Chapter 9 – Police Procedures

I. Federal Requirements

To treat people with disabilities equitably, police must: (1) institute training on interactions with people with disabilities, (2) enact policies as required to create effective systems and communications for dealing with people with disabilities, and (3) make reasonable modifications in their policies, practices, and procedures that are necessary to ensure accessibility for individuals with disabilities, unless making such modifications would fundamentally alter the program or service.³⁰⁷ Police, as do other aspects of government, have a duty to ensure that their communications and interactions with persons with disabilities are as effective as communications and interactions with others.³⁰⁸

Title II of the ADA applies to most police activities. For example:

- Receiving victim complaints;
- Interrogating prisoners;
- Arresting, booking, and holding suspects;
- Operating telephone (911) emergency centers;
- Enforcing laws;
- And other duties.³⁰⁹

³⁰⁷ 28 C.F.R. 35.130(b)(7).

³⁰⁸ 28 C.F.R. 35.160(a). See also, *Richard Bell, et al. v. Catfish Parlour, Inc., et al.*, Civ. No. A-01-CA-583-JN (U.S. Dist. Ct., W.D. Tex., Austin Div. 2002) (comprehensive settlement, monetary award and procedures for police officers to use interpreters when dealing with people who are deaf on police calls); *Lewis v. Truitt*, 960 F.Supp 175, 176-77 (D. Ind. 1997) (police officers who arrested a deaf man, but refused to acknowledge he could not hear, not entitled to summary judgment on ADA claims alleging failure to and other issues).

³⁰⁹ Commonly Asked Questions about the Americans with Disabilities Act and Law Enforcement, U.S. Dept. of Justice (“DOJ Law Enforcement FAQ”). Available at: http://www.ada.gov/q&a_law.htm.

Chapter 9 - Police Procedures

The focus is on appropriate use of force, dealing appropriately with mental illness,³¹⁰ accommodation of physical and mental disabilities, and the need for interpreting and other effective communications.

When problems arise, police may be held liable under the ADA under two theories of liability: “wrongful arrest”, and/or a failure to provide reasonable accommodation. Improper police responses to people with disabilities when police misperceive the effects of disability as instead being criminal in nature may result in wrongful arrest. In instances of use of force (excessive or otherwise), injury or death has resulted.³¹¹

Congress specifically addressed wrongful arrest discrimination when the House Judiciary Committee stated: “In order to comply with the non-discrimination mandate, it is often necessary to [train] public employees about disability. For example, persons who have epilepsy, and a variety of other disabilities, are frequently inappropriately arrested and jailed because police officers have not received proper training in [how to recognize and aid people having]

³¹⁰ See, e.g., Peter Blanck & Jonathan Martinis, *“The right to make choices”*: National Resource Center for Supported Decision-Making, 3 *Inclusion* 24 (2015); Dilip Jeste, Graham Eglit, Barton Palmer, Jonathan Martinis, Peter Blanck, & Elyn Saks, *An Overview of Supported Decision in Serious Mental Illnesses*, 81 *Psychiatry* 28 (2018).

³¹¹ See., e.g., Theresa Vargas, *Md. man with Down syndrome who died in police custody loved law enforcement*, The Washington Post, Feb. 19, 2013. Available at: http://www.washingtonpost.com/local/md-man-with-down-syndrome-who-died-in-police-custody-loved-law-enforcement/2013/02/19/10e09fe0-7ad5-11e2-82e8-61a46c2cde3d_print.html. violent conclusion, ending with the serious injury or death of the disturbed person.”). See generally Jennifer Fischer, Student Article, *The Americans with Disabilities Act: Correcting Discrimination of Persons with Mental Disabilities in the Arrest, Post-Arrest, and Pretrial Processes*, 23 *LAW & INEQ.* 157, 195 (2005) (“A lack of community-based treatment alternatives and law enforcement’s inability to appropriately respond to persons with a mental illness through appropriate policies and programs result in the unjustified institutionalization of persons with a mental illness in jails and prisons, and too often result in their deaths.”).

Chapter 9 - Police Procedures

seizures. . . . Such discriminatory treatment based on disability can be avoided by proper training.³¹²

The DOJ delineates common problems that people with disabilities may have when interacting with law enforcement personnel.³¹³ These problems may form the basis for liability for wrongful arrest if the law enforcement personnel misperceive an individual's conduct based upon a disability as unlawful or suspicious conduct:

- Unexpected actions taken by some individuals with disabilities may be misconstrued by officers or deputies as suspicious or illegal activity or uncooperative behavior.
- Individuals who are deaf or hearing impaired or who have speech disabilities, have mental illness or intellectual and developmental disabilities, or who are blind or visually impaired may not recognize or be able to respond to police directions. These individuals may erroneously be perceived as uncooperative.
- Some people with disabilities may have a staggering gait or slurred speech as a result of their disabilities or the medications they take. These characteristics, which can be associated with neurological disabilities, mental health or emotional disturbances or conditions, or medical conditions, such as hypoglycemia, may be misperceived as intoxication.³¹⁴

Conditions, such as mental illness, Autism Spectrum Disorder (ASD), or intellectual and developmental disabilities, may lead to particular types of interactions with police. For example, "stereotypes and easily misunderstood behaviors (of ASD) contribute to the likelihood

³¹² H.R. Rep. No. 101-485, pt. III (1990), reprinted in 1990 U.S.C.C.A.N. 445 (quoted at 960 F. Supp. at 178; 1994 WL 589617, at *6 n.12).

³¹³ DOJ Law Enforcement FAQ.

³¹⁴ DOJ Law Enforcement FAQ.

Chapter 9 - Police Procedures

of an encounter with police. People with ASD and other developmental disabilities are ‘seven times more likely to come into contact with law enforcement.’”³¹⁵

Standard police responses, which can include lights and sirens, and loud and unfamiliar voices, may escalate negative behaviors. “[T]he more force a police officer applies to gain control over the situation, the more dangerous and out of control the situation likely becomes.”³¹⁶ This can increase the danger to both the person with the disability as well as to the police officer and others in the vicinity.

“Instead, calmness, patience, and geographical containment, as opposed to physical force, will usually lead to a de-escalation of behavior within a few minutes.”³¹⁷ “Police cannot be diagnosticians or pseudo-mental health professionals - but they can help stabilize a situation, work to keep all involved parties safe (including responding officers), make effective referrals when appropriate, and improve the lives of people with mental illnesses and their loved ones by keeping them out of a system ill equipped to meet their needs.” ³¹⁸

³¹⁵ Elizabeth Hervey Osborn, *What Happened to ‘Paul’s Law’?: Insights on Advocating for Better Training and Better Outcomes in Encounters Between Law Enforcement and Persons with Autism Spectrum Disorders*, 79 Univ. of Col. L. Rev., Issue 1, 333, 341(Winter 2008).

³¹⁶ *Id.*, Osborn, 79 Univ. of Col. L. Rev., Issue 1, at 344.

³¹⁷ *Id.* See also Dennis Debbaudt and Darla Rothman, Ph. D., *Contact with Individuals with Autism, Effective Resolutions*. FBI Law Enforcement Bulletin, Vol. 70, No. 4 (April 2001). Available at:

http://www.autismriskmanagement.com/documents/FBI_Law_Enforcement_Bulletin.pdf. And see Dennis Debbaudt, *Autism & Law Enforcement: 25 Field Response Tips*. Available at: http://www.autismriskmanagement.com/documents/Law_Enforcement.pdf.

³¹⁸ Council of State Governments Justice Center, *Criminal Justice/Mental Health Consensus Project* (Consensus Project Report) at 34. Available at: http://consensusproject.org/downloads/Entire_report.pdf.

Chapter 9 - Police Procedures

When encounters between police and people with mental illness occur (whether they are a victim of a crime; a witness to a crime; the subject of a nuisance call; a possible offender; or a danger to themselves or others), police must recognize whether mental illness may be a factor in the incident, and to what extent, before deciding on an appropriate response.³¹⁹ To assist officers in addressing such contacts, departments should develop protocols and training beforehand.³²⁰

Successful approaches to consider include models such as Crisis Intervention Teams (CITs) (using specially trained uniformed officers to act as primary or secondary responders to every call in which mental illness is a factor), Comprehensive Advanced Response (where all officers receive advanced training), hiring mental health professionals to co-respond, using Mobile Crisis Team (MCT) co-responders (where mental health professionals employed by other agencies respond), or development and deployment of Psychiatric Advanced Directives or “PADs” and Supported Decision-Making or “SDM” strategies.³²¹ These activities help to coordinate actors with appropriate training in different disciplines to allow safer and more informed outcomes for all. As part of the 2021 COVID-19 relief bill, the American Rescue Plan, Pub.L. 117-2, Section 9813, new federal funding is available to states to support an expansion of mental mobile crisis teams. The federal contribution can be 85% of the cost for the first three

³¹⁹ *Id.* at 40.

³²⁰ *Id.*

³²¹ *Id.* at 41. See Peter Blanck & Jonathan Martinis, “The right to make choices”: National Resource Center for Supported Decision-Making, 3 *Inclusion* 24 (2015); Dilip Jeste, Graham Eglit, Barton Palmer, Jonathan Martinis, Peter Blanck, & Elyn Saks, *An Overview of Supported Decision in Serious Mental Illnesses*, 81 *Psychiatry* 28 (2018) (for example, use of Psychiatric Advanced Directives or “PADs” and Supported Decision-Making or “SDM”).

Chapter 9 - Police Procedures

years. The State must file an amendment to its Medicaid plan or seek or amend a waiver to secure the additional funding.³²²

Police have a duty to provide reasonable accommodation during arrest and at other times. The Eighth Circuit has held that Title II can apply to arrests.³²³ In *Gorman v. Bartch*, the Eighth Circuit recognized that the general regulatory obligation to modify policies, practices, or procedures under the ADA requires law enforcement to make changes in policies that result in discriminatory arrests or abuse of individuals with disabilities.

In *Gorman*, the court held that police must be prepared to transport a prisoner who uses a wheelchair in an accessible vehicle unless doing so would create an undue burden.³²⁴

The DOJ suggests³²⁵ other modifications to policies to accommodate disabilities may include:

- Taking complaints at an alternative location when a police station is inaccessible (and training officers of the change in practice);
- Allowing prisoners with diabetes to take food in their cells;

³²²*An Alternative to the Police: New Funding is Available for Mental Health Mobile Crisis Teams*, Bazelon Center for Mental Health Law. Available at <https://secureservercdn.net/198.71.233.254/d25.2ac.myftpupload.com/wp-content/uploads/2021/04/ARP-mobile-crisis-provisions-final.pdf>.

³²³ See *Gorman v. Bartch*, 152 F.3d 907, 912-13 (8th Cir. 1998) (reversing dismissal of ADA suit alleging police had discriminated against arrestee with paraplegia by transporting him to police station in vehicle unequipped to safely accommodate people using wheelchairs).

³²⁴ *Id.* See also, DOJ Law Enforcement FAQ. The Supreme Court heard a case that may affect these current duties. See *City and County of San Francisco v. Sheehan*, 743 F.3d 1211 (9th Cir. 2014), cert. granted, Civ. No. 13-1412, Nov. 25, 2014. In the end, the Supreme Court dismissed the case as improvidently granted without definitively answering the question as to whether the police need to consider an individual's disability under the ADA in choosing their actions. *City and County of San Francisco v. Sheehan*, 135 S. Ct. 1765 (2015) (Police officers who forcibly entered the room of a woman with a mental disability and shot her are entitled to qualified immunity from a lawsuit seeking redress for the woman's injuries, because there was no clearly established law requiring them to accommodate her mental illness).

³²⁵ DOJ Law Enforcement FAQ.

Chapter 9 - Police Procedures

- Allowing individuals who use wheelchairs to travel in the street where sidewalks are inaccessible;
- Handcuffing deaf prisoners with their hands in front to allow communication;
- Modifying Miranda procedures to ensure an individual with intellectual and developmental disabilities is able to understand her rights;
- Allowing a prisoner to access his medications where such medications do not have abuse potential.

As noted above, police have a duty to ensure that their communications with persons with disabilities are as effective as communications with others.³²⁶ Not all situations will call for sign language: “Whether a qualified sign language interpreter or other communication aid is required will depend on the nature of the communication and the needs of the requesting individual.”³²⁷ What is needed will vary depending on the person with a disability’s needs, and the type of interaction.

Other “auxiliary aids and services” may be appropriate, such as exchange of notes, TDD, and relay calls.³²⁸ The ADA requires that the expressed choice of the individual with the disability, who is in the best position to know her or his needs, should be given primary consideration in determining which communication aid to provide.³²⁹

³²⁶ 28 C.F.R. 35.160(a). See also, *Richard Bell, et al. v. Catfish Parlour, Inc., et al.*, Civ. No. A-01-CA-583-JN (U.S. Dist. Ct., W.D. Tex., Austin Div. 2002) (comprehensive settlement, monetary award and procedures for police officers to use interpreters when dealing with people who are deaf on police calls); *Lewis v. Truitt*, 960 F.Supp 175, 176-77 (D. Ind. 1997) (police officers who arrested a deaf man, but refused to acknowledge he could not hear, not entitled to summary judgment on ADA claims alleging failure to and other issues).

³²⁷ DOJ Law Enforcement FAQ.

³²⁸ *Id.*

³²⁹ *Id.*

Chapter 9 - Police Procedures

For people who use sign language, the nature of the interaction affects whether translators are required, or less formal means such as exchange of notes will suffice. “During interrogations and arrests, [and where Miranda warnings are provided] a sign language interpreter will often be necessary to effectively communicate with an individual who uses sign language.”³³⁰

According to federal model policies, departments should maintain a list of sign language and oral interpretive services available on-call, 24 hours a day.³³¹ The DOJ has continued to be involved in suits where people with disabilities have alleged police departments have failed to enact policies and procedures which ensure effective communication.³³²

II. Sioux Falls Compliance

Sioux Falls Police Department (SFPD) works to comply with the ADA in a number of areas. SFPD has adopted written policies which address several areas related to disability.³³³ Importantly, all 264 police officers receive training on disability issues as part of their standard training and additional departmental training addressing these policies.³³⁴ The SFPD operates from one police station, which is ADA-compliant.

A. Mental Health

³³⁰ *Id.*

³³¹ Model Policy for Law Enforcement on Communicating with People who are Deaf or Hard of Hearing. Available at: <http://www.ada.gov/lawenfmodpolicy.pdf>.

³³² See DOJ Press Release Settlement Agreements with City of Englewood, CO, Mar. 8, 2013, and Arapaho County Sheriff's Office, and Mar. 21, 2013. Available at: <http://www.justice.gov/opa/pr/2013/March/13-crt-332.html>.

³³³ See Appendix 16, SFPD Policies Related to Disability.

³³⁴ Meeting with SFPD personnel, Mar. 14, 2012. For example, certain officers who have received advanced training off-site have propagated that to others in the department.

Chapter 9 - Police Procedures

The SFPD has adopted a policy on Mental Health Investigations (Policy #: 721)³³⁵ to coordinate responses and assist officers where severe mental illness may be at issue. The policy implements South Dakota law allowing police to apprehend a person who is in mental health crisis such that the officer has probable cause to believe the person is “severely mentally ill and in such condition that immediate intervention is necessary for the protection from physical harm to self or others.”³³⁶ The SFPD also instructs officers on “Excited Delirium”.³³⁷

Apart from this general provision, SFPD has sought to improve its responses to mental health crises by creating Crisis Intervention Teams (CIT). The Department, in conjunction with health care providers and others, lobbied the state legislature to enable this approach. To date, some 104 officers have undergone advanced crisis intervention training which consists of a 40 hour training course that focuses on recognizing individuals in a mental illness crisis and responding accordingly using de-escalation skills and community relations in an attempt to build a relationship with the individual, and provide appropriate referral or placement and jail diversion.³³⁸ Nationwide, CIT Officers have an approximate 80% decrease in officer injury as well as a decrease in citizen injury. Officers then coordinate responses amongst the participating professionals.³³⁹ Some officers have received additional training in related aspects

³³⁵ *SFPD Policy 721, Mental Health Investigations – Suicide Attempts*. Available at <https://www.siouxfalls.org/police/policy-manual/manual/0700>.

³³⁶ Apprehension by peace officer of person believed to require emergency intervention--Transportation to appropriate regional facility, S.D.C.L. § 27A-10-3. Available at: https://sdlegislature.gov/Statutes/Codified_Laws/2051118.

³³⁷ *SFPD Policy 713, Excited Delirium*. Available at <https://www.siouxfalls.org/police/policy-manual/manual/0700>.

³³⁸ December 7, 2020 email from Sergeant Tarah Walton.

³³⁹ See Appendix 17, Documents Related to Crisis Intervention Teams.

Chapter 9 - Police Procedures

such as suicide intervention, mental health first aid, and mental health training for school resource officers.³⁴⁰

The City has worked with community health providers to establish Mobile Crisis Teams (MCT). The MCT is composed of mental health providers who are available 24/7 to respond in person (or via Facetime as of this year), to those who meet criteria for a mental hold in hopes of either diverting the hold or working with the individual for a voluntary admission to a mental health facility. MCT is deployed by law enforcement only.³⁴¹ MCT has a hold diversion rate of approximately 92% (meaning 92% of citizens that typically would have been taken into custody and placed involuntarily in a mental hospital, were not and were left in the community or accepted a voluntary admission to a mental health facility).³⁴² Officers responding to “Mental Health “ calls are instructed to consider contacting the MCT.

The City should consider whether there are opportunities to expand the MCT system available under the 2021 COVID-19 relief bill, the American Rescue Plan, Pub.L. 117-2, Section 9813. New federal funding is available to states to support an expansion of mental mobile crisis teams. The federal contribution can be 85% of the cost for the first three years. The City could

³⁴⁰ May 22, 2020 email from Jason Leach to Daniel Haggar.

³⁴¹ December 7, 2020 email from Sergeant Tarah Walton.

³⁴² December 7, 2020 email from Sergeant Tarah Walton. In 2018, SFPD Officers responded to 2,656 known mental illness and suicide related calls for service. CIT Officers were present on 1,202 of those calls. The MCT responded to 464 of these calls and of those calls, the diversion rate was 92.28%. In 2019, SFPD Officers responded to 2,948 known mental illness and suicide related calls for service. CIT Officers were present on 1,224 of those calls. The MCT responded to 408 of these calls and of those calls, the diversion rate was 92.36%.

Chapter 9 - Police Procedures

work with the State to file an amendment to its Medicaid plan or seek or amend a waiver to secure the additional funding.³⁴³

We earlier considered certain periods of CIT responses. Between August, 2011 and January, 2013, CIT & MCT responded to approximately 451 “mental health” calls. In the vast majority of these, no custodial interventions were required, but police were able to address situations. Where further treatment was indicated, 39 individuals agreed to voluntary hospitalization, while 31 were engaged in mental health holds. Recently, SFPD has received an increased rate of “mental health” calls.

In 2020, the SFPD added a Mental Health Community Resource Officer position. She is intended to become the department subject matter expert on mental health and addiction/substance abuse within the law enforcement role, and to work with individuals, families, community groups, and providers. She works with the Sioux Falls Mental Health Court, a specialized court established by the state that is intended to “enhance public safety and improve the quality of life for participants, their families and communities statewide by holding participants accountable through a judicially monitored regimen of treatment and supervision to promote long-term recovery.”³⁴⁴

The City is establishing a Community Triage Center known as the Link in partnership between the City, Minnehaha County, Avera Health, and Sanford Health that will offer

³⁴³ *An Alternative to the Police: New Funding is Available for Mental Health Mobile Crisis Teams*, Bazelon Center for Mental Health Law. Available at <https://secureservercdn.net/198.71.233.254/d25.2ac.myftpupload.com/wp-content/uploads/2021/04/ARP-mobile-crisis-provisions-final.pdf>.

³⁴⁴ *Mental Health Court Participant Handbook* at p. 3.. Available at <https://ujs.sd.gov/uploads/drugcourt/MinnehahaCountyMentalHealthCourtHandbook.pdf>.

Chapter 9 - Police Procedures

assistance and serve as a first point of contact for individuals seeking mental health care or addiction counseling. It is expected to open 2021.³⁴⁵

B. Modifications to Policies

SFPD policies provide that officers may use discretion when transporting prisoners with disabilities.³⁴⁶ Officers can depart from standard handcuffing procedures. Officers are instructed to transport wheelchairs, crutches, prosthetics, and medications with, but not in the possession of the prisoner.³⁴⁷ The policy states that prisoners with physical disabilities may be transferred in agency vehicles, but require that the officer shall take all reasonable precautions to ensure the security and reasonable comfort of the prisoner. Separately, the policy notes that “(s)tandard transport procedures may be dangerous for many people with mobility disabilities.”³⁴⁸ In our discussions with SFPD, they indicate that transport for people who use wheelchairs has been done through third-party accessible vans.

C. Communications

SFPD policies provide guidance for officers when dealing with someone who is deaf or hard of hearing. The policy contains mandatory requirements that officers determine the person’s preferred means of communication, limitations on reliance on family or friends for interpretation, indications where sign or other types of interpretation is especially important, and guidance on avoiding handcuffs.³⁴⁹ Officers are provided with cards to assist them in

³⁴⁵ See <https://www.siouxfalls.org/news/2020/08/26/gift>. And see <https://www.minnehahacounty.org/ctcp/reports/Community%20Triage%20Center%20Conceptual%20Plan.pdf>.

³⁴⁶ Sioux Falls Police Department, Policy: Transport of Prisoners.

³⁴⁷ *Id.*

³⁴⁸ Appendix 16, SFPD Policies Related to Disability, Policy 1532.

³⁴⁹ Appendix 16, SFPD Policies Related to Disability, Policy 1531.

coordinating sign language interpreters. The police station has equipment for Video Relay Interpretation.

III. Recommendations

The SFPD should continue to ensure that officers are aware of the obligation to modify policies and procedures at times. Review of Policy 1007 regarding transport indicates that the SFPD should continue to ensure through policy and training that officers understand the potential for danger in the transport of a prisoner who uses a wheelchair in a standard agency vehicle.³⁵⁰ The policies provide discretion when securing prisoners, but the Department should consider the appropriate mechanisms to ensure that varied other modifications as indicated in the DOJ Law Enforcement FAQ are communicated to staff through training, if this not already occurring.

In our discussion with police personnel, it was not apparent whether the department analyzes in a systemic way its responses to people with disabilities, particularly responses to people in mental health crisis. To the extent it is not doing so already, we recommend that appropriate personnel develop a system to analyze and learn from such responses.

We are, as is the SFPD, particularly concerned by potential for injury or death in restraint of people in mental health crisis. The department instructs officers on “Excited Delirium.”³⁵¹ We understand the difficulties officers encounter on the street in responding to

³⁵⁰ See *Gorman v. Barch*, 152 F.3d 907, 912 13 (8th Cir. 1998) (reversing dismissal of ADA suit alleging police had discriminated against arrestee with paraplegia by transporting him to police station in vehicle unequipped to safely accommodate people using wheelchairs).

³⁵¹ See Méabh O'Hare, Joshua Budhu and Altaf Saadi, *Police keep using 'excited delirium' to justify brutality. It's junk science. The "diagnosis" misappropriates medical terminology to shield officers from accountability.*

Chapter 9 - Police Procedures

potentially dangerous situations. However, instructing officers about dangers of “excited delirium” and individuals with “exceptional strength” and “high levels of pain tolerance” may lead officers in some instances to respond excessively. The City and SFPD have done a good job in creating policies and plans in this area. They should continue to update plans, policies, and training to continue this positive momentum.

(Discussing deaths of individuals in police custody, particularly when in physical restraint, and subsequent justification as due to “excited delirium.”) The Washington Post. July 17, 2020. Available at https://www.washingtonpost.com/outlook/chokehold-police-excited-delirium/2020/07/17/fe907ec8-c6bc-11ea-b037-f9711f89ee46_story.html.

Chapter 10 – Other City Buildings and Programs

I. Sioux Falls Arena (old arena)

This is a multi-function facility housing a variety of events, including professional and amateur sporting events, circuses, concerts, conventions, and assorted major entertainment shows. Programs of the Sioux Falls Arena have been evaluated for program accessibility to persons with disabilities of all types.

In response to complaints in the mid- to late-1990s, modifications to the facilities and policies were made in a cooperative fashion and in settlement of a formal complaint. Groups of citizens with disabilities, and groups representing them worked to expand access in physical seating in the Arena, create a policy manual, create appropriate signage, redesign the Arena box office, and train staff and notify vendors of policies related to people with disabilities. This mediated agreement formed the basis of other policies at various City venues.

As with other ticketing venues, the Arena will need to adjust its procedures in accord with the new ticketing procedures and companion seating requirements in the 2010 regulations to allow for three companions.³⁵² The policy does not describe the number of companion tickets which can be obtained.³⁵³

II. Denny Sanford Premier Center and Convention Center

³⁵² See 2010 DOJ ADA Regulations, 75 Fed. Reg. at 56179-180.

³⁵³ <https://www.dennysanfordpremiercenter.com/p/about/policies--procedures1/ada-policy>.

Chapter 10 - Other City Buildings and Programs

As a result of a bond offering voted on by the citizens, the City constructed a new arena attached to the Convention Center. This facility was constructed to be ADA compliant. The ADA Accessibility Review Board and others representing people with disabilities were involved in the design process and had an opportunity to inform the plans. Initial seating designs were somewhat lacking in vertical and horizontal seating integration/dispersion. This observation by the board and others resulted in changes and improvements. In a cursory review of the Convention Center and Arena, no issues were noted except the placement of large planter in the entry halls to the accessible bathroom (where the planters blocked access). This has been addressed.

Assistive Listening Devices are available on request. The Denny Sanford Center shows an accessibility policy on its website.³⁵⁴ The policy does not describe the number of companion tickets which can be obtained.³⁵⁵

The City should consider captioning on the scoreboards, or at the least, provide information via other avenues (whether video monitors or other technologies). The DOJ originally had proposed to address requirements for captioning at sporting venues in the 2008 rulemaking, but it declined to do so in the final revised 2010 regulations, stating that the issue

³⁵⁴ *Id.*

³⁵⁵ *Id.*

Chapter 10 - Other City Buildings and Programs

requires further consideration and review.³⁵⁶ The DOJ noted, however, that “the 1991 Title II and Title III regulations and statutory requirements (to provide effective communication and to make available auxiliary aids and services) are not in any way affected by” this decision.³⁵⁷

In the first decision of its kind, the U.S. Court of Appeals for the Fourth Circuit held that Title III of the ADA requires a football stadium to provide auxiliary access to the aural content broadcast over the stadium’s public address system.³⁵⁸ DOJ has required this in settlements and has included captioning in some settlements.³⁵⁹

III. Washington Pavilion

This facility was completed in 1999 and was designed and constructed to be fully compliant with ADA Accessibility Guidelines. The Pavilion houses public gathering spaces, specialty areas, concerts and other performances, a science center geared towards children, and administrative offices. Extensive attention was given to full accessibility in the construction of this facility.

Prior to the official opening of the facility for public programs, the Mayor's Committee for Citizens with Disabilities oversaw the process and conducted a full walk-through of the

³⁵⁶ Specifically, in its Notice of Proposed Rulemaking issued June 17, 2008, the DOJ proposed that stadiums with seating capacity of 25,000 or more be required to provide captioning on scoreboards and video monitors for safety and emergency information. 73 Fed. Reg. 34,466, 34,555 (June 17, 2008).

³⁵⁷ 28 C.F.R. pt. 35, app. A at 644 (2011); 28 C.F.R. pt. 36, app. A at 764 (2011).

³⁵⁸ See *Feldman v. Pro Football, Inc.*, 419 Fed. Appx. 381, 2011 U.S. App. LEXIS 6188 (4th Cir. Mar. 25, 2011).

³⁵⁹ See Press Release, U.S. Attorney’s Office, Cleveland Cavs and Quicken Loans Arena Reach Agreement to Improve Access for Patrons with Disabilities (Dec. 13, 2012). Available at <https://www.justice.gov/archive/usao/ohn/news/2012/13deccavs.html>.

facility to assess accessibility and provide further recommendations. An ADA policy was developed.

The main performance space features augmented audio.³⁶⁰ The facility has considered captioning equipment but has not settled on a particular alternative.³⁶¹

IV. Sioux Falls Stadium

This stadium is the home of the Sioux Falls Canaries, a local professional baseball team, which leases and manages the facility. The facility also plays host to various amateur baseball events during the summer months. This baseball facility was redesigned and constructed to be accessible for persons with disabilities, including integrated accessible seating distributed throughout the stadium. The website notes “special needs” seating on the ticketing page, but there is no written policy otherwise. Staff indicate that employees receive annual training including training on the location of accessible facilities and seating.

1) Recommendation

The City should assist in or otherwise require the development of a policy that can be advertised on the website so potential customers know of the availability of accessible and companion seating, and to confirm that ticketing policies for companions and other issues designated in the 2010 regulations are followed.

³⁶⁰ Interview with Larry Toll (President), Washington Pavilion, Aug, 29, 2012.

³⁶¹ *Id.*

I. Federal Requirements

As with other governmental services, library services must be accessible. Federal guidelines provide architectural requirements for physical accessibility in new or reconstructed libraries under the ADAAG. These requirements, in addition to the generally applicable architectural requirements of the ADAAG, address seating areas, book and magazine stacks and racks, card catalogs, and security gates.

8.1. General. In addition to the requirements of section 4, the design of all public areas of a library shall comply with 8, including reading and study areas, stacks, reference rooms, reserve areas, and special facilities or collections.

8.2. Reading and Study Areas. At least 5 percent or a minimum of one of each element of fixed seating, tables, or study carrels shall comply with 4.2 and 4.32. Clearances between fixed accessible tables and between study carrels shall comply with 4.3.

8.3. Check-Out Areas. At least one lane at each check-out area shall comply with 7.2(1). Any traffic control or book security gates or turnstiles shall comply with 4.13.

8.4. Card Catalogs and Magazine Displays. Minimum clear aisle space at card catalogs and magazine displays shall comply with Fig. 55. Maximum reach height shall comply with 4.2, with a height of 48 in (1220 mm) preferred irrespective of approach allowed.

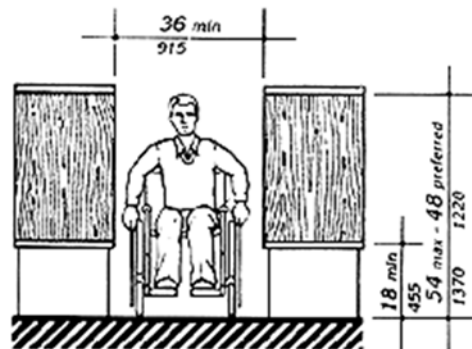

Fig. 55
Card Catalog

8.5. Stacks. Minimum clear aisle width between stacks shall comply with 4.3, with a minimum clear aisle width of 42 in (1065 mm) preferred where possible. Shelf height in stack areas is unrestricted (see Fig. 56).³⁶²

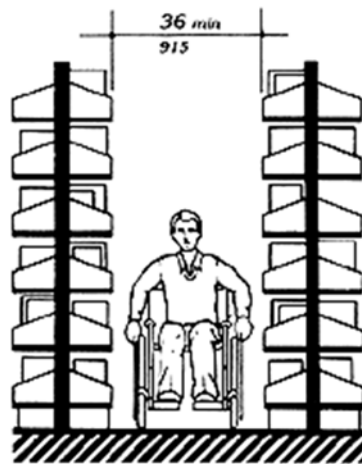

Fig. 56
Stacks

Emerging use of information technology (IT) has changed delivery of content from merely physical books and magazines to electronic information. Amongst the benefits of

³⁶² ADA Accessibility Guidelines for Buildings and Facilities, Section 8. Available at: <https://www.access-board.gov/adaag-1991-2002.html#lib>.

information being distributed through IT, it is available 24/7, and may be used in ways that make information more readily usable by people with print disabilities.

The DOJ and Department of Education issued a “Dear Colleague” letter to colleges and universities in 2010 observing that “[t]echnological innovations have opened a virtual world of commerce, information, and education to many individuals with disabilities for whom access to the physical world remains challenging.”³⁶³ While IT can increase availability of information and services to people with disabilities, unfortunately the manner of presentation too frequently creates or maintains barriers resulting in unequal access.³⁶⁴

The National Federation of the Blind has filed complaints concerning IT against a number of local public libraries based on prior settlements between the Department of Education / DOJ actions against public universities over e-readers.³⁶⁵ These complaints allege that technology used by the libraries, notably certain e-readers available for lending, are inaccessible to the blind and others with print-disabilities.

The DOJ and NFB have achieved a number of settlement agreements requiring libraries “acquire only technology that does not exclude persons who are blind or others” who need accessibility features such as text-to-speech or Braille output and the ability to access the

³⁶³ Joint “Dear Colleague” Letter: Electronic Book Readers, U.S. Department of Justice, Civil Rights Division, U.S. Department of Education, Office for Civil Rights, June 29, 2010. Available at: <http://www2.ed.gov/about/offices/list/ocr/letters/colleague-20100629.html>.

³⁶⁴ DOJ Proposed Web Regulation. Available at: http://www.ada.gov/anprm2010/web%20anprm_2010.htm.

³⁶⁵ See, e.g., DOJ Settlement Agreement re NFB and American Council of the Blind (ACB) concerning Arizona State University Kindle program, dated January 8, 2010. Available at: http://www.ada.gov/arizona_state_university.htm.

device's menus and controls independently."³⁶⁶ While these actions have concerned e-readers, they are a precedent to action regarding similar web-based library lending programs.

Without specifying online reader programs, the DOJ has included requirements in Project Civic Access settlement agreements addressing the web access requirements seen in other types of such settlements.³⁶⁷ There is no limitation in the DOJ website guidance relied upon in these settlement agreements that would carve out or otherwise exempt online book and magazine distribution.

One settlement agreement between the DOJ and Louisiana Tech University is instructive as to the direction of future terms DOJ may require.³⁶⁸ The DOJ alleged that the university violated the ADA by using a version of an online learning product that was inaccessible to a blind student. The settlement agreement provides more specificity regarding the technical requirements needed to maintain accessibility and requires all new and recent content be accessible in accordance with the Web Content Accessibility Guidelines (WCAG) 2.0 Level AA standard. It further requires that:

The University will ensure that any new technology it makes available to students, prospective students or applicants, including web applications, hardware, software, telecommunications, and multimedia is accessible, if such

³⁶⁶ See, e.g., press releases re settlements in action against Sacramento Public Library. Aug. 29 & 30, 2012. Available at: <http://www.justice.gov/opa/pr/2012/August/12-crt-1059.html> and <https://nfb.org/about-us/press-room/national-federation-blind-settles-complaint-against-sacramento-public-library>. Settlement Agreement, Aug. 28, 2012. Available at: http://www.ada.gov/sacramento_ca_settle.htm. Other such actions have included the Free Library of Philadelphia.

³⁶⁷ See, e.g., DOJ Settlement Agreement with City of Des Moines, IA, and City of Des Moines, IA Public Library, dated March 2, 2011. Available at: http://www.ada.gov/des_moines_pca/des-moines_pca_sa.htm. DOJ Settlement Agreement with Daviess County, Kentucky, dated Jan. 3, 2006. Available at: <http://www.ada.gov/DaviessCountyLibKYpca.htm>.

³⁶⁸ DOJ Settlement Agreement with Louisiana Tech University, dated July 23, 2013 DOJ Louisiana Tech Settlement. Available at: <http://www.ada.gov/louisiana-tech.htm>.

new technology is commercially available and its purchase does not result in undue financial and administrative burdens or a fundamental alteration. If a product is available and meets some, but not all, of the relevant accessibility provisions of WCAG 2.0 AA, the product that best meets the standard must be procured.³⁶⁹

The requirement that the university *only* purchase accessible technology products (that are to be used by the public), if available, is broad, and continues to expand on the terms seen in prior settlements.³⁷⁰

Other access issues have not been a subject of litigation or DOJ compliance, but should be considered.

II. Sioux Falls Compliance

The Siouxland Libraries currently maintains five branch libraries in the City and is affiliated with other libraries in the surrounding area through a merger of the Sioux Falls Public Library and the Minnehaha County Rural Public Library in 1995. Siouxland Libraries provides services to the citizens of Sioux Falls and Minnehaha County.³⁷¹ Each of the five City branches is physically accessible and has been newly constructed or renovated to comply with the ADA, including the ADAAG requirements specific to libraries.

One area of concern to library staff has been managing situations where patrons, whether due to alcohol or drug impairment, or mental health issues, create disruption in the libraries resulting from the conditions. The library has a policy of “expected behavior” as part of

³⁶⁹ DOJ Louisiana Tech Settlement, Exh. 1. Available at: <http://www.ada.gov/louisiana-tech.htm#ex1>.

³⁷⁰ For a review, see Peter Blanck, *e-Quality: The Struggle for Web Accessibility by Persons with Cognitive Disabilities* (2014, Cambridge University Press).

³⁷¹ See <http://www.siouxlandlib.org/about-us.aspx>. The authors have only addressed libraries in the City proper.

Chapter 11 - Libraries

the general rules. There is a separate policy that is posted both in the libraries and on the webpage. Staff use the rule as a starting point to address issues as they describe with “respect and compassion.”³⁷² This comports well with recommendations from the American Library Association.³⁷³ Staff have received training on issues related to disability by the ADA Coordinator.

For public events, the Library has brought in sign language translators upon request. Each branch, in addition to books and seating areas, maintains several computers for the public. Each branch has at least one computer with accessible technology (such as JAWS). These public computers may be reserved online or in the library, and the accessible computers can be booked, specifically.

The Library maintains a website which provides access to various features, such as a catalog, a calendar of events, list of locations, and access to downloadable materials. The Library website is currently being revamped and now resides on its own node away from the City of Sioux Falls site. The City uses a service called SiteImprove, which, among other things, tracks accessibility scores on the website and recommends fixes.

The library provides online information systems where users can view material online or download e-books, e-audio, and e-magazines at any time. These third-party programs to which the library subscribes host materials, including CloudLibrary (which has e-books and audio

³⁷² Meeting with Mary John, Director, Sioux Falls Public Library, and staff, Jan 14, 2013.

³⁷³ See *People with Mental Health Issues: What You Need to Know, Library Accessibility Tip Sheet 7*, Association of Specialized and Cooperative Library Agencies, a division of the American Library Association. Available at: http://www.ala.org/asgcla/sites/ala.org.asgcla/files/content/asclaprotocols/accessibilitytipsheets/tipsheets/7-Mental_Illness.pdf.

books), RBDigital (which has e-audio, e-magazines and comics), and Hoopla (which has e-books, movies and music). Other offerings include third-party vendors that are subscribed to by the South Dakota State Library and made available to all libraries in the state. They include BookFlix and Miss Humblebee’s Academy which both offer children’s books.

Information from CloudLibrary:

The cloudLibrary team worked early on with the National Federation of the Blind of Minnesota to ensure that the cloud library system is access to as many patrons as possible. With continued updates to our system and apps along with the updates and changes that occur with programs like JAWS our team does work to ensure compatibility to the best of our ability.

Our iOS app is designed to be compatible with iOS Voiceover mode. Voiceover allows users with vision impairment to browse, borrowed and then listen to books. We created this solution with input from the National Federation of the Blind who recommended that iOS Voiceover mode was the gold standard for users with vision impairment. As we continue to develop our apps, we will continue to ensure our users can access cloudLibrary content through this feature.

III. Recommendations

- 1) We note that one computer at each branch features full accessibility features. Staff should investigate adding one or more such computers to ensure equivalent wait-times for people with and without disabilities. Staff continue to monitor use to ensure there remain limited wait times for accessible machines. For example, some branches may be closer to service providers or residences and have a greater demand for accessible machines.

Chapter 11 - Libraries

- 2) Staff should continue to investigate evolving accessible options for the online systems. Staff should be prepared to help instruct library users on how to bootstrap access via e-readers and tablets. However, for users with only computers, more substantial “reasonable modifications” may be required, such as an e-reader/tablet borrowing program for people with disabilities.³⁷⁴

³⁷⁴ See *Frequently Asked Questions About the June 29, 2010, Dear Colleague Letter*, US Department of Education, Office for Civil Rights, (¶¶ 11, 14) , dated May 26, 2011. Available at: <http://www2.ed.gov/print/about/offices/list/ocr/docs/dcl-ebook-faq-201105.html>.

I. Federal Requirements

As with other governmental services, health care services must be accessible:

Accessibility of doctors' offices, clinics, and other health care providers is essential in providing medical care to people with disabilities. Due to barriers, individuals with disabilities are less likely to get routine preventative medical care than people without disabilities. Accessibility is not only legally required, it is important medically so that minor problems can be detected and treated before turning into major and possibly life-threatening problems.³⁷⁵

In the extreme, discrimination based on disability may result in loss of access to federal funding. In the case of a doctor who failed to operate on the back of a patient with HIV, the Department of Health and Human Services (HHS) terminated access to Medicaid funding.³⁷⁶ HHS regulates non-discrimination mandates in health care under the ADA and Section 504 of the Rehabilitation Act of 1973.³⁷⁷ HHS regulates similar non-discrimination provisions found in the Affordable Care Act,³⁷⁸ and various other health care funding streams in community block grants and the Public Health Services Act.³⁷⁹

³⁷⁵ *Access To Medical Care For Individuals With Mobility Disabilities*, U.S. Department of Justice, Civil Rights Division, U.S. Department of Health and Human Services Office for Civil Rights (DOJ/HHS Access to Medical Care guide). Available at: http://www.ada.gov/medicare_ta.htm.

³⁷⁶ See News Release, *Surgeon who discriminated against HIV positive patient loses federal funding*, Dept. of Health and Human Services Press Office. July 18, 2013. Available via archive at: <https://wayback.archive-it.org/3926/20170120082608/https://www.hhs.gov/about/news/2013/07/18/surgeon-who-discriminated-against-hiv-positive-patient-loses-federal-funding.html>.

³⁷⁷ HHS regulations of Section 504 can be found in 45 C. F. R. 84. These regulations substantially mirror the DOJ regulations discussed elsewhere in this report and prohibit discrimination, require program accessibility, self-evaluation, and effective communications.

³⁷⁸ See Section 1557 of the Patient Protection and Affordable Care Act, Pub. L. 111-148, 124 Stat. 119 (2010) (codified as amended at 42 U.S.C. § 18001, 18116 (Supp. 2010)).

³⁷⁹ See generally <http://www.hhs.gov/ocr/civilrights/resources/laws/index.html>.

Access issues in health care include physical accessibility of facilities and equipment, effective communications, equal treatment despite health condition, particularly HIV status. DOJ enforcement focuses on these issues with the Barrier-Free Health Care Initiative where U.S. Attorneys' offices across the nation and the Department's Civil Rights Division target civil rights actions.³⁸⁰

Other issues in health care that affect disability have not been targeted for enforcement, and do not have particular standards. These include modifications to policies and practices to accommodate patients who are blind or visually impaired (apart from required ADAAG elements in physical construction), practices to support communications and decision making in people with cognitive disabilities, and other programmatic areas.³⁸¹

HHS requires providers seeking Medicare funding to certify compliance and receive clearance with the federal non-discrimination statutes.³⁸² HHS also regulates privacy issues under the Health Insurance Portability and Accountability Act of 1996 (HIPAA).³⁸³ The HIPAA privacy rule regulates disclosure of protected health information by covered entities.³⁸⁴ Among the exceptions and permitted uses, HIPAA regulations allow sharing of protected health

³⁸⁰ See *Barrier-Free Health Care Initiative*, U.S. Dept. of Justice, Civil Rights Division. Available at: <http://www.ada.gov/usao-agreements.htm>. The page lists various actions and settlement agreements with providers.

³⁸¹ In this report, we do not address issues related to access to health care, such as financial and insurance issues. The ADA does not create rights to insurance. Medicaid and Medicare provide health care coverage for people with disabilities, but those funding streams are beyond the scope of this report.

³⁸² See HHS *Civil Rights Clearance for Medicare Provider Applicants*. Available at: <http://www.hhs.gov/ocr/civilrights/clearance/index.html>.

³⁸³ The Health Insurance Portability and Accountability Act of 1996, Pub. L. 104–191, 110 Stat. 1936, 29 U.S.C. § 1181. (HIPAA).

³⁸⁴ See <https://www.hhs.gov/hipaa/for-individuals/guidance-materials-for-consumers/index.html>.

information between a covered health care provider and a patient through a Telecommunications Relay Services (TRS) under the Privacy Rule, and a business associate contract is not required in these circumstances.³⁸⁵

Under proposed regulations from the Centers for Medicare & Medicaid Services (CMS), Federally Qualified Health Centers (FQHC) would be required to develop plans for staff and patients in an emergency.³⁸⁶ These plans would need to be a “comprehensive emergency plan that addresses ‘all-hazards’ policies and procedures, a communication plan, and training and testing by drawing upon a variety of resources that can provide technical assistance.”³⁸⁷

A. Physical Accessibility

Physical accessibility in the health care context breaks down into two areas: (1) accessibility of the building, parking, exam rooms, reception, bathrooms and other public areas, and (2) accessibility of medical equipment. Barriers to access are one factor that has led to disparate health care delivery to people with disabilities. Medicare beneficiaries with functional limitations were shown to receive less preventive care measures, such as pap smears, blood

³⁸⁵ See 45 C.F.R. 164.510(b). See also HHS HIPAA FAQ <https://www.hhs.gov/hipaa/for-professionals/faq/500/is-a-relay-service-a-business-associate-of-a-doctor/index.html>.

³⁸⁶ See *Medicare and Medicaid Programs; Emergency Preparedness Requirements for Medicare and Medicaid Participating Providers and Suppliers*, Department of Health and Human Services, Centers for Medicare & Medicaid Services, 78 F.R. 79082 (Dec. 27, 2013). Available at: <https://www.federalregister.gov/articles/2013/12/27/2013-30724/medicare-and-medicaid-programs-emergency-preparedness-requirements-for-medicare-and-medicaid#h-47>.

³⁸⁷ 78 F.R. 79115.

tests for prostate cancer, and digital rectal prostate exams. These preventive care measures also declined as the number of functional limitations increased.³⁸⁸

1) Exam Rooms:

Accessibility of the medical buildings is governed by the requirements of the ADAAG.

We do not detail these here, but attention should be paid in particular to exam room size. Exam rooms need to be large enough to provide maneuvering room for people using wheelchairs or other mobility aids to access exam equipment.³⁸⁹ Clear floor space needs to be 30 inches wide by 48 inches long, at a minimum. Because some people only transfer from one side or the other, clear floor space must be available on both sides of an exam table or equipment. In the alternative, an office may provide a reverse furniture layout in another exam room.

The room should have enough turning space for an individual using a wheelchair to make a 180-degree turn, using a clear space of 60 inches in diameter or a 60-inch by 60-inch T-shaped space. If a portable lift or stretcher will be needed, for example if exam table are not accessible, additional floor space will be required. Not every exam room needs to be accessible; however each *type* of room does need to be accessible. Moreover, if there are a limited number of accessible rooms, staff will need to ensure that patients who have need of accessible rooms are not forced to wait longer than other patients if those rooms are not reserved.

2) Accessible Medical Equipment:

³⁸⁸ Hoffman, J. M., Shumway-Cook, A., Yorkston, K. M., Ciol, M. A., Dudgeon, B.J., & Chan, L. *Association of mobility limitations with health care satisfaction and use of preventive care: A survey of Medicare beneficiaries*. Archives of Physical Medicine and Rehabilitation, Vol. 88, Issue 5, 583-588 (May, 2007).

³⁸⁹ DOJ/HHS Access to Medical Care guide. Available at: http://www.ada.gov/medcare_ta.htm.

Availability of accessible medical equipment is necessary to ensure people with disabilities receive comparable medical care. In many instances, for example, thorough medical exams require a patient to be lying down. Examining the patient in his/her wheelchair will limit the ability of the physician in these instances to accomplish a comparable thorough medical exam.³⁹⁰

In other instances, such as gynecological and radiologic examinations, specialized positioning is required. At the current time, federal requirements for accessible medical equipment are more flexible, but more specific requirements have been issued in draft form and are expected to be formalized.

An accessible exam table or chair should have at a minimum: (1) ability to lower to the height of the wheelchair seat, 17-19 inches, or lower, from the floor; and (2) elements to stabilize and support a person during transfer and while on the table, such as rails, straps, stabilization cushions, wedges, or rolled up towels.³⁹¹ The base will need to be clear and not protrude relative to the seat or other transfer position.

Even with accessible exam tables and other equipment, patients may need further assistance in transfers. This can be achieved through use of simple tools, such as transfer boards and gait belts or where more assistance is needed with patient lifts. These can be portable floor lifts, or integrated or free standing overhead lifts.³⁹²

³⁹⁰ *Id.*

³⁹¹ DOJ/HHS Access to Medical Care guide.

³⁹² *Id.*

Adjustable height stretchers can also be used as an interim step particularly when lifts cannot be used in conjunction with equipment such as radiologic equipment. In all instances, staff training in use of the medical and transfer equipment is necessary to ensure both patient and staff safety.³⁹³ In fact, failure to use a lift, a gait belt, and multiple assistants during a transfer of a person in need of transfer assistance may constitute medical malpractice.³⁹⁴

Radiologic equipment may or may not be able to adjustable depending on the nature of the equipment. Tables used for x-ray exams are available in adjustable height models and accessible mammography equipment is available.³⁹⁵ Other equipment, such as MRI and CT, may require more reliance on lifts and other transfer assistance. Adequate floor space to accommodate these is essential. Staff should be trained to provide support pillows, rolled up towels, wedges, and so forth, to accommodate positioning needs and address issues such as spasticity, tremor and other conditions.

Providers should have wheelchair-accessible scales. Accurate weight information is critical to various aspects of medical care used for diagnosis and treatment.³⁹⁶

B. Communications/Changes to Practices/Policies for Patients with Auditory Disabilities

³⁹³ *Id.*

³⁹⁴ See *Myrtis Hill v. Fairfield Nursing and Rehabilitation Center LLC, et al.*, No. CV-06-1266, 2012 WL 5077166 (Ala. Oct. 19, 2012)(not designated for publication)(Plaintiff's expert, a nurse, established that standard of care required use of a lift or a gait belt and two assistants in transferring an 85 year old nursing home resident and that the failure to do so was a cause of the plaintiff's fall and leg fracture) . Available at: <http://alabamaappellatewatch.com/wp-content/uploads/2012/10/10905491.pdf>.

³⁹⁵ DOJ/HHS Access to Medical Care guide.

³⁹⁶ *Id.*

Section 504 of the Rehabilitation Act of 1973 and the ADA require the provision of interpreter services to achieve effective communication when communicating with patients or family members of patients with hearing disabilities.³⁹⁷ Where information is presented in written form to patients who have visual disabilities, effective communication may require alternative formats or other assistance. “Effective communication is particularly critical in health care settings where miscommunication may lead to misdiagnosis and improper or delayed medical treatment.”³⁹⁸

As with other communication issues under the ADA, the required communications accommodations will vary depending on the situation. For patients with hearing disabilities:

Written forms or information sheets may provide effective communication in situations where there is little call for interactive communication, such as providing billing and insurance information or filling out admission forms and medical history inquiries.

For more complicated and interactive communications, such as a patient’s discussion of symptoms with medical personnel, a physician’s presentation of diagnosis and treatment options to patients or family members, or a group therapy session, it may be necessary to provide a qualified sign language interpreter or other interpreter.³⁹⁹

³⁹⁷ See *ADA Business BRIEF: Communicating with People Who Are Deaf or Hard of Hearing in Hospital Settings*, U.S. Department of Justice, Civil Rights Division, Disability Rights Section (DOJ Hospital Hearing Brief). Available at: <http://www.ada.gov/hospcombr.htm>. See also Chilton EE. *Ensuring effective communication: the duty of health care providers to supply sign language interpreters for deaf patients*. *Hastings L.J.*, 1996; 47:871-910.

³⁹⁸ DOJ Hospital Hearing Brief.

³⁹⁹ *Id.*

The type of qualified interpreter will depend predominately upon the communication needs of the patient with a disability and the situation. Individuals with hearing disabilities have different communication skills and the provider should consult with each individual to determine what aids or services are necessary to provide effective communication in particular situations.⁴⁰⁰ Some situations will call for sign language interpreters, oral interpreters,⁴⁰¹ a cued speech interpreter,⁴⁰² or use of Computer Assisted Real-time Transcription (CART).⁴⁰³

Situations where an interpreter may be required for effective communication include:

- discussing a patient’s symptoms and medical condition, medications, and medical history;
- explaining and describing medical conditions, tests, treatment options, medications, surgery and other procedures;
- providing a diagnosis, prognosis, and recommendation for treatment;
- obtaining informed consent for treatment;
- communicating with a patient during treatment , testing procedures, and during physician’s rounds;
- providing instructions for medications, post-treatment activities, and follow-up treatments;
- providing mental health services, including group or individual therapy, or counseling for patients and family members;
- providing information about blood or organ donations;
- explaining living wills and powers of attorney;
- discussing complex billing or insurance matters; and,
- making educational presentations, such as birthing and new parent classes, nutrition and weight management counseling, and CPR and first aid training.⁴⁰⁴

⁴⁰⁰ *Id.*

⁴⁰¹ Oral interpreters are specially trained to articulate speech silently and clearly, sometimes rephrasing words or phrases to give higher visibility on the lips. Natural body language and gestures are also used. See *Id.*

⁴⁰² A cued speech interpreter functions in the same manner as an oral interpreter except that he or she also uses a hand code, or cue, to represent each speech sound. See *Id.*

⁴⁰³ Many people who are deaf or hard of hearing are not trained in either sign language or speech reading. CART is a service in which an operator types what is said into a computer that displays the typed words on a screen. See *Id.*

⁴⁰⁴ See *Id.*

C. HIV

HIV/AIDS constitutes a disability under the ADA.⁴⁰⁵ In the medical care setting, the ADA prohibits refusals to treat a patient because of his/her infection with HIV, or otherwise discriminate against the patient in the full and equal enjoyment of the goods, services, facilities, privileges, advantages, and accommodations of the facility in violation of the ADA.⁴⁰⁶

Categorical refusals to treat, and referrals to other facilities when the original health care provider is otherwise qualified to provide a particular health care service, are prohibited by the ADA.⁴⁰⁷ Fear of acquiring HIV from a patient, (i.e., considering a patient with HIV/AIDS as a direct threat) is generally prohibited.⁴⁰⁸

Persons with HIV or AIDS will rarely, if ever, pose a direct threat in the public accommodations context. ... A gynecologist's refusal to treat a woman with HIV would be a violation of the ADA. Health care providers are required to treat all persons as if they have HIV or other blood-borne pathogens, and must use universal precautions (gloves, mask, and/or gown where appropriate, etc.) to protect themselves from the transmission of infectious diseases. Failure to treat a person who discloses that she has HIV out of a fear of contracting HIV would be a violation of the ADA, because so long as the physician utilizes universal precautions, it is generally safe to treat persons with HIV or AIDS.

⁴⁰⁵ See *Bragdon v. Abbott, et al.*, 524 U.S. 624 (1998). See also, the ADA Amendments Act of 2008, Pub. L. No. 110-325, 122 Stat. 3553 (codified in scattered sections of 42 U.S.C.) (under which people with HIV/AIDS can demonstrate that they are disabled simply by showing that their unmedicated HIV/AIDS substantially limits the functions of their immune system).

⁴⁰⁶ See 42 U.S.C. § 12182, and the relevant implementing regulation, 28 C.F.R. Part 36. While denial of service may violate other statutes, and may constitute medical malpractice, our primary focus in this report is on the ADA and Section 504.

⁴⁰⁷ See Questions and Answers: The Americans with Disabilities Act and Persons with HIV/AIDS, U.S. Dept. of Justice. Available at: https://www.ada.gov/hiv/ada_qa_hiv.htm.

⁴⁰⁸ See *Id.*

Refusals to treat because of a patient’s HIV status have formed the basis for federal enforcement actions against health care providers. For example, the DOJ has settled cases brought against a bariatric surgery center where it allegedly refused to perform bariatric surgery in its surgical facility instead of hospital.⁴⁰⁹

In another case, the DOJ settled with a pain treatment center for alleged refusal to treat a patient with HIV who presented with severe back pain.⁴¹⁰ In a third recent case, after learning that new patient was HIV+, a dentist agreed to treat the patient, but required the patient to schedule all future visits at the last appointment time of the day.⁴¹¹ In all three cases, the health care facilities agreed to adopt formal policies prohibiting discrimination on the basis of HIV, monitoring and reporting to the DOJ, and financial damages to be paid to the complainants.

D. Other Programmatic Issues

Programmatic access to healthcare requires that the policies and practices that are part of the delivery of healthcare do not hinder the ability of patients with disabilities to receive the same quality of care as other persons.⁴¹² Requirements will vary depending on an individual

⁴⁰⁹ See Settlement Agreement between the United States of America and Barix Clinics, July 26, 2013. Available at: <http://www.ada.gov/Barix-clinic.htm>.

⁴¹⁰ See Settlement Agreement between the United States of America and Fayetteville Pain Center, January 30, 2013. Available at: http://www.ada.gov/fayetteville_pain_ctr_settle.htm.

⁴¹¹ See Settlement Agreement between the United States of America and Woodlawn Family Dentistry, January 30, 2013. Available at: http://www.ada.gov/woodlawn_fmly_dnst.htm.

⁴¹² Nancy R. Mudrick & Sylvia Yee, *Defining Programmatic Access to Healthcare for People with Disabilities* (“Defining Programmatic Access”), DREDF, Spring, 2007. Available at: <http://dredf.org/healthcare/Healthcarepgmaccess.pdf>.

patient's needs due to his/her disability and the medical situation presented. As a general matter, practitioners should be guided by the patient's requests for assistance.⁴¹³

For example, for patients with visual disabilities, providers will need to determine appropriate modifications to practices and procedures when dealing with patients who are blind or with more limited visual impairments and what auxiliary aids and services to utilize. Auxiliary aids and services include, but are not limited to, readers, taped texts, braille materials, and the acquisition or modification of equipment.⁴¹⁴

The American Foundation for the Blind suggests providers consider the following issues:

- Identifying personnel.
- Reviewing documents.
- Counting and identifying currency; credit cards; signatures.
- Sighted guide technique and mobility aids.
- Verbalizing directions.
- Using disability-sensitive language and etiquette.
- Communicating with persons who are deaf-blind.
- Accommodation of Dog guides.
- Identifying visual acuity.
- TDDs for patients who are deaf-blind.
- Verbalizing or demonstrating procedures before they are performed.
- Customizing treatment and discharge plans.
- Identifying medication.
- Food service assistance.
- Accessible signage and other ADAAG requirements.
- Identify potential problems that are not reflected in the ADAAG (such as inadequate lighting, glare, and interference from white noise and other masking sounds).
- Identifying community-based programs.

⁴¹³ See Scott Marshall and Elga Joffe, *ADA Checklist: Health Care Facilities and Service Providers. Ensuring Access to Services and Facilities by Patients Who Are Blind, Deaf-Blind, or Visually Impaired.* ("AFB ADA Checklist.") American Foundation for the Blind. Available at: <https://www.afb.org/blindness-and-low-vision/your-rights/advocacy-resources/ada-checklist-health-care-facilities-and>.

⁴¹⁴ Id..

Chapter 12 – Health Care

Using a checklist like this is useful when considering appropriate and necessary modifications to policies and procedures for other types of disabilities.

Researchers at DREDF suggest medical practitioners consider the following issues:⁴¹⁵

Components of Programmatic Access to Healthcare for People with Disabilities

Policies for Communication & Access to Information	
Policy or Procedure	Rationale or Method
Provisions for intake forms to be completed by persons with visual impairments with the same confidentiality afforded other patients	Use of large print forms, electronic or online web-based forms, or in-person staff assistance in a private location
Provision for the presence of sign language interpreters to enable full communication with deaf patients who use sign language	Professionalism and confidentiality require that the healthcare provider take responsibility for the communication
Provisions for making auditory information (e.g., automated phone menus or messages) available via alternative means	Written communication or secure web-based methods are possible substitutes
Provisions for communicating with deaf patients by telephone.	Use of the telephone relay service (TRS), a TDD, or use of secure electronic means
Policies for Scheduling and Waiting	
Policy or Procedure	Rationale or Method
Policies that allow scheduling additional time for the duration of appointments for patients with disabilities who may require it	Patients may require more time than standard because of complexities associated with the interaction of a non-disability-related medical condition with the existing impairment or disability. More time may be needed to conduct the examination or for communication through an interpreter or because of other communication issues.
Policies to enable patients who may not be able to tolerate waiting in a reception area to be seen immediately upon arrival	Patients with cognitive, intellectual or some psychiatric disabilities may be unable to wait in a crowded reception area without becoming agitated or anxious.
Policies to allow flexibility in appointment times for patients who use paratransit	Patients may arrive late at appointments because of delays or other problems with paratransit scheduling and reliability
Policies to enable compliance with the federal law that guarantees access to medical offices for people with disabilities who use service animals	Patients with service animals expect the animal to accompany them into the waiting and examination rooms, and this is a protected right under the Americans with Disabilities Act. A policy enables medical offices to be prepared to respond appropriately to the needs of all patients.

⁴¹⁵ Defining Programmatic Access. Available at: <http://dredf.org/healthcare/Healthcarepgmaccess.pdf>.

Procedures for Conducting the Examination	
Policy or Procedure	Rationale or Method
Training nurses and medical staff to safely assist or lift patients from wheelchairs to examination tables or equipment, and return them safely after the exam. Training to appropriately help a patient who may need assistance with dressing both before and at the conclusion of the exam	Training will reduce the likelihood of injury to the patient or to the medical personnel providing assistance, and ensure that a comprehensive examination can be conducted
Ability to identify the need for equipment to assure an exam or procedure can be fully conducted; knowledge about purchasing accessible equipment, repairing or replacing it	Special equipment (e.g., for lifting, weighing, or examining a patient) may make thorough exams possible and better for both patient and provider.
Training of doctors, nurses, and other medical staff in the operation of accessible equipment	Medical office staff must know how to operate the accessible equipment, such as adjustable height exam tables and mammography machines and weight scales, so they can be regularly and easily utilized.
Training of doctors, nurses, and other office staff for disability cultural competence--knowledge regarding how to treat a patient with a disability with dignity and respect, and knowledge of how disability may affect the provision of medical treatment for primary and other care.	Stereotypes regarding whether people with disabilities experience pain or are capable of making medical decisions have resulted in deficient treatment. Providers may fail to speak directly to the patient, may not provide for privacy, or may make incorrect assumptions.
Plan for emergency evacuation of patients includes evacuation procedures for people with disabilities	Evacuation plans should cover procedures for people who may need assistance in exiting the facility under extraordinary conditions.
Healthcare System-wide Issues	
Policy or Procedure	Rationale or Method
Ability to provide healthcare through flexibility or creativity to overcome barriers resulting from system-wide policies or practices	Where services may need to be delivered in an atypical venue (e.g., teeth cleaning under general anesthesia), system-wide policies and/or coordination is required to ensure access

E. Accessibility of Electronic Health Records

The Promoting Interoperability Programs (formerly Medicare Electronic Health Record (HER) Incentive Program) provides incentive payments to eligible professionals, eligible hospitals, and critical access hospitals that demonstrate “meaningful use” of certified EHR

technology.⁴¹⁶ Providers need to establish certain features to demonstrate the required “meaningful use” to qualify.

The implementing regulations require that patients have access to their health records, and adopt Web Content Accessibility Guidelines (WCAG) 2.0, Level A Conformance [introduced earlier, as updated as WCAG 2.1] as the required standard.⁴¹⁷ Providers must have this in place beginning with the EHR reporting periods in fiscal year and calendar year 2014.⁴¹⁸ This is a separate, more specific mandate than the more general (at least current) requirement for government web site accessibility under the ADA.

II. Sioux Falls Compliance

The Health Department provides medical care through the Falls Community Health (FCH) program and clinic. It treats approximately 13,000 patients per year. FCH provides care paid for by Medicaid, Medicare, private insurance and services billed and a sliding fee schedule based on income.

FCH provides a broad spectrum of care including:

- Medical care - Acute care, Routine Visits, Screening, Immunizations, Well Checks, and ongoing care for chronic illness.
- Lab Testing.
- X-rays.
- Counseling.
- Routine Dental Care.

⁴¹⁶ See *Promoting Interoperability Programs*, Centers for Medicare & Medicaid Services. Available at: <https://www.cms.gov/regulations-and-guidance/legislation/ehrincentiveprograms> .

⁴¹⁷ *Health Information Technology: Standards, Implementation Specifications, and Certification Criteria for Electronic Health Record Technology, 2014 Edition; Revisions to the Permanent Certification Program for Health Information Technology*, Dept. of Health and Human Services, 45 CFR Part 170, 170.204, 77 Fed. Reg. 54163, 54284 (RIN 0991–AB82), Sept. 4, 2012 (Effective Oct. 4, 2012). Available at: <http://www.gpo.gov/fdsys/pkg/FR-2012-09-04/pdf/2012-20982.pdf>.

⁴¹⁸ *Id.*, 77 Fed. Reg. 54163.

- Dental Emergency Walk-ins.
- Nurse Case Management.
- Social Work.
- HIV Testing and Care.

FCH has six doctors, mental health counselor, and supporting staff. It provides care at two school centers in conjunction with the schools. The main FCH clinic downtown was renovated in 2007 and is ADA compliant in construction. FCH uses two vans to provide transport for some patients. These are not accessible, but FCH coordinates paratransit scheduling for patients who need it.

FCH has a policy for addressing issues related to disability, and relies on the medical training and experience of its practitioners.⁴¹⁹ The health care board has members on it who are people with disabilities. The City and the authors have provided in-service training sessions to FCH staff regarding provision of accessible medical services.

The City ADA Coordinator and a Health Department employee provide other FCH employees with ADA training which has included: (1) interacting/communicating with people with disabilities; (2) accommodations; (3) two-person transfer; (4) information on accessible equipment; (5) documentation of accessibility needs, including if an interpreter is needed; and (6) ensuring access for all.⁴²⁰

FCH relies on the City's contract for sign language translators when necessary. FCH documents alerts in the electronic patient record if an accommodation is known and needed.

⁴¹⁹ See Appendix 18, Sioux Falls Health Department—Falls Community Health Standard Operating Policy/Procedure for ADA: Providing Care to Individuals with Disabilities (FCH ADA Policies).

⁴²⁰ Communication with Colleen Moran, the former ADA Coordinator.

For instance, if a deaf interpreter is needed, FCH staff is able to add a “pop-up” alert in the record that is visible to staff who are scheduling the patient. FCH staff documents in the appointment notes if an interpreter is needed, and if it was scheduled.

FCH is in the process of creating a system of electronic health records, and the EHR’s will have a patient portal. FCH uses eClinicalWorks version 11, which is certified as a qualified and accessible product.⁴²¹

FCH does not discriminate against patients with HIV/AIDS, and has programs for free, rapid HIV testing, and HIV/AIDS early intervention services and case management.⁴²² FCH is a provider of HIV/AIDS services under the Ryan White CARE Act.⁴²³

The City is also establishing a Community Triage Center known as the Link in partnership between the City, Minnehaha County, Avera Health, and Sanford Health that will offer assistance and serve as a first point of contact for individuals seeking mental health care or addiction counseling. It is expected to open 2021.⁴²⁴

III. Recommendations

Review of the main FCH clinic found the facility generally ADA compliant. Some of the exam rooms are of adequate size to provide accessible care. However, at the time of our review in 2012, no exam rooms had accessible exam tables. The radiologic table was adjustable height

⁴²¹ See Certified Health IT Product List. Available at <https://chpl.healthit.gov/#/listing/9263>.

⁴²² See FCH website. Available at: <https://www.siouxfalls.org/health/falls-community-health/hiv-aids/your-rights>.

⁴²³ See FCH website. Available at: <https://www.siouxfalls.org/health/falls-community-health/hiv-aids>.

⁴²⁴ See <https://www.siouxfalls.org/news/2020/08/26/gift>. And see <https://www.minnehahacounty.org/ctcp/reports/Community%20Triage%20Center%20Conceptual%20Plan.pdf>.

and the mammography equipment is accessible. The dental chairs lower to an adequate height, but the base of the chairs protrudes in a manner that may hinder transfers.

In response to our observations, the City Council approved funding in 2013-2014 to expand access equipment at FCH. A lift was purchased to assist in transfers to dental chairs, radiological equipment and the like. FCH has purchased two accessible medical exam tables and a wheelchair accessible scale in 2014. FCH managers have stated they will ensure staff are trained in how to use the tables. Other equipment, including gait belts, has been acquired.

While we provided some ideas to staff on providing accessible medical care, FCH should develop written policies, instructions and formal training to assist staff in providing equitable health care. As noted, the City ADA Coordinator and Clinic staff provide training to the staff. Staff have produced a basic ADA policy to help instruct staff. Because programmatic issues related to disability are complicated, documented policies and adequate training for a diverse staff can help to better ensure equitable treatment. FCH Staff may find it beneficial to expand on this training and written policy over time to add more detail to ensure that services are provided equitably.

I. Federal Requirements

The right to vote is a fundamental right.⁴²⁵ “No right is more precious in a free country than that of having a voice in the election of those who make the laws under which, as good citizens, we must live. Other rights, even the most basic, are illusory if the right to vote is undermined.”⁴²⁶

As with other governmental services, the ADA and Section 504 prohibit discrimination in voting. As the DOJ notes in a brief addressing barriers to voting in New York City:

Congress specifically found that discrimination against individuals with disabilities persists in many critical areas, including voting. 42 U.S.C. § 12101(a)(3); see also S. Rep. No. 101-116, at 110 (1989) (citing testimony about state discrimination in making polling places accessible and forcing votes by absentee ballot before key candidate debates). Congress, therefore, clearly enacted Title II with the intent to eliminate discrimination in voting by ensuring physical access to polling places for individuals with disabilities.⁴²⁷

To avoid discrimination against voters with disabilities, public entities must ensure they choose: (1) accessible polling places, and (2) accessible voting systems.

Relevant to choosing voting sites, the DOJ observes in its *DIA v. New York City* brief that ADA regulations provide “that public entities ‘may not, in determining the site or location of a facility, make selections’ that ‘have the effect of excluding individuals with disabilities from,

⁴²⁵ *Reynolds v. Sims*, 377 U.S. 533, 562 (1964).

⁴²⁶ *Id.*, 377 U.S. 533, 560 (1964).

⁴²⁷ Brief for the United States of America as Amicus Curiae in Support of Affirmance, *Disabled in Action and United Spinal Assn. v. Board of Elect. in the City of New York and Frederic M. Umame*, 2nd Cir., Civ. 12-4412 at p. 14-15. Filed Aug. 14, 2013. (“DOJ *DIA v. New York City* Brief.”) Available at: <http://www.ada.gov/briefs/BOE-newyork-amicus.doc>.

denying them the benefits of, or otherwise subjecting them to discrimination’ under a public program.”⁴²⁸ The DOJ has published a useful checklist for public entities to use in evaluating and selecting accessible polling places.⁴²⁹

Section 301 of the Help America Vote Act (HAVA),⁴³⁰ requires that public entities have voting systems for use in federal elections that comply with the accessible voting system standards set forth in that Section in place by January 1, 2006. While HAVA is not specifically at issue in non-federal elections, public entities are nevertheless required to have some mechanism to allow accessible voting under the program access requirements of the ADA. Use of accessible voting technology that complies with HAVA would be one way for public entities to comply with their ADA Title II program access requirements.

Adequate training and supervision of poll workers is essential to ensure fair and equitable elections, including ensuring no discrimination occurs as a result of disability. Staff need to be able to set-up and ensure proper functioning of voting machines generally, including accessible voting technologies. Staff need to ensure that items such as voting machines and temporary furniture are appropriately spaced to ensure accessible paths of travel.

“The accessible voting area must be on an accessible route and have an accessible entrance and adequate circulation and maneuvering space for voters who use wheelchairs or

⁴²⁸ *Id.* at p. 15. Citing 28 C.F.R. § 35.130(b)(4); accord 28 C.F.R. § 41.51(b)(4) (same, under Rehabilitation Act).

⁴²⁹ See ADA Checklist for Polling Places. Available at: <http://www.ada.gov/votingck.htm>.

⁴³⁰ Help America Vote Act of 2002 (HAVA), Pub. L. No. 107-252, 116 Stat. 1666-1730 (2002), I at 42 U.S.C. §§ 15301-15545, 15481 ("HAVA Section 301").

scooters or who walk with mobility aids.”⁴³¹ “[P]edestrian routes open to voters serving or leading to the voting area, such as hallways, corridors and the voting space, must be free of objects that cannot be detected by a person who is blind or visually impaired.”⁴³² These areas must be clear in all public areas, not just on the accessible route. Moreover, the increasing complexity of voting systems, including accessible voting technology, requires additional training and effective execution.⁴³³

II. Federal Enforcement

Federal and private party actions to ensure non-discrimination in voting have focused on polling place accessibility and availability of accessible voting technology.

The majority of enforcement actions have focused on polling place accessibility. The DOJ filed an amicus brief in support of a private lawsuit challenging inaccessible polling places in New York City.⁴³⁴ The federal District Court in the case held that the New York City board of elections discriminated based on disability by failing to address barriers to access at New York City polling places.⁴³⁵

⁴³¹ ADA Checklist for Polling Places at p. 32. Available at: <http://www.ada.gov/votingscrn.pdf>.

⁴³² *Id.*, at p. 29.

⁴³³ See *Helping Americans Vote: Poll Workers*, The Pew Center on the States, Sept. 2007. Available at: https://www.pewtrusts.org/-/media/legacy/uploadedfiles/wwwpewtrustsorg/reports/election_reform/eripbrief19finalpdf.pdf.

⁴³⁴ See DOJ *DIA v. New York City* Brief. Available at: <http://www.ada.gov/briefs/BOE-newyork-amicus.pdf>.

⁴³⁵ *United Spinal Association et al. v. Board of Elections in the City of New York et al.*, No. 10-cv-5653 (S.D. N.Y., 2012).

DOJ has also has settled numerous claims regarding polling place accessibility and requiring modification under its Project Civic Access program.⁴³⁶ These settlements have required localities to select accessible polling places and have directed the localities to utilize the DOJ ADA Checklist for Polling Places.⁴³⁷

The DOJ filed a complaint against the State of Maine alleging violations of HAVA requiring that each polling place have a voting system accessible to voters with disabilities.⁴³⁸ The federal court approved a consent decree between the Department and the State.⁴³⁹ The DOJ filed a similar suit against New York State and settled that aspect of the suit.

Various private groups have filed suits under the ADA, Section 504 and HAVA to ensure the availability of accessible voting technology. The DOJ has filed amicus briefs supporting plaintiffs in some of these cases.⁴⁴⁰

In one case, a federal District Court held that the covered entity must “provide meaningful access to private and independent voting ... and must provide auxiliary aids ‘where

⁴³⁶ See, e.g., Settlement Agreement between the United States and the City of Independence, Kansas, Apr. 29, 2011. Available at: http://www.ada.gov/independence_ks/independenceks_sa.htm. See also Settlement Agreement between the United States and the Van Buren County, Arkansas, June 28, 2011. Available at: http://www.ada.gov/van_buren_pca/van-buren_sa.htm.

⁴³⁷ ADA Checklist for Polling Places at p. 32. Available at: <http://www.ada.gov/votingscrn.pdf>.

⁴³⁸ Complaint, *United States v. Maine*, Civ. No. 06-86-B-W (D. Me. 2006). Available at: http://www.justice.gov/crt/about/vot/hava/maine_comp.php.

⁴³⁹ Consent Decree, *United States v. Maine*, Civ. No. 06-86-B-W (D. Me. 2006). Available at: http://www.justice.gov/crt/about/vot/hava/maine_cd.php.

⁴⁴⁰ See Brief of DOJ in *American Ass’n of People with Disabilities v. Holland* (AAPD. v. Holland), 647 F.3d 1093 (11th Cir. 2011). In the underlying case, *American Ass’n of People with Disabilities v. Stafford*, 310 F. Supp. 2d 1226, 1235 (M.D. Fla. 2004), the district court held that a voting system is a “facility” under DOJ regulation 28 C.F.R. 35.151(b) which requires any public entity altering a facility do so to the maximum extent feasible, and that the county’s purchase of less accessible voting equipment constituted discrimination. A panel of the Eleventh Circuit held that voting machines are not “facilities” under the regulation despite the DOJ’s brief. Available at: http://www.justice.gov/crt/about/app/briefs/holland_brief.pdf.

necessary to afford individuals with disabilities ... an equal opportunity to participate in, and enjoy the benefits of, a service, program, or activity of a public entity.”⁴⁴¹ The *Alameda County* court’s reasoning seems more persuasive than the Eleventh Circuit’s in *AAPD v. Holland*, and is supported by the DOJ.

III. Sioux Falls Compliance

Poll worker training includes hands-on setup of ballot marking devices, placement of the device, and placement of accessible paper ballot voting booths. In addition to the training, workers are furnished with an “election day precinct manual” that includes, among other things, a checklist for proper setup and use of assistive devices and booths.

A comprehensive review of polling place accessibility has not been performed in over five years, but a review of exterior accessibility was conducted in July 2020 by the PAVA lead for Disability Rights South Dakota. In the event new locations must be chosen for an election, careful attention is given to overall accessibility both inside and outside the polling place. Most polling locations are non-public facilities (most often places of worship).

Sioux Falls began using electronic ballot marking devices (AutoMark) in approximately 2006. In 2018, the AutoMark was replaced with the ExpressVote ballot marking device. One device is deployed to every polling location for Election Day and one is available throughout the in-person absentee voting period at the absentee precinct (typically the County Auditor’s Office.) In 2018, the City was the first jurisdiction in the state to deploy the ExpressVote on an

⁴⁴¹ *California Council of the Blind, et al., v. County of Alameda*, p. 10-11, Civ. No. 13-cv-03443-JCS., N.D. Cal. (Oct. 24, 2013). (Citing 28 C.F.R. § 35.160(b)(1).) Available at <https://casetext.com/case/cal-council-of-the-blind-v-cnty-of-alameda-1>.

extensive scale. In preparation for the deployment, significant outreach was done with local non-profit organizations to educate users and solicit feedback/advice on deployment. While the ExpressVote user interface is not vastly different from the AutoMark, it tends to be significantly easier for poll workers to set up. On each Election Day, City staff are available to assist with setup as needed.

In 2014, we utilized the DOJ ADA Checklist for Polling Places as a guide. We found all but one of the sites to satisfy the requirements in the Checklist at the time of the review. (Sites will need to be evaluated at the time of an election to ensure they remain accessible as, for example, weather may lead to erosion of sidewalks and create cracks over time.)

IV. Recommendations

The City should continue its evaluations to ensure polling places are in fact accessible on Election Day. This is made easier by using checklists for staff at each polling place to be able to go through and ensure that polling places are set-up properly. Such a list would augment general poll worker training, and would, for example, note the problems at particular polling places discussed above that need to be resolved; that tables need to be spaced appropriately, to check that the ExpressVote devices are set up, to ensure that other temporary elements are detectable by voters with visual disabilities, and the like. The City should then document and evaluate errors to ensure that they do not recur in future elections.

Appendices:

Appendix 1: Statutory and Regulatory Excerpts.

Appendix 2: Documents Reviewed (Illustrative).

Appendix 3: On Time Performance Data.

Appendix 4: Monthly bus driver training minutes.

Appendix 5: Ramps Installed – Overlays and Reconstructions.

Appendix 6: Sioux Falls 2017 Updated Parks Department Transition Plan and Selected Documents.

Appendix 6 (A): 2002 ADA Transition Plan- updated 2017.pdf.

Appendix 6 (B): ADA- 2019 project scope.pdf.

Appendix 6 (C): ADA Accessibility Review Board Minutes- July 25- 2017.

Appendix 6 (D): Capital Program 2019 – 2023- p. 114- ADA Transition Plan Improvements.

Appendix 7: City of Sioux Falls Parks Department ADA Related Policies.

Appendix 8: Sioux Falls Executive Orders and Policies Regarding Disability.

Appendix 9: InterpreCorps, LLC, and Communication Service for the Deaf Contracts.

Appendix 10: 211 Help Line Contract.

Appendix 11: Sample Web Accessibility Report.

Appendix 12: Emergency Preparedness Efforts for those with Disabilities.

Appendix 13: Emergency Planning Maps Regarding Disability.

Appendix 14: Emergency Planning: Region 3 At Risk Populations: Community-Based Organizations.

Appendix 15: Sioux Falls Animal Emergency Response Plan.

Appendix 16: Sioux Falls Police Department Policies Regarding Disability.

Appendices

Appendix 17: Documents Related to Crisis Intervention Teams

Appendix 18: Sioux Falls Health Department—Falls Community Health Standard Operating Policy/Procedure for ADA: Providing Care to Individuals with Disabilities.

Appendix 19: Author Bios, About the Blanck Group, LLC.

Appendix 1: Statutory and Regulatory Excerpts

I. Americans with Disabilities Act (ADA) – Department of Justice Regulations

ADA title II creates requirements for public entities generally. These are reinforced by U.S. Department of Justice Regulation requirements for public entities including:

- to conduct a self-evaluation of its services, policies, and practices by July 26, 1992, and make modifications necessary to comply with the Department's title II regulation, 28 C. F. R. § 35. 105;
- to notify applicants, participants, beneficiaries, and other interested persons of their rights and the City's obligations under title II and the Department's regulation, 28 C. F. R. § 35. 106;
- to designate a responsible employee to coordinate its efforts to comply with and carry out the City's ADA responsibilities, 28 C. F. R. § 35. 107(a);
- to establish a grievance procedure for resolving complaints of violations of title II, 28 C. F. R. § 35. 107(b);
- to operate each program, service, or activity so that, when viewed in its entirety, it is readily accessible to and usable by individuals with disabilities, 28 C. F. R. §§ 35. 149 - 35. 150, by:
 - delivery of services, programs, or activities in alternate ways, including, for example, redesign of equipment, reassignment of services, assignment of aides, home visits, or other methods of compliance or, if these methods are not effective in making the programs accessible;
 - physical changes to buildings (required to have been made by January 26, 1995), in accordance with the Department's title II regulation, 28 C. F. R. §§ 35. 150 and 35. 151, and the ADA Standards for Accessible Design (Standards), 28 C. F. R. pt. 36, App. A, or the Uniform Federal Accessibility Standards (UFAS), 41 C. F. R. § 101-19. 6, App. A.
- to ensure that facilities for which construction or alteration was begun after January 26, 1992, are readily accessible to and usable by people with disabilities,

in accordance with 1) the Department's title II regulation and 2) the Standards or UFAS, 28 C. F. R. § 35. 151;

- to ensure that communications with applicants, participants, and members of the public with disabilities are as effective as communications with others, including furnishing auxiliary aids and services when necessary (This section, and others require that the City's and SAM's web sites are accessible to people with communication or other disabilities that impact their ability to use these websites.), 28 C. F. R. § 35. 160;¹
- to provide direct access via TTY (text telephone) or computer-to-telephone emergency services, including 9-1-1 services, for persons who use TTY's and computer modems, 28 C. F. R. § 35. 162;
- to provide information for interested persons with disabilities concerning the existence and location of the City's accessible services, activities, and facilities, 28 C. F. R. § 35. 163(a); and,
- to provide signage at all inaccessible entrances to each of its facilities, directing users to an accessible entrance or to information about accessible facilities, 28 C. F. R. § 35. 163(b).

II. Americans with Disabilities Act (ADA) – Department of Justice Regulations

- Updated ADA Standards
 - The DOJ updated standards in 2004 and 2010. The 2004 ADAAG, 36 C. F. R. § 1191, Appendix D ("2004 ADAAG") is the current primary design standard, with a few changes. For new and substantially altered construction after November 29, 2006, the following standards are notable:

2004 ADAAG 810.2 Bus Boarding and Alighting Areas. Bus boarding and alighting areas shall comply with 810.2.

¹ See also *Accessibility of State and Local Government Websites to People with Disabilities* (available at: www.ada.gov/websites2.htm).

Advisory 810.2 Bus Boarding and Alighting Areas. At bus stops where a shelter is provided, the bus stop pad can be located either within or outside of the shelter.

810.2.1 Surface. Bus stop boarding and alighting areas shall have a firm, stable surface.

810.2.2 Dimensions. Bus stop boarding and alighting areas shall provide a clear length of 96 inches (2440 mm) minimum, measured perpendicular to the curb or vehicle roadway edge, and a clear width of 60 inches (1525 mm) minimum, measured parallel to the vehicle roadway.

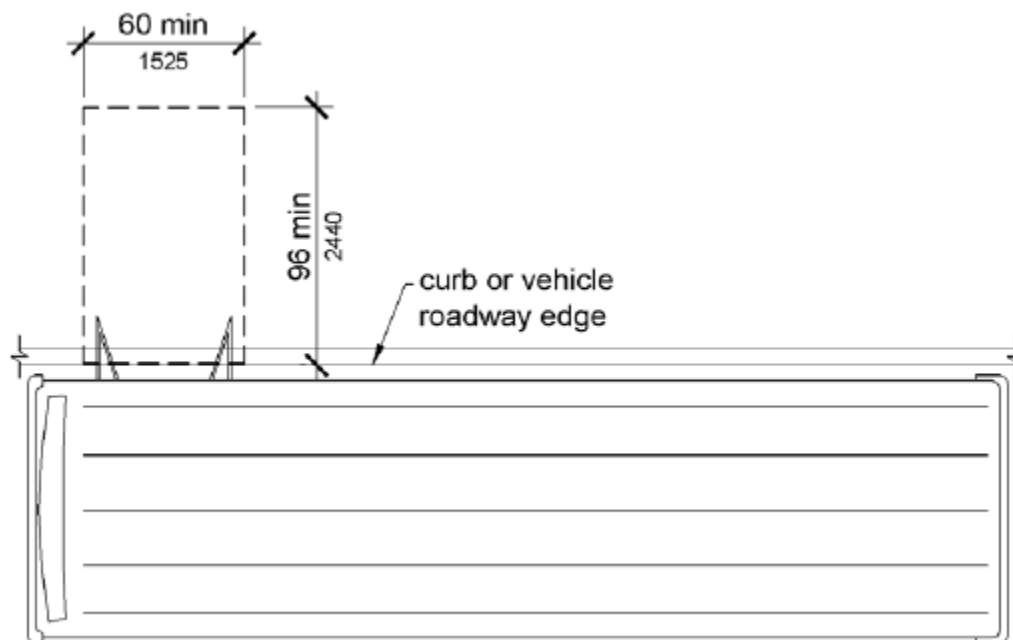

Figure 810.2.2 Dimensions of Bus Boarding and Alighting Areas

810.2.3 Connection. Bus stop boarding and alighting areas shall be connected to streets, sidewalks, or pedestrian paths by an accessible route complying with 402.

810.2.4 Slope. Parallel to the roadway, the slope of the bus stop boarding and alighting area shall be the same as the roadway, to the maximum extent practicable.

Perpendicular to the roadway, the slope of the bus stop boarding and alighting area shall not be steeper than 1:48.

810.3 Bus Shelters. Bus shelters shall provide a minimum clear floor or ground space complying with 305 entirely within the shelter. Bus shelters shall be connected by an accessible route complying with 402 to a boarding and alighting area complying with 810.2.

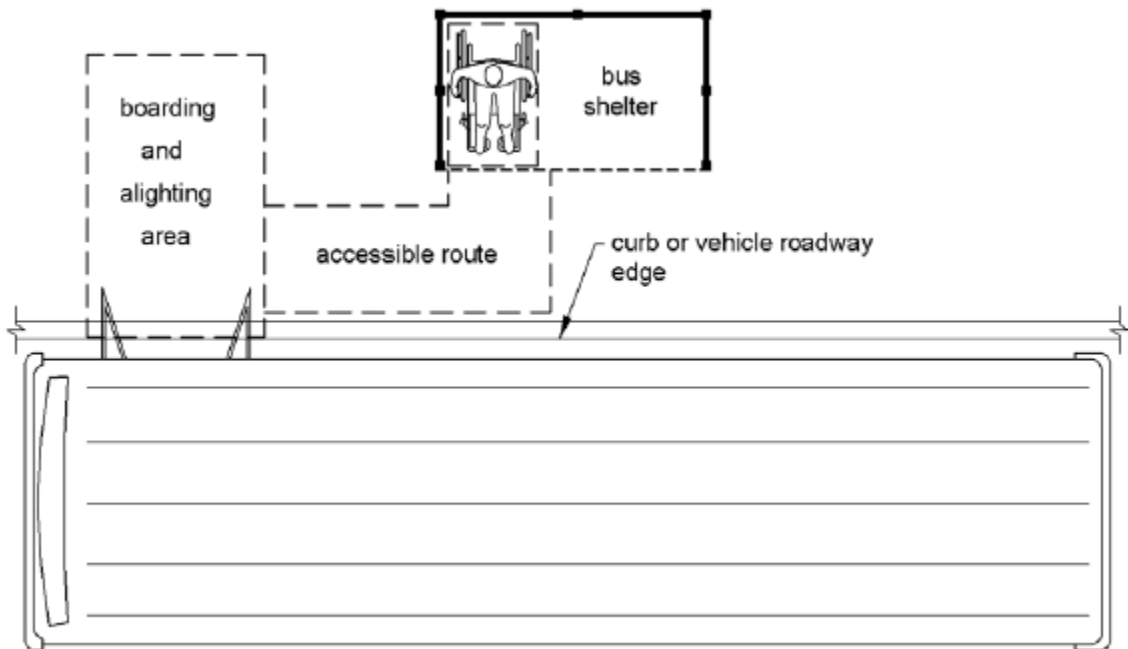

Figure 810.3 Bus Shelters

810.4 Bus Signs. Bus route identification signs shall comply with 703.5.1 through 703.5.4, and 703.5.7 and 703.5.8. In addition, to the maximum extent practicable, bus route identification signs shall comply with 703.5.5.

703.5.1 Finish and Contrast. Characters and their background shall have a non-glare finish. Characters shall contrast with their background with either light characters on a dark background or dark characters on a light background.

Advisory 703.5.1 Finish and Contrast. Signs are more legible for persons with low vision when characters contrast as much as possible with their background. Additional factors affecting the ease with which the text can be distinguished from its background include shadows cast by lighting sources, surface glare, and the uniformity of the text and its background colors and textures.

703.5.2 Case. Characters shall be uppercase or lowercase or a combination of both.

703.5.3 Style. Characters shall be conventional in form. Characters shall not be italic, oblique, script, highly decorative, or of other unusual forms.

703.5.4 Character Proportions. Characters shall be selected from fonts where the width of the uppercase letter "O" is 55 percent minimum and 110 percent maximum of the height of the uppercase letter "I".

EXCEPTION: Bus schedules, timetables and maps that are posted at the bus stop or bus bay shall not be required to comply.

Updated Communications Requirements (with updated text in bold):

Subpart E—Communications

§ 35.160 General.

(a)

(1) A public entity shall take appropriate steps to ensure that communications with applicants, participants, members of the public, **and companions with disabilities** are as effective as communications with others.

(2) For purposes of this section, “companion” means a family member, friend, or associate of an individual seeking access to a service, program, or activity of a public entity, who, along with such individual, is an appropriate person with whom the public entity should communicate.

(b)

(1) A public entity shall furnish appropriate auxiliary aids and services where necessary to afford qualified individuals with disabilities, **including applicants, participants, companions, and members of the public**, an equal opportunity to participate in, and enjoy the benefits of, a service, program, or activity of a public entity.

(2) The type of auxiliary aid or service necessary to ensure effective communication will vary in accordance with the method of communication used by the individual; the nature, length, and complexity of the communication involved; and the context in which the communication is taking place. In determining what types of auxiliary aids and services are necessary, a public entity shall give primary consideration to the requests of individuals with disabilities. **In order to be effective, auxiliary aids and services must be provided in accessible formats, in a timely manner, and in such a way as to protect the privacy and independence of the individual with a disability.**

(c)

(1) A public entity shall not require an individual with a disability to bring another individual to interpret for him or her.

(2) A public entity shall not rely on an adult accompanying an individual with a disability to interpret or facilitate communication except—

(i) In an emergency involving an imminent threat to the safety or welfare of an individual or the public where there is no interpreter available; or

(ii) Where the individual with a disability specifically requests that the accompanying adult interpret or facilitate communication, the accompanying adult agrees to provide such assistance, and reliance on that adult for such assistance is appropriate under the circumstances.

(3) A public entity shall not rely on a minor child to interpret or facilitate communication, except in an emergency involving an imminent threat to the safety or welfare of an individual or the public where there is no interpreter available.

(d) Video remote interpreting (VRI) services. A public entity that chooses to provide qualified interpreters via VRI services shall ensure that it provides—

(1) Real-time, full-motion video and audio over a dedicated high-speed, wide-bandwidth video connection or wireless connection that delivers high-quality video images that do not produce lags, choppy, blurry, or grainy images, or irregular pauses in communication;

(2) A sharply delineated image that is large enough to display the interpreter's face, arms, hands, and fingers, and the participating individual's face, arms, hands, and fingers, regardless of his or her body position;

(3) A clear, audible transmission of voices; and

(4) Adequate training to users of the technology and other involved individuals so that they may quickly and efficiently set up and operate the VRI.

2004 ADAAG (36 CFR part 1191, appendices B and D, adopted as part of both the Title II and Title III 2010 Standards).

Play areas.

105.2.3 ASTM. Copies of the referenced standards may be obtained from the American Society for Testing and Materials, 100 Bar Harbor Drive, West Conshohocken, Pennsylvania 19428 (<http://www.astm.org>).

ASTM F 1292-99 Standard Specification for Impact Attenuation of Surface Systems Under and Around Playground Equipment (see 1008.2.6.2).

ASTM F 1292-04 Standard Specification for Impact Attenuation of Surfacing Materials Within the Use Zone of Playground Equipment (see 1008.2.6.2).

ASTM F 1487-01 Standard Consumer Safety Performance Specification for Playground Equipment for Public Use (see 106.5).

ASTM F 1951-99 Standard Specification for Determination of Accessibility of Surface Systems Under and Around Playground Equipment (see 1008.2.6.1).

Advisory 105.2.3 ASTM. ASTM F 1292-99 and ASTM F 1292-04 establish a uniform means to measure and compare characteristics of surfacing materials to determine whether materials provide a safe surface under and around playground equipment.

These standards are referenced in the play areas requirements of this document when an accessible surface is required inside a play area use zone where a fall attenuating

surface is also required. The standards cover the minimum impact attenuation requirements, when tested in accordance with Test Method F 355, for surface systems to be used under and around any piece of playground equipment from which a person may fall.

ASTM F 1487-01 establishes a nationally recognized safety standard for public playground equipment to address injuries identified by the U.S. Consumer Product Safety Commission. It defines the use zone, which is the ground area beneath and immediately adjacent to a play structure or play equipment designed for unrestricted circulation around the equipment and on whose surface it is predicted that a user would land when falling from or exiting a play structure or equipment. The play areas requirements in this document reference the ASTM F 1487 standard when defining accessible routes that overlap use zones requiring fall attenuating surfaces. If the use zone of a playground is not entirely surfaced with an accessible material, at least one accessible route within the use zone must be provided from the perimeter to all accessible play structures or components within the playground.

ASTM F 1951-99 establishes a uniform means to measure the characteristics of surface systems in order to provide performance specifications to select materials for use as an accessible surface under and around playground equipment. Surface materials that comply with this standard and are located in the use zone must also comply with ASTM F 1292. The test methods in this standard address access for children and adults who may traverse the surfacing to aid children who are playing. When a surface is tested it must have an average work per foot value for straight propulsion and for turning less

than the average work per foot values for straight propulsion and for turning, respectively, on a hard, smooth surface with a grade of 7% (1:14).

III. Americans with Disabilities Act - Department of Transportation Regulations

a. Department of Transportation regulations elucidate specific requirements under the ADA for public and private transportation systems.

i. Fixed Route Buses

1. to operate fixed route buses with wheelchair lifts and other accessibility features, to maintain the wheelchair lifts and other accessibility features on its buses in operative condition; maintain accessibility of its bus stops, including mechanical defects and snow removal, promptly repair wheelchair lifts and other accessibility features if they are damaged or out of order; establish a system of regular and frequent maintenance checks of wheelchair lifts; remove a vehicle from service if the lift is inoperative (with limited exceptions); provide alternative transportation when the lift doesn't work and the next accessible bus is more than 30 minutes away; train personnel so that they properly assist and treat individuals with disabilities in a respectful and courteous way and operate equipment safely; use securement systems to secure wheelchairs on the bus; designate a responsible employee to coordinate its efforts regarding accessibility; and adopt complaint procedures. SAM must also provide Paratransit or other special service to individuals with disabilities that is comparable to the level of service provided to individuals without disabilities who use the fixed route system.²

ii. Paratransit (49 C.F.R. § 37)

1. DOT ADA regulations require Paratransit service to be operated without capacity constraints (49 C.F.R. § 37.131(f)).

² 49. C.F.R. § 37.121.

2. Sections 37.123 through 37.127 of the DOT ADA regulations require that a process be established for determining who is ADA Paratransit-eligible and that determinations of eligibility be made consistent with regulatory criteria.
3. Section 37.129(a) requires that ADA complementary Paratransit be origin-to-destination service.
4. Section 37.131(a) requires ADA complementary Paratransit service be provided in all geographic areas where non-commuter fixed route service is provided.
5. Section 37.131(b) requires that “next-day” service be provided. Section 37.131(c) requires that ADA complementary Paratransit fares be no more than twice the full fixed route fare.
6. Section 37.131(d) requires that ADA complementary Paratransit service be provided without restrictions or priorities placed on trip purpose.
7. Section 37.131(e) requires that ADA complementary Paratransit service be provided during all days and hours that fixed route service is provided.
8. Section 37.131(f) requires Paratransit service to be operated without capacity constraints
9. Section 37.139(g) requires that plans for ADA complementary Paratransit service address efforts to coordinate with other public entities that have contiguous or overlapping ADA complementary Paratransit service areas.

Specific Requirements

- **Sidewalks**: The public right-of-way consists of everything between right-of-way limits, including travel lanes, medians, planting strips, sidewalks, and other facilities.³
- The DOJ regulations designate the Department of Transportation as the agency responsible for overseeing public agencies' compliance with the ADA. 28 C.F.R.

³ See http://www.fhwa.dot.gov/civilrights/programs/ada_sect504qa.htm#q9

§35.190(b)(8). The DOT has delegated to the Federal Highway Administration the responsibility to ensure ADA compliance in the public right-of-way and on projects using surface transportation funds.

- FHWA is responsible for ensuring access for persons with disabilities in four areas:
 - For surface transportation projects under direct FHWA control (e.g., Federal Lands projects): FHWA is responsible for ensuring that project planning, design, construction, and operations adequately address pedestrian access for people who have disabilities.
 - For Federally funded surface transportation projects that provide pedestrian facilities within the public right-of-way: FHWA is responsible for ensuring that the public agencies' project planning, design, and construction programs provide pedestrian access for persons with disabilities. FHWA-funded projects outside of the public right-of-way, such as Transportation Enhancement projects, must also adhere to these requirements.
 - For pedestrian facilities within the public right-of-way, or any other FHWA enhancement project, regardless of funding source: FHWA is responsible for investigating complaints. 28 C.F.R. §§ 35.170 – 35.190.
 - FHWA should provide or encourage accessibility training for Federal, State, and local agencies and their contractors.
 - FHWA does not have ADA oversight responsibilities for projects outside of the public right-of-way that do not use Federal surface transportation program funds. However, ADA title II requirements generally still apply even if only state or local funds are used, particularly for new construction. ⁴

⁴ 42 U.S.C. §12131(1).

Appendix 2: Documents Reviewed (Illustrative)

The City ADA Coordinator's Office compiles and maintains a listing of documents produced (and meetings held) for purposes of this review. Among them:

- Transition Plans
 - 1998 ADA Study
 - 2001 ADA Transition Plan
 - 2002 ADA Transition Plan
 - 2003 ADA Transition Plan
 - 2015 Draft ADA Transition Plan
 - 2018 Public Rights of Way Transition Plan
- Sioux Falls Transit Development Plan, 2011-2015
- Sioux Falls Accessibility Review Board Minutes
- 2011 Bus stop reviews
- Bus Shelter inspection template
- SAM Paratransit riders guide
- Sioux Falls MPO Area Coordinated Public Transit Human Services Transportation Plan
- Bus Shelter inspection template
- On time performance
- Bus stop details for snow removal-Presentation
- Trip disposition summary - Paratransit-3943_001
- PLANNING ADA Audit
- SAM ADA Audit
- H680021_para_needs_assessment_doc
- H680022_Paratransit_riders_guide_r060810
- Paratransit service areas
- City of Sioux Falls Sidewalk Policies
- 2006_pedestrian_plan_040606
- CUR B-RAMPS-OVERLAY-10-11
- Monthly Driver Training Agenda, January, 2011
- Driver bus stop inspection sheets
- 2017 Parks Department Transition Plan

Appendix 3: On Time Performance Data

SIOUX AREA METRO SIOUX FALLS, SOUTH DAKOTA													
On-time performance													
2011	JAN	FEB	MAR	APR	MAY	JUN	JUL	AUG	SEP	OCT	NOV	DEC	Average
Fixed route	96%	94%	94%	95%	95%	96%	96%	98%					96%
Paratransit	93%	93%	95%	93%	98%	97%	100%	98%					96%
2010	JAN	FEB	MAR	APR	MAY	JUN	JUL	AUG	SEP	OCT	NOV	DEC	
Fixed route	98%	98%	98%	98%	98%	98%	98%	96%	95%	94%	91%	86%	96%
Paratransit	98%	98%	88%	88%	95%	88%	90%	92%	91%	92%	91%	91%	92%

Appendix 4: Monthly bus driver training minutes

SIOUX AREA METRO

AGENDA FOR JANUARY, 2011

SAFETY MEETINGS

Safety Message – **(Dennis)**

Accident Log updates **(Randy)**

Review number of incidents involving damage to 4 vehicles including #9724 (top right rear corner), #914 (right rear wheel), #1072 (driver's step) and #1065 (lower right panel in front of rear wheel well) **(Randy)**

Review pre-trip inspection and DVI procedures. Thoroughly check your bus for any issues that may need immediate attention or repair. Any items printed in bold print on the DVI are safety issues and must be repaired before leaving the garage. Look for existing damage and notify a supervisor of any damage not recorded in the binder. Adjust your mirrors. **Hand out procedures/guidelines for adjusting exterior mirrors.** (Randy)

Discuss the videos on You Tube involving the snowman hit by bus driver and lap dance for bus driver – As tempting as it may be, do not go out of your way or ignore the safety rules of the road and your job just to have a little fun. It could cost you your job or worse, you could injure someone. Also, a passenger may be recording your actions! **(Randy)**

Drivers: look for safe areas at bus stops to board and exit passengers from the bus. Do not stop your bus where passengers have to climb over a windrow of snow to board or exit the bus. Stop your bus at the nearest safe location to the bus stop or stay 3-4 feet from the curb if it is safe. Warn passengers of any ice or snow etc. At times, due to the snow along the curb, you may need to open the front door only and request the exiting passengers to use the front door. (Randy)

Buckle Guards – Buckle guards are available in the paratransit dispatch office. The buckle guards fit on all seatbelts in all of the buses. Ford Concord and Chevy Glaval buses: the guard must be put on the belt before buckling the belt. On Ford Goshen buses, the guard must be put on after you fasten the buckle. Pictures are posted on the Paratransit board. If you need additional training or questions, please see Tierza. (Randy)

Watch for Fixed Route passenger: David Ortiz. He has been suspended from riding the bus. If and when he returns after his suspension, drivers need to watch for this passenger and if he is “hanging out” inform him that he either needs to catch a bus or leave the premises. Notify a

supervisor of any suspicious activity with this passenger (i.e. constantly watching high school girls, etc.) Write up an Incident Report. **(Randy)**

Smoking at the Bus Stop – Get driver’s thoughts and ideas on a designated area at the Bus Stop where passengers and employees would be required to go to smoke. Thoughts on the north end of TBS? **(Karen/Randy)**

Encourage SAM employees to become ambassadors of the transit system. Looking for committee/volunteers to come up with ideas. (Discussed at the Marketing Committee meeting) **(Karen/Randy)**

Supervisors and drivers can authorize emergency transfers to passengers who miss their bus because of our fault (certain situations). Also regular passengers who ride everyday but forgot their pass may be given an emergency transfer in certain situations. **(Dennis)**

Drivers need to leave the garage on time at the beginning of their shift. Be on time when arriving at the TBS and also paratransit driver’s should leave the garage on time. After checking in, paratransit drivers need to stop into the paratransit dispatch office for possible changes to their manifest. **(Dennis)**

Drivers need to notify supervisors of bus stops that need to be cleared. This includes shelters, benches and bus stops that need special attention (serving passengers with disabilities, etc. (Dennis)

Ridership, complaints, etc. information **(Dennis)**

Distribute Perfect attendance Awards (Dennis/Karen/Randy)

Appendix 5: Ramps Installed – Overlays and Reconstructions

Appendix 6: Sioux Falls 2017 Updated Parks Department Transition Plan and Selected Documents

7.2.1 - ADA Existing Facility and Site Access Audit

Standard: *The agency shall complete an access audit of all existing sites and facilities. Pursuant to the US Department of Justice Title II regulation at 35.105, the agency must evaluate its existing facilities and sites against the most current final and enforceable Standard for Accessible Design.*

Suggested Evidence of Compliance: Submit completed checklists, digital images and site reports as evidence of completion of the access audit.

[Informational reference in the *Management of Park and Recreation Agencies*, \(2010\), 3rd Ed., Chapter 11 – Physical Resource Planning, pp. 226 and 236; Chapter 12 – Physical Resource Management, pp. 253 and 263; Chapter 13 – Management Operations, p. 288.](#)

Agency Evidence of Compliance:

The team consisting of LCM Architects, the City of Sioux Falls, and local consultants developed the City’s transition plan in 2001 as required by Title II 28 CFR part 35.150(c) of the Americans with Disabilities Act (ADA). The transition plan consisted of recommendations for structural corrective actions for the City in order to provide access to the public programs and services conducted at or within various sites and facilities. The recommendations were put into detailed reports for each of the sites and facilities. The majority of the plan’s recommendations were completed as part of dedicated ADA retrofit projects from 2002 to 2008, through projects in our cyclic maintenance programs from 2002 to present, and part of large park renovation projects.

The City ADA Coordinator and City Park Development Specialists conducted a series of site inspections in summer 2016 to review the status of the original transition plan for the department and to identify additional barriers at these sites and facilities per the updated ADA standards. The resulting report is intended to serve as the department’s updated transition plan.

The 2017 Updated ADA Transition Plan was approved by the ADA Accessibility Review Board on July 25, 2017. The updated transition plan worksheet provides a summary of the department’s plan to address outstanding recommendations from the original plan and the additional recommendations identified during the site inspections performed in 2016. The detailed reports showing identified deficiencies at each park location were updated to show the status of the corrections. The department’s current 5-year capital plan includes a dedicated ADA retrofit project in 2019, playground replacement projects in the cyclic maintenance program, and larger renovation projects at other parks to remove all the barriers identified in the updated transition plan. The specific project years and budgets are listed on the updated transition plan worksheet.

Documentation Provided:

- A. 2017 Updated ADA Transition Plan Summary

- B. 2017 Updated ADA Transition Plan
- C. Detailed Report- Bryant Park
- D. ADA Accessibility Review Board Minutes- July 25- 2017
- E. Capital Program 2019 – 2023- p. 114- ADA Transition Plan Improvements

Agency Self-Review: Met Not Met

Visitor Comments:

Visitor Evaluation: Met Not Met

City of Sioux Falls

ADA Title II Transition Plan Update- 2017

Report Overview

The team consisting of LCM Architects, the City of Sioux Falls (the City), and local consultants developed the City's transition plan in 2001 as required by Title II 28 CFR part 35.150(c) of the Americans with Disabilities Act(ADA). The transition plan consisted of recommendations for structural corrective actions for the City in order to provide access to the public programs and services conducted at or within various sites and facilities. The recommendations were put into detailed reports for each of the sites and facilities and the corrective actions were either budgeted in the City's 5-year capital program or incorporated into future, large renovation projects.

Colleen Moran(City ADA Coordinator), Tory Miedema and Mike Patten(City Park Development Specialists) conducted a series of site inspections in summer 2016 to review the status of the original transition plan for the City's Parks and Recreation Department(the department) and to identify additional barriers at these sites and facilities per the updated ADA standards. The resulting report is intended to serve as the department's updated transition plan.

In addition to the updated transition plan, it is the department's policy to review all new park construction and large renovation projects with the City's ADA Advisory Board and bring these sites and facilities into full compliance with the current ADA guidelines.

Status of Original Plan

During the site inspections performed in 2016, all the recommendations contained in the original transition plan's detailed reports were checked to determine their status. The status of each recommendation was documented and can be found in the detailed reports.

The department has made great strides in providing accessibility to the programs and services conducted at the various sites and facilities in the park system, completing a majority of the recommendations set forth in the transition plan. The department completed numerous projects through the capital program to remove the accessibility barriers, as described in further detail below.

The department's capital program included a dedicated ADA retrofit project from 2002 to 2008 to correct specific barriers identified in the transition plan at parks and facilities where larger renovation projects were not planned in the near future. The department spent nearly \$1.5M in this time frame addressing the recommendations deemed highest priority. The projects included ADA improvements to 46 different parks and facilities in the system.

The transition plan's recommendations were also addressed through the department's cyclic maintenance programs. The cyclic programs address the renovation or replacement of the following amenities in the park system:

- Play courts(basketball/tennis)- 18 locations
- Playgrounds- 29 locations
- Picnic shelters- 10 locations

- Parking lots- 28 locations

The department has completed multiple projects in these programs yearly from 2002 to present, spending an average of \$750,000 yearly. In addition to bringing the specific play courts, playgrounds, picnic shelters, and parking lots into compliance, these projects also addressed identified barriers related to or adjacent to the specific amenity. The additional barriers addressed as part of these projects include accessible pathways, signage, picnic tables, benches, etc.

The department has completed a number of large renovation projects since 2002 that have addressed identified barriers and brought the entire park or facility into compliance with the most current ADA requirements at the time. Some of the more notable projects include:

- Pioneer Park spray park and restroom(2006- \$700,000)
- Dugan Park renovation(2006- \$219,000)
- Sherman Park ball field renovations(2006- 2011- \$3,200,000)
- Nelson Park/Drake Springs Pool replacement(2008- \$4,200,000)
- McKennan Park renovations(2008- 2009- \$936,000)
- Jefferson Park renovation(2009- \$207,000)
- Spellerberg Park renovation/Pool replacement(2016- \$24,000,000)

The department has also completed large renovation projects that have brought parks into compliance that were listed as “relocate activities” parks in the original transition plan. These projects include:

- Meldrum Park renovation(2012- \$150,000)
- Lyon Park renovation(2014- \$353,000)
- Bryant Park renovation(2015- \$145,000)

Updated Transition Plan

The updated transition plan worksheet provides a summary of the department’s plan to address outstanding recommendations from the original plan and the additional recommendations identified during the site inspections performed in 2016. The department’s current 5-year capital plan includes a dedicated ADA retrofit project in 2019, playground replacement projects in the cyclic maintenance program, and larger renovation projects at other parks to remove all the barriers identified in the updated transition plan. The specific project years and budgets are listed on the updated transition plan worksheet.

The updated transition plan also includes a list of parks and/or facilities where no recommendations for barrier removal has been made due to the proximity of these facilities to other parks which offer similar facilities and programs. These parks and/or facilities have been labeled as “relocate activities” parks/facilities in the updated plan. While no recommendations have been made to remove these barriers, it is the department’s policy to review any large renovation projects with the City’s ADA Advisory Board and bring these sites and facilities into full compliance with the current ADA guidelines.

Appendix 6 (A): 2002 ADA Transition Plan- updated 2017.pdf

Appendix 6 (B): ADA- 2019 project scope.pdf

Appendix 6 (C): ADA Accessibility Review Board Minutes- July 25- 2017

Appendix 6 (D): Capital Program 2019 – 2023- p. 114- ADA Transition Plan Improvements

Appendix 7: City of Sioux Falls Parks Department ADA Related Policies



**CITY INTEROFFICE
MEMORANDUM**

Date: November 1, 2003

To: Dave Fischer

From: Jeff Munce

Subject: Parks ADA Standard Operating Procedures

The standard operating procedures (SOP) below address several questions which were posed during the ADA Transition Plan process. These SOPs may change as accessible standards change. These SOPs do not include all requirements for accessible features in a park setting.

1. Accessible Grills

Many parks have pedestal grills which were installed prior to 1990. These grills are typically located in a grassy area and not on an accessible route. These grills do not have hard surfacing below them for wheelchair access. At this time, it has been decided that these grills will be removed when they are due for replacement. If grills are replaced or added to current or future parks, these grills must meet ADAAG 16.7 COOKING SURFACE, GRILLS, PEDESTAL GRILLS.

2. Accessible Benches

As existing benches are replaced, benches will be purchased and provided on an accessible route until 50% of the benches in each park are compliant. Non-fixed benches and fixed benches will be included in the total count when determining the number of accessible benches. New parks will be built according to the 50% rule below.

Where fixed benches are provided in a park, 50% shall be on an accessible route. Of these fixed benches, 50% shall also comply with 16.12.8 (armrests). *See generally*, ADAAG 16.12.2.2. Of those required to include armrests, at least one armrest shall be provided on the bench and shall comply with ADAAG 4.26.3 (structural strength). *See generally*, ADAAG 16.12.8.

When planning a fixed bench location, there should also be a hard surfaced pad (concrete, rolled asphalt, etc.) under the bench, which is connected to the accessible route. The pad size that has been used is 6'x9'; this will depend on the bench size. The long side of the pad runs along the back of the bench, with the edge directly below the bench back. There must be at least 30"x48"-36"x48" (minimum 30", recommended 36") beside the bench. This allows a person sitting on the bench to sit next to a person in a wheelchair, shoulder to shoulder. See, ADAAG 4.37.2.

Benches must be fixed and have seats that are 20" to 24" in depth and 42 " minimum in length. The front edge of the seat shall have a height between 17" to 19" above the ground. See, ADAAG 4.37.3.

For a bench to be considered "fixed," it must be strong enough to withstand a vertical or horizontal force of 250 pounds applied at any point on the seat, fastener, mounting device, or supporting structure. A bench that is not "fixed" is not considered accessible. Existing concrete benches will be considered "fixed."

Where non-fixed benches are provided in a "specialized-use" area (i.e. band shells, formal flower gardens, warming houses, etc.), at least 5%, but not less than one, shall be accessible. Accessible benches in a "specialized-use" area shall be signed with the universal symbol of accessibility.

3. Accessible Picnic Tables

Where non-fixed picnic tables are provided in a picnic area, at least 5%, but not less than one, shall be accessible. Typically, a neighborhood park will have one non-fixed accessible table in or around a single shelter; a regional park will have two non-fixed accessible tables in or around a single shelter. Accessible tables will be fixed where practical.

Where two or more fixed picnic tables are provided in a picnic area, at least 50%, but not less than two, shall be accessible. Of the fixed picnic tables required to be accessible, 40%, but never less than two, shall be located along an outdoor recreation access route. For example, if ten fixed tables are provided in a picnic area, this provision would require five tables to be accessible. In addition, of the five required to be accessible, 40%, or two, would need to be located along an outdoor recreation access route. See, section 16.5.1.2.

A 36-inch minimum clear space surrounding the usable portions of a table is required, measured from the outside edge of the seat, or the outside edge of the table if no seat is provided. See, section 16.5.5. Tables placed in buildings are generally expected to have ample space for moving around. This is not always the case where picnic tables are located in the outdoor environment. Provide maneuvering room beyond the accessible seating space to all usable portions of the table to allow for movement around the table.

Accessible tables shall be dispersed among the various types of picnic settings or opportunities provided. For example, a particular picnic area may offer picnic sites near the lake, in the

woods, and in the open, sunny portion of the area. This provision requires that the number of accessible tables be distributed throughout the area, so that people with disabilities would have a choice of picnic locations similar to what other visitors to the area have. This section would not increase the total number of accessible tables. See, section 16.5.1.2.

At least one wheelchair seating space shall be provided at an accessible picnic table with a table top perimeter not exceeding 24 linear feet (average table dimensioned at ten-foot long by 2-1/2 foot wide; this table has a perimeter of 25 linear feet and is designed to accommodate up to ten people). More accessible seating spaces would be required where the perimeter of the table top (not including the bench) exceeded 24 linear feet. The location of the accessible seating space(s) would be left to the discretion of the designer, although it is recommended that the accessible spaces be dispersed rather than clustered in one location. See, section 16.5.3.

Each accessible seating space will provide knee space of at least 30 inches wide, 19 inches deep, and 27 inches from ground/floor to the bottom of the table top. A toe clearance of 9 inches above the ground/floor extending for a total depth of 24 inches is also required. See, section 16.5.4.

4. Pools

- a. McKennan wading pool- Will defer renovation until major project is done as per aquatic study. If request is made to accommodate a disabled person, we will allow free admittance to Laurel Oak or Terrace pools.
- b. Pools in General- Defer construction until major renovation is completed as per aquatic study, except for those which have restrooms that serve the whole park, which will be addressed in the transition plan or during planned construction, whichever occurs first.

5. Sales and Service Counters and Desks

Service Counter height- 36" from floor to workable surface.

Service Counter width- minimum of 36". It is recommended to use a universal design approach which suggest this section be wider or the entire length of this side of the counter, thereby not drawing attention to this area as the ADA portion of the counter.

Desk- The desk must provide 27" knee clearance, provide 30" width under the desk and be at least 19" deep. The top of the desk can be from 28" to 34" above the finished floor.

Protruding objects- Often counters hang over the wall or cabinet they are attached to. Objects mounted above 80" or at or below 27" can protrude in any amount. This means the counter can only protrude 4" into the walking path, if it is higher than 27" or below 80".

6. Sand Volleyball Courts

Provide accessible route to spectator area of 50% of the courts at Cherry Rock, Riverdale, and any future sites with more than one court, which are programmed for organized play.

7. Playground Structures

All new and existing playground structures will be accessible, except those in parks where activities are to be relocated, pursuant to the transition plan, and where technically infeasible (Meldrum).

8. On-Street Parking

In order to promote better accessibility within the City street right-of-way, the following procedures will address on-street parking along residential neighborhood parks.

Requests will be forwarded to the City ADA Coordinator, then the City ADA Coordinator will forward the request to the City Engineering Office. All requests will be addressed as follows:

- a. Written citizen requests establish need and will be based on a case-by-case basis.
- b. The accessible parking space will be placed in the closest proximity to a curb ramp, typically at the beginning or end of each street block. Whenever possible, an accessible parking space will not be placed adjacent to a residential property owner; if necessary, that landowner will be contacted prior to placement for input.
- c. If accessible on-street parking is placed next to a curb ramp or driveway approach, no sidewalk extension will be required.
- d. If no curb ramp or driveway approach is available, then a sidewalk extension will be required by the Parks and Recreation Department prior to placement of the accessible parking signage.
- e. If a curb ramp is required by the requesting citizen, no sidewalk curb ramp will be placed mid-block. It is recommended that access to the sidewalk be provided through street intersection curb ramps and driveway approaches. If curb ramps are not already placed at the intersections at head and foot of block of which the citizen is requesting accessible parking, these will be scheduled for placement.
- f. Accessible parking signage will consist of two accessible parking signs, with supplementary signs indicating the beginning and ending of the parking space with arrows. The signs will be placed 25 feet apart. All on-street parking signage will be placed by the Public Works Department.

9. Accessible Routes

In accessibility guidelines, three accessible route definitions exist depending on the type of access route. Each has its own requirements:

1. "Accessible Routes" are ground and floor surfaces for accessible rooms and spaces including floors, walks, ramps, stairs, and curb ramps, which shall be stable, firm, and slip-resistant. ADAAG 4.5.1.
2. "Pedestrian Access Route" is a key term that refers to the portion of the public right-of-way that serves as an accessible route. (Public Right-of-Way Design Guide definitions).
3. "Accessible Trails/Outdoor Recreation Access Routes" include newly constructed and altered trails that meet all of the provisions of ADAAG 16.2. Departures from certain technical provisions are permitted pursuant to ADAAG 16.2. Furthermore, those trails that meet the provisions are required to be signed, indicating that they are accessible.

In the parks system, the standard minimum clear width of an access route is 60", except at doorways. When this width is reduced to less than 60", it may not be reduced to less than 36" for an "accessible route" or "accessible trail," or no less than 48" for a "pedestrian access route." Specific exceptions exist for routes narrower than 60", therefore contact the City ADA Coordinator when designing a narrower route.

For an "accessible route" or "pedestrian access route," the *running slope* of walking surfaces shall not be steeper than 1:20 (5%). The *cross slope* of walking surfaces shall not be steeper than 1:48 (2%). See, ADAAG 403.3. Exceptions exist for running and cross slopes for "accessible trails." Consult the City ADA Coordinator when designing an "accessible trail," which may require an exception to the slope.

At least one accessible route shall connect accessible buildings, facilities, elements, and spaces that are on the same site. See, ADAAG 4.3.2 (2).

Changes in level of 1/4" high maximum shall be permitted to be vertical. Changes in level between 1/4" high minimum and 1/2" high maximum shall be beveled with a slope not steeper than 1:2. Changes in level greater than 1/2 inch (13 mm) high shall be ramped. See ADAAG 303.1-303.3. All ramp requirements shall apply.

Headroom and protruding objects. Walks, halls, corridors, passageways, aisles, or other circulation spaces shall have 80" minimum clear head room. If vertical clearance of an area adjoining an accessible route is reduced to less than 80", a barrier to warn blind or visually-impaired persons shall be provided. See, ADAAG 4.4.2. Objects projecting from walls (for example, telephones) with their leading edges between 27" and 80" above the finished floor shall protrude no more than 4" into walks, halls, corridors, passageways, or aisles. Objects mounted with their leading edges at or below 27" above the finished floor may protrude any amount. Free-standing objects mounted on posts or pylons may overhang 12" maximum from 27" to 80" above the ground or finished floor (i.e., post-mounted drinking fountains). Protruding objects shall not reduce the clear width of an accessible route or maneuvering space. See, ADAAG 4.4.1.

Accessible trail signage. ADAAG 6.2.10 requires signs on newly constructed and altered trails and trail segments that comply with all the technical provisions of 16.2 to be designated with a symbol at the trail head or designated access points. Trail Head signs identifying accessible trail segments shall include the total length of the accessible trail segment. In addition, a symbol on the sign shall identify those trails that are accessible. On a trail segment sign, a symbol is used to identify accessible trail segments, the total length of the accessible trail segment must be provided.

10. Restrooms

a. Brick and Mortar

New restrooms will be built accessible. For existing restrooms near the end of their useful life, a determination will be made on a case-by-case basis as to feasibility of major renovation prior to replacement of the structure. Portable accessible restrooms will be added next to inaccessible brick and mortar restrooms upon citizen request.

b. Portable- Where multiple single user portable toilets are clustered at a single location, at least 5%, but not less than one toilet unit or bathing unit at each cluster shall be provided. *Accessible* units shall be identified by the International Symbol of Accessibility. See, ADAAG 213.2.

A standard portable toilet may be provided in neighborhood parks during the summer months, unless a request is made to provide the park with an accessible portable toilet in the alternative. If a request is made, an accessible portable toilet shall be provided pursuant to ADAAG 213.2.

Portable toilet units provided for use exclusively by construction personnel on a construction *site* are not required to be *accessible*.

11. Facility Matrix

A facility matrix will be developed and include all parks and their accessible features. It will be made available on the website, at the park administration office, and at the park headquarters.

12. Trash Receptacles along accessible route

At least 50% of all trash and recycling containers in a park will be accessible. For a trash or recycling container to be considered accessible, it must be placed on an accessible route, it must be fixed, and it must have a clear space slope around the trash receptacle of no greater than 1:50, which allows a forward or a parallel approach by a person using a wheelchair. An exception permits a 1:33 slope for proper drainage. See, ADAAG 16.8.4.

When providing 50% of all trash and recycling containers as accessible is not practical, an exception, exists, as long as program access is maintained. To maintain program access, each

park feature (i.e. formal garden, restroom, shelter, play structure, play field or court, etc.) that is along an accessible route, shall have a minimum of one accessible trash receptacle.

13. Playing Fields and Courts

Existing playing fields and courts will be addressed according to the 2002 ADA Transition Plan. According to the transition plan, 50% of each type of playing field and court at each accessible park will be served by an accessible route and an accessible viewing area. At parks where greater than 50% of the fields could easily be made accessible, the greater percentage is recommended.

Where new playing fields and courts are being developed, each field and court will be made accessible. This would include an accessible route to the spectator area, an accessible seating area and an accessible route to any fixed player seating.

14. Drinking Fountains

If drinking fountains are provided, at least 50% shall be accessible (double bowl) according to ADAAG 4.15 and shall be on an accessible route. If only one drinking fountain is provided in a park or section of a larger park, it shall comply with ADAAG 4.15. ADAAG 4.1.2(9). For example, if a drinking fountain is provided in upper Terrace and a drinking fountain is provided in lower Terrace, both must be accessible. Drinking fountains with two spouts (or bowls) assist both people in a wheelchair and those people who find it difficult to bend over. See ADAAG Appendix A4.15.2. **Lower** spouts shall be no higher than 36", measured from the floor or ground surfaces to the spout outlet. See ADAAG 4.15.2. Upper spouts shall be 39" minimum and 43" maximum above the floor or ground. See ADAAG 602.7.

Wall- and post-mounted cantilevered units shall have a clear knee space between the bottom of the apron and the floor or ground at least 27" high, 30" wide, and 17" to 19" deep. Such units shall also have a minimum clear floor space 30" by 48" to allow a person in a wheelchair to approach the unit facing forward.

Free standing or built-in units not having a clear space under them shall have a clear floor space at least 30" by 48" that allows a person in a wheelchair to make a parallel approach to the unit. This clear floor space shall comply with ADAAG 4.2.4.

City of Sioux Falls Parks and Recreation Policies and Guidelines, 2020, Attachment 10: Sioux Falls Parks and Recreation's Policy on Other Power-Driven Mobility Devices (OPDMDs)

Updated February 21, 2017

INTRODUCTION

On March 15, 2011, the Department of Justice (DOJ) revised rules allowing Other Power-Driven Mobility Devices (OPDMD) to be used by individuals with mobility disabilities. Under the American with Disabilities Act (ADA) Title II, this DOJ rule applies to trails on state or local government lands. The amended law states, "A public entity shall make reasonable modifications in its policies, practices, or procedures to permit the use of other power-driven mobility devices by individuals with mobility disabilities, unless the public entity can demonstrate that the class of other power-driven mobility devices cannot be operated in accordance with legitimate safety requirements that the public entity has adopted pursuant to § 35.130(h)."

Sioux Falls Parks and Recreation has completed an assessment of all trails within the system to determine any limitations on OPDMDs, identify the areas where they are permitted, describe the characteristics of allowed devices, and establish rules for safe use.

Definitions:

Motorized wheelchairs or mobility scooters means manually-operated or power-driven devices designed primarily for use by an individual with a mobility disability for the main purpose of indoor or of both indoor and outdoor locomotion. (Americans with Disabilities Act §35.104)

Other power-driven mobility device (OPDMD) means any mobility device powered by batteries, fuel, or other engines—whether or not designed primarily for use by an individual with mobility disabilities—that is used by individuals with mobility disabilities for the purpose of locomotion, including golf cars, electronic personal assistance mobility devices (EPAMDs), such as the Segway® PT, or any mobility device designed to operate in areas without defined pedestrian routes, but that is not a wheelchair within the meaning of this section. (Americans with Disabilities Act §35.104 and §36.104.)

Disability means, with respect to an individual, a physical or mental impairment that substantially limits one or more of the major life activities of such individual; a record of such an impairment; or being regarded as having such an impairment. The phrase major life activities means functions such as caring for one's self, performing manual tasks, walking, seeing, hearing, speaking, breathing, learning, and working. (Americans with Disabilities Act §35.104.)

Assessment Factors:

In accordance with the DOJ, the following assessment factors have been used to determine whether a particular OPDMD can be allowed within a specific facility as a reasonable accommodation:

- (i) size, weight, dimensions, and speed of the device.
- (ii) the facility's volume of pedestrian traffic.
- (iii) the facility's design and operational characteristics.
- (iv) whether legitimate safety requirements can be established to permit the safe operation of the OPDMD at the facility.
- (iv) the potential for serious harm to environmental, natural, and cultural resources.

Inquiry into use of OPDMD:

Sioux Falls Parks and Recreation reserves the right to ask a person using an OPDMD to provide credible assurance that the mobility device is required because of disability. Credible assurance includes a valid, state-issued disability parking placard or card, or other state-issued proof of disability. In lieu of these items, Sioux Falls Parks and Recreation shall accept as a credible assurance a verbal representation, not contradicted by observable fact, that the OPDMD is being used for a mobility disability.

Inquiry about disability: Sioux Falls Parks and Recreation will not ask an individual using a wheelchair or other power-driven mobility device questions about the nature and extent of the individual's disability.

SIoux FALLS PARKS AND RECREATION'S OPERATIONAL POLICY ON OTHER POWER-DRIVEN MOBILITY DEVICES

I. GENERAL GUIDELINES:

- A. Operators of all mobility devices must adhere to Sioux Falls Parks and Recreation's ordinances for their safety, the safety of other park users, and for the protection and preservation of the property, facilities, and natural resources of Sioux Falls Parks and Recreation.
- B. Mobility devices must be electric powered only. The exclusion of gas-powered devices as compared to electric-powered devices is due to these factors:
 - o The noise of gas-powered devices produces a significant zone of disturbance to the activities of native wildlife.
 - o The noise and excessive fumes of gas-powered devices negatively impact the experience of other park visitors.
 - o Gas emissions from small engines emit high levels of carbon monoxide, a colorless, odorless, poisonous gas, which is known to negatively affect human and plant health.

- C. Mobility devices are not permitted on trail segments that are closed or designated for “authorized personnel.”
- D. Sioux Falls Parks and Recreation reserves the right to suspend use of trail segments by the operator if doing so is in the best interests of the department.
- E. Sioux Falls Parks and Recreation reserves the right to change, modify, or amend this policy at any time.

II. MOTORIZED WHEELCHAIRS OR MOBILITY SCOOTERS

Wheelchairs and mobility scooters can be used in areas open to pedestrians, which would include trails (Americans with Disabilities Act 35.104 and 36.104). Special use passes are not required for these devices. Trails may have irregular tread widths and may not include trail shoulders. There could be trees or other natural obstacles close to the trail corridor, and trails could be eroded or muddy. There may be obstructions or bridges that make traversing with a wheelchair or mobility scooter more challenging or impassable at times.

III. OTHER POWER-DRIVEN MOBILITY DEVICES

Effective January 1, 2014, Sioux Falls Parks and Recreation will allow appropriate OPDMDs on trails to assist persons with mobility disabilities to more fully enjoy the trail experience. In order to provide credible assurance of their need for an OPDMD, users are expected to display or carry a state-issued disability parking placard or card.

Park Trail Assessments and Restrictions:

Park trails can be categorized into three classes with specific limitations and justifications as listed below:

Class I

- Trail surface is paved with asphalt or concrete and has grades of 0–5 percent and minimal side slopes.
- Trails accommodate two-way traffic and are generally 8 to 10 feet wide.
- Trails are designed and intended for multiple uses by pedestrians, bicycles, and other nonmotorized devices such as rollerblades.
- Trail use can be heavy depending on location, day of the week, and time of day.

DOJ Assessment Factors:

- (i) size, weight, dimensions, and speed of the device.
- (ii) the facility’s volume of pedestrian traffic.
- (iii) the facility’s design and operational characteristics.

OPDMDs Allowed/Restrictions:

- No wider than 32 inches to allow for safe passing of other OPDMDs, bicycles, dogs on leash, and pedestrians.
- Length restriction: Must allow for safe passing and turning on trails.
- Speed—In no case can an OPDMD be operated greater than the speed of pedestrian traffic.

Class I Trails

ID #	Park	Description	Distance Miles
1	Bike Trail	Falls Park Drive to Cliff Avenue (Nelson Park)	1.70
2	Bike Trail	Cliff Avenue to 26th Street (Rotary Park)	1.39
3	Bike Trail	26th Street to Cliff Avenue (Tuthill Park)	1.73
4	Bike Trail	Cliff Avenue to Western Avenue (Yankton Trail)	2.27
5	Bike Trail	Western Avenue to 41st Street	1.38
6	Bike Trail	41st Street to 12th Street (Sherman Park)	2.15
7	Bike Trail	12th Street to Russell Street (Elmwood Park)	1.64
8	Bike Trail	Russell Street to Minnesota Avenue	3.77
9	Bike Trail	Minnesota Avenue to North Drive	2.02
10	Bike Trail	North Drive to Falls Park Drive	0.99
11	Bike Trail	Fawick Park to Cherry Rock Park	1.15

Appendix 7: Parks ADA Related Policies

12	Bike Trail	Riverdale Park to Rotary Park	0.14
13	Bike Trail	Pasley Park to 49th Street (Southeastern Avenue)	1.34
14	Bike Trail	Spencer Park to Tomar Park	0.22
15	Bike Trail	57th Street to Sertoma Park	0.78
16	Bike Trail	49th Street to Kiwanis Avenue (Oxbow Park)	0.43
17	Bike Trail	49th Street to 41st Street (west side)	0.59
18	Bike Trail	I-29 to Marion Road	0.62
19	Bike Trail	Marion Road to Dunham Park	0.49
20	Bike Trail	Dunham Park to Legacy Park	1.12
21	Bike Trail	Sherman Park/Great Plains Zoo access trail	0.28
22	Bike Trail	Falls Park to Lien Park	0.59
23	Family	East parking lot to fishing dock	0.11
24	Family	West parking lot to fishing dock	0.03
25	SD 100	From 57th Street to 41st Street	0.99
26	SD 100	From 41st Street to 33rd Street	0.48
27	SD 100	From 33rd Street to 26th Street	0.49
28	SD 100	From 26th Street to 23rd Street	0.19
29	SD 100	From 23rd Street to Split Rock Road	0.28
30	SD 100	Split Rock Road to dead end at Arrowhead Parkway	0.36
31	SD 100	Madison Street to Maple Street	1.18
32	Bike Trail/Lien Park Spur	Cliff Avenue to dead end	.71
33	Diamond Creek	57th Street to Western Avenue	.52

34	Elmwood	Elmwood Park trail access point	0.1
35	Bike Trail	Marion Road to Skunk Creek diversion dam	1.25

Class II

- Trail surface is compacted recycled asphalt or compacted aggregate with grades of 0–5 percent and minimal cross slopes.
- Trails accommodate limited two-way traffic and are generally 4 to 8 feet wide.
- Trails are designed and intended for use by pedestrians.

DOJ Assessment Factors:

- (i) size, weight, dimensions, and speed of the device.
- (ii) the facility’s volume of pedestrian traffic.
- (iii) the facility’s design and operational characteristics.

OPDMDs Allowed/Restrictions:

- No wider than 32 inches to allow for safe passing of other OPDMDs, dogs on leash, and pedestrians.
- Length restriction: Must allow for safe passing and turning on trails.
- Speed—In no case can an OPDMD be operated greater than the speed of pedestrian traffic.

Class II Trails

ID #	Park	Description	Distance Miles
34	Family	West parking lot to 12th Street drainage	0.68
35	Great Bear	Valley Trail	0.51
36	Great Bear	West Valley Trail	0.16
37	Arrowhead	Quarry Pond Trail	0.58
38	Arrowhead	North Loop Trail	0.40
39	Arrowhead	South Loop Trail	0.75
40	Sertoma	Woodland Trail	1.10
41	Sertoma	Prairie Trail	0.60
42	Sertoma	Riparian Trail	0.30

Class III

- Trail surface is soil or turf.
- Trails are designed and intended for pedestrians (hikers), OR are designed primarily for use by bicyclists, but are also open to hikers.
- Trails do not accommodate two-way traffic and vary from a maximum width of 24 inches to a width of up to 48 inches.
- Trails may have limited to no shoulders, have grades in excess of 5 percent, and steep side slopes.
- Trails are routed through heavily wooded areas, areas with sensitive soils, or areas containing sensitive communities of native grasses and flowers.

OPDMDs Allowed/Restrictions:

- OPDMDs not allowed.

DOJ Assessment Factors:

- (i) size, weight, dimensions, and speed of the device.
- (ii) the facility's design and operational characteristics.
- (iii) whether legitimate safety requirements can be established to permit the safe operation of the OPDMD at the facility.
- (iv) the potential for serious harm to environmental, natural and cultural resources.

Class III Trails

ID #	Park	Description	Distance Miles
43	Legacy	West of north picnic shelter and return (loop trail)	0.31
44	Great Bear	West Pond Trail	0.21
45	Great Bear	Skyline Trail	0.40
46	Great Bear	American Plum Trail	0.10
47	Great Bear	Ironwood Ridge Trail	0.27
48	Great Bear	Shady Glen Trail	0.05
49	Great Bear	Overlook Trail	0.57
50	Great Bear	Gateway Trail	0.23
51	Great Bear	Cactus Hills Trail	0.95
52	Great Bear	Oak Canyon Trail	0.16
53	Great Bear	Miners' Trace Trail	0.14
54	Great Bear	Grand Meadow Trail	0.22
55	Great Bear	Northern Slope Trail	0.54
56	Arrowhead	Stairstep Quarry Trail	0.28

Appendix 7: Parks ADA Related Policies

57	Arrowhead	Quarry Rock Trail	0.33
58	Yankton Trail	East Minnesota parking lot west to main paved trail	0.27
59	Yankton Trail	Main paved trail east to Minnesota parking lot	0.44

Appendix 8: Sioux Falls Executive Orders and Policies Regarding Disability

Appendix 9: InterpreCorps, LLC and Communication Service for the Deaf Contracts

Appendix 10: 211 Help Line Contract

Appendix 11: Sample Web Accessibility Report

Appendix 12: Emergency Preparedness Efforts for those with Disabilities.

Emergency Preparedness Efforts for Special Needs Populations

Vision

In advance of an emergency, man-made or natural, special populations, agencies, and organizations in Sioux Falls will work together to support a system that provides accessible information and resources needed to protect, prevent, respond, and recover.

Programs/Preparedness Activities:

- Red Cross has identified 15 ADA accessible facilities to be used as possible shelter locations in Sioux Falls in the event causes a large number of persons to be evacuated from their homes.
- City/County Unified Command Group (city, county, state, federal government, hospitals, volunteer agencies, utility providers, etc.) meets every other month to coordinate disaster response activities, training, exercises and resources. City ADA Coordinator is a part of this group.
- Sioux Falls Healthcare Coalition (SF Department of Health, Avera McKennan, Avera Heart Hospital, Children's Care, Sanford, Sioux Falls Surgical and Veteran's Administration) lead preparedness efforts for sustained medical care for special needs populations through case management and outreach services as well as through home health programs.
- Regional Response Planning includes:
 - Planning partners include hospitals, clinics, long term care providers, mental health care providers, community health centers, and public health
 - Regional support to respond to a mass casualty incident results in 500 casualties
 - Identified individuals, community based organizations and other agencies that support at risk/special needs populations
 - developed preparedness educational materials/toolkits to assist organizations and the special needs populations they serving preparedness efforts
 - providing outreach education/presentations to special needs populations providers
 - Supplies shelter/response trailers to support the housing of 200 people (mobile medical assets)

Appendix 12: Emergency Preparedness Efforts for those with Disabilities

- Acquired an Ambu-Bus conversion kit to allow transportation of limited mobility populations
 - Partnered with SDSU Education Extension Services to develop a Disaster Planning and Preparedness for Special Needs Populations Model
- Helpline Center 211 – City of Sioux Falls contracts with the Helpline Center to operate 24-hour call center to provide information to citizens on assistance/resources available to them following a disaster in the community.
- Call Notification Systems:
 - NIXLE – Sioux Falls Police
 - Sioux Falls Connect-Ed
 - City of Sioux Falls IVR – Public Works
- SFVOAD (Sioux Falls Volunteer Organizations Active in Disaster) – group of volunteer organizations that work with the City during time of emergency or disaster to provide assistance to victims, coordinate volunteers and overall community response and recovery efforts.
- The Sioux Falls Health Department and Falls Community Health has partnered with Lutheran Social Services to provide a Health and Safety orientation that is language appropriate to all new arriving refugees.
- The City of Sioux Falls, through Executive Order, has established provisions to provide broadcasting in languages other than English when public safety, health or emergency services responses require it.
- The City of Sioux Falls provides translation services through the use of Language Line and maintains contracts with local translator services for “in person” translation services.
- Development of emergency planning maps that identify group homes, assisted living centers, residential living centers, nursing homes, incarcerated and daycare centers.
- City worked with CSD, the South Dakota Association of the Deaf and a private vendor to make specialized NOAA weather radios available to deaf and hard of hearing community members at a reduced cost. CSD has partnered with the City to serve as liaison to relay emergency information to the deaf and hard of hearing community through text message and email.
- City of Sioux Falls hosted *FEMA Evacuation and Re-Entry Planning* course in May, 2006.

- Mass Prophylaxis Response Plans:
 - Include use of travel teams to reach populations that may not present to community mass dispensing sites due to barriers such as language and transportation;
 - Incorporate signage and education materials in several languages;
 - Have established a “greeter” position for all dispensing sites to help identify and meet the needs of special populations as they enter a dispensing site.
- The City of Sioux Falls maintains a contact list of agencies that can help provide outreach to populations that rely on non-medical assistance to maintain independent living (ex: Meals on Wheels providers, Comfort Keepers)

Response History

- 2009 H1N1 Immunizations - City immunized 30,000 persons in 2009 as part of nation-wide H1N1 flu immunization effort. Special efforts were made to ensure persons with disabilities had access to community clinics. In addition, the Sioux Falls Health Department worked with schools, group homes, nursing homes and other special populations to provide immunizations.
- 2010 Flood response planning – the Flood Incident Command Team worked with local healthcare providers, Public Safety and the Red Cross to identify homebound citizens that lived in the potentially affected area to be prepared to provide assistance in evacuations if the river levels overtopped the city’s levee system.
- In 2011 the community held Citywide functional and tabletop exercises in which tornado-based scenario required the evacuation of all residents and staff of Children’s Care Hospital and School. In addition to testing communications and coordination between the facility and the City, patient tracking was tested and city wide disaster support Memorandums of Understanding between healthcare facilities were exercised. Corrective actions from this exercise have strengthened the Sioux Falls Healthcare Coalitions ability to serve this special needs population during the time of a disaster.

Preparedness Messages for the Public

- Although each situation is unique, anybody can be better prepared if they plan carefully, put the emergency procedures in place, and reviews and practices for all kinds of emergencies.

Appendix 12: Emergency Preparedness Efforts for those with Disabilities

- Emergency Management expects all residents to be self-sufficient for 72 hours following an emergency or disaster:
 - Disaster Supply Kit
 - Water/Food/Medications/Essential Items
 - Family Emergency Plan/Communications Plan

Appendix 13: Emergency Planning Maps Regarding Disability

Appendix 14: Emergency Planning: *Region 3 At Risk Populations: Community Based Organizations*

Appendix 15: Sioux Falls Animal Emergency Response Plan

Appendix 16: Sioux Falls Police Department Policies Regarding Disability

Appendix 17: Documents related to Crisis Intervention Teams

Appendix 18: Sioux Falls Health Department—Falls Community Health Standard Operating Policy/Procedure for ADA: Providing Care to Individuals with Disabilities



**Sioux Falls Health Department—Falls Community Health
Standard Operating Policy/Procedure for
ADA: Providing Care to Individuals with Disabilities**

1.0 Purpose

- 1.1 To provide access to medical and dental care to adults and children with disabilities by complying with The Americans with Disabilities Act of 1990 (ADA) law that prohibits discrimination against individuals with disabilities.

2.0 Revision History

Date	Modification
2.1 7/15/2014	Origination
2.2 1/26/2015	Revised
2.3 05/29/2018	Reviewed

3.0 Persons Affected

- 3.1 Health Department staff working at Falls Community Health.
- 3.2 All providers that provide care at Falls Community Health.
- 3.3 All individuals that receive care at Falls Community Health.

4.0 Policy

- 4.1 It is the policy of the Health Department to comply with Section 504 of the Rehabilitation Act of 1973 (Section 504) law that prohibits discrimination against

Appendix 18: Sioux Falls Health Department—Falls Community Health Standard Operating Policy/Procedure for ADA: Providing Care to Individuals with Disabilities

individuals with disabilities on the basis of their disability in programs or activities that receive federal financial assistance, including health programs and services.

5.0 Definition

- 5.1 ADA – Americans with Disabilities Act
- 5.2 TRS- Telecommunications relay service
- 5.3 TTY- Text telephone

6.0 Responsibilities

- 6.1 All staff will be responsible and knowledgeable regarding the ADA requirements and assist patients with the education and information of services provided.
- 6.2 Clinic management will be responsible to provide training/education to Health Department staff annually and to all new employees.

7.0 Procedure

- 7.1 If a patient uses a wheelchair and needs to be examined on the exam table, staff will use the two-person method to transfer the patient to the ADA compliant exam table, a gait belt or a transfer board in the medical clinic. Dental staff can utilize the two-person method to transfer or utilize the lift to transfer the patient safely to the dental chair.
- 7.2 To obtain a weight of a patient that uses a wheelchair, staff will utilize the wheelchair accessible scale to obtain accurate weights.
- 7.3 Once the patient has been transferred to the exam table or chair, staff should assist the patient to a comfortable position, and if the exam requires the patient to disrobe, assistance should be offered by the staff. Patients will not be unattended by staff unless the patient says they do not require further assistance.
- 7.4 Radiologic exams will be carried out by radiology staff; assistance by additional staff to transfer the patient to the radiology table will be provided as needed.
- 7.5 If a patient uses a wheelchair, and requests transportation to the clinic, but is unable to access the Health Department vans, an alternative method to transport will be offered to the patient.
- 7.6 Service animals are defined as dogs and miniature horses that have been individually trained to do work or perform tasks for people with disabilities. Under the ADA, the Health Department must allow service animals to accompany patients with disabilities in all areas of the facility where the public is normally allowed to go.
- 7.7 For patients who are visually impaired or deaf-blind, auxiliary aids and services must be provided. This may include providing a qualified reader (staff member), information in large print, Braille, or a tactile interpreter. Clinical documents can be created within two business days to meet the request of the patient.
- 7.8 For patients that are hearing impaired, auxiliary aids and services must be provided. This may include providing a qualified note taker (staff member), a qualified sign language interpreter, tactile interpreter, TRS, or written materials.

Appendix 18: Sioux Falls Health Department—Falls Community Health Standard Operating Policy/Procedure for ADA: Providing Care to Individuals with Disabilities

- 7.9 For patients with a learning disability, a qualified reader may be provided for the clinic visit.

Public Health Director

Date

Appendix 19: About the Blanck Group, LLC

The Blanck Group, LLC, is a premier consulting firm with national and international clients specializing in disability law, policy, and practice. Formed by Dr. Peter Blanck, the firm draws together an expert team with experience in disability law, policy, and research, analysis, and litigation support and dispute resolution services. Dr. Blanck has been appointed a court officer by the U.S. Federal court to mediate complex disability litigation and has provided expert testimony in state and Federal courts as well as in mediation and arbitration. The Blanck Group's team of leading academics and researchers, lawyers, information technology professionals, and housing and access professionals, provide exemplary service and expertise to large and small organizations in the United States and abroad.

Peter Blanck, Ph.D., J.D., President, Blanck Group, LLC

Dr. Blanck is University Professor at Syracuse University, the highest faculty rank at the university. He is Chairman of the Burton Blatt Institute (BBI) at Syracuse University. Blanck has written on the Americans with Disabilities Act (ADA) and related laws and received grants to study disability law and policy. He is Chairman of the Global Universal Design Commission (GUDC), and he is President of Raising the Floor (RtF) USA. Blanck received a Juris Doctorate from Stanford University, where he was President of the *Stanford Law Review*, and a Ph.D. from Harvard University. Blanck is a former member of the President's Committee on Employment of People with Disabilities. Prior to teaching, Blanck practiced law at the Washington D.C. firm Covington & Burling and served as law clerk to the late Honorable Carl McGowan of the United States Court of Appeals for the D.C. Circuit.

Blanck's books include:

Disability Law and Policy (Foundation Press, 2020);

Supported Decision-Making: From Justice for Jenny to Justice for All! (with Martinis) (Something Else Solutions Press, 2019);

Supported Decision-Making: Theory, Research, and Practice to Enhance Self-Determination and Quality of Life (with Shogren, Wehmeyer, & Martinis) (Cambridge University Press, 2019);

Heavy Laden: Union Veterans, Psychological Illness, and Suicide (with Logue) (Cambridge University Press, 2018);

eQuality: The Struggle for Web Accessibility by Persons with Cognitive Disabilities (Cambridge University Press, 2014);

Disability Civil Rights Law and Policy (with Siegal, Waterstone, & Myhill) (West, 3d ed., 2014);

Genetic Discrimination: Transatlantic Perspectives on the Case for a European Level Legal Response (with dePaor & Quinn) (Routledge Press, 2014);

Legal Rights of Persons with Disabilities: An Analysis of Federal Law: Second Edition (with Goldstein & Myhill) (LRP Publications, 2013); and,

Race, Ethnicity and Disability (with Logue) (Cambridge University Press, 2010).

James Felakos, J.D., Consultant to Blanck Group

Mr. Felakos is known for his thirty years advancing the civil rights of individuals with disabilities at the local, state, and national levels. He is former Disability Rights Fellow for the American Civil Liberties Union; Staff Attorney and Interim Legal Director of the ACLU of Eastern Missouri; and Associate at Gibson, Dunn & Crutcher, LLP. Felakos received his Juris Doctorate from Columbia University, where he was a Harlan Fiske Stone Scholar.